



Global  
Green Growth  
Institute

## Deploying Electric Buses in the Kathmandu Valley

# A Pre-Feasibility Study

January 2018



Global Green Growth Institute  
January 2018

Global Green Growth Institute  
Jeongdong Building 19F  
21-15 Jeongdong-gil  
Jung-gu, Seoul 04518  
Republic of Korea

Recommended citation:

GGGI (2018). *Deploying Electric Buses in the Kathmandu Valley: A Pre-Feasibility Study*. Seoul: Global Green Growth Institute.

The Global Green Growth Institute does not make any warranty, either express or implied, or assumes any legal liability or responsibility for the accuracy, completeness, or any third party's use or the results of such use of any information, apparatus, product, or process disclosed of the information contained herein or represents that its use would not infringe privately owned rights. The views and opinions of the authors expressed herein do not necessarily state or reflect those of the Global Green Growth Institute.

All photos, including the cover photo, by Robic Upadhayay.

Deploying Electric Buses in the Kathmandu Valley

# A Pre-Feasibility Study

January 2018

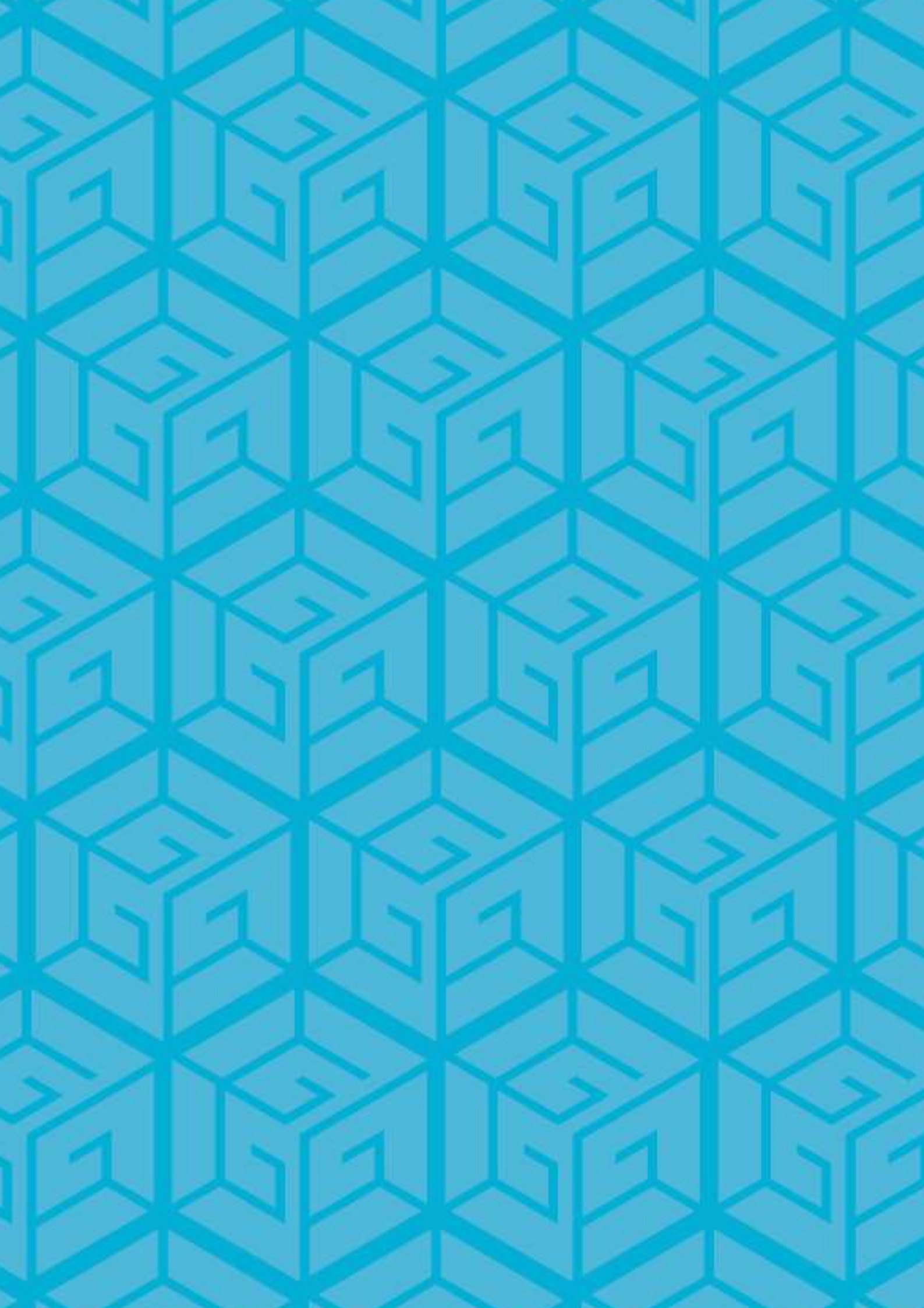

## Foreword

This pre-feasibility study was undertaken to support Sajha Yatayat's desire to transition to electric buses. Already Sajha Yatayat has an impressive track record as a progressive and pioneering transport service provider within the Kathmandu Valley, and more broadly within Nepal. By starting the exciting exploration of moving towards electric mobility, Sajha Yatayat once again demonstrated its leadership in the sector.

We would like to thank Sajha Yatayat for commissioning this study and partnering with the Global Green Growth Institute in the pursuit of electric mobility in Nepal. We would also like to thank the Government of Nepal, in particular the Ministry of Forests and Environment and the Ministry of Physical Infrastructure and Transport, for their collaboration in undertaking this study.

More generally, we hope that other public and private transport operators may find the results of this study useful. As the findings of the study indicate, there are numerous operational benefits which operators may expect and leverage to off-set the higher upfront costs of electric vehicles. Similarly, benefits are set to accrue to government, the economy and society and these are important considerations when exploring subsidies and other financial assistance to transport operators in switching to electric.

I look forward to joining other passengers and riding Nepal's first battery electric bus in due course!



Vikram Basyal  
Country Representative Nepal  
Global Green Growth Institute

## Abbreviations

ADB	Asian Development Bank
BAU	business as usual
BEV	battery electric vehicle
BEST	Brihanmumbai Electricity Supply and Transport
BMS	battery management system
BPKM	billion passenger kilometers
BYD	Build Your Dreams
CO <sub>2</sub>	carbon dioxide
COP21	21 <sup>st</sup> Conference of Parties
dB	decibels
DoC	Department of Customs
DoD	depth of discharge
DoE	Department of Environment
DoED	Department of Electricity Development
DoTM	Department of Transport Management
EPI	Environmental Protection Index
EV	electric vehicle
EVAN	Electric Vehicle Association of Nepal
EVC	Electric Vehicle Charging
EVI	Electric Vehicles Initiative
EVSE	electric vehicle supply equipment
FAME	Faster Adoption and Manufacturing of Electric Vehicles
FLA	flooded lead acid
GBP	Great British pound
GDP	gross domestic product
GGGI	Global Green Growth Institute
GHG	greenhouse gas
HEV	hybrid electric vehicle
ICE	internal combustion engines
ICEV	internal combustion engine vehicles
ICIMOD	International Centre for Integrated Mountain Development
IPCC	Intergovernmental Panel on Climate Change
kWh	kilowatt hours
LIB	lithium-ion battery

MoPE	Ministry of Forests and Environment
MoPIT	Ministry of Physical Infrastructure and Transport
MoUD	Ministry of Urban Development
MW	megawatts
NAAQS	National Ambient Air Quality Standards
NEA	Nepal Electricity Authority
NDC	Nationally Determined Contribution
Ni–Cd	nickel–cadmium
Ni–MH	nickel–metal hydride
Ni–Zn	nickel–zinc
NRB	Nepal Rastra Bank
NSTS	National Sustainable Transport Strategy
NYCT	New York City Transit
OBD	on-board diagnostics
OCV	open-circuit voltage
PHEV	plug-in hybrid electric vehicle
p-HEV	parallel hybrid electric vehicle
PM	particulate matter
PM-DC	permanent magnet-based motors
PV	photovoltaic
ROI	return on investment
SAE	Society for Automotive Engineers
SCM	Smart City Mission
SLA	sealed lead acid
SMG	Seoul Metropolitan Government
SoC	state of charge
TCO	total cost of ownership
TfL	Transport for London
TOD	transit-oriented development
UNFCCC	United Nations Framework Convention for Climate Change
UNCRD	United Nations Centre for Regional Development
USD	United States dollar
WB	World Bank
WHO	World Health Organization

# Contents

<b>Executive Summary</b>	<b>1</b>
Overview	1
Electric Vehicle Technology and its Benefits	1
Policy and Regulation Linked to Electric Mobility in Nepal	2
Sajha Yatayat’s Operations and Emissions Reduction Potential	2
Total Cost of Ownership Analysis of Deploying Diesel versus Electric Buses	2
Analysis of Local Manufacturing of Electric Buses	3
Transformative Potential of the Electric Bus Pilot Initiative	3
<b>Chapter 1. Introduction</b>	<b>5</b>
1.1 Growth of the Transport Sector in Nepal	5
1.2 Environmental Impacts of Growing Transport Sector	7
1.3 Government of Nepal and the Global Green Growth Institute	9
1.4 Deploying Electric Buses in Kathmandu	9
<b>Chapter 2. Electric Vehicle Technology</b>	<b>11</b>
2.1 Introduction	11
2.2 What is a Battery Electric Vehicle?	11
2.3 Major Components of BEV	11
2.3 Comparison of Diesel, Hybrid Electric and Full Electric Buses	18
<b>Chapter 3. Benefits and Challenges of Battery Electric Vehicles</b>	<b>21</b>
3.1 Introduction	21
3.1 Technology	21
3.2 Environment	22
3.3 Socio-Economic	23
<b>Chapter 4. Regulatory Landscape</b>	<b>25</b>
4.1 Introduction	25
4.2 Summary of Policies and Regulation	25
<b>Chapter 5. Route and Vehicle Analysis</b>	<b>29</b>
5.1 Introduction	29
5.2 Local Conditions in Kathmandu and Advantages for Electric Buses	29
5.3 Sajha Yatayat’s Fleet and Operations	30



5.4 Proposed Route for Electric Bus	33
5.5 Proposed Vehicle Options	35
5.6 Engagement with Bus Manufacturers	38
<b>Chapter 6. Greenhouse Gas Emissions Analysis</b>	<b>39</b>
6.1 Introduction	39
6.2 Assumptions and Data	39
6.3 Greenhouse Gas Emissions Results	40
<b>Chapter 7. Total Cost of Ownership Analysis</b>	<b>41</b>
7.1 Introduction	41
7.2 Data and Assumptions	41
7.3 Lifetime Costs	42
7.4 Economic, Social and Environmental Costs	44
7.5 Summary of Total Lifetime Cost Analysis	45
<b>Chapter 8. Options for Local Manufacturing</b>	<b>49</b>
8.1 Introduction	49
8.2 Review of Electric Vehicle Manufacturing in Nepal	49
8.3 Estimated Demand for Electric Buses	50
8.4 Estimated Local Manufacturing Process and Requirements	51
8.5 Direct Benefits of Local Manufacturing	53
8.6 Action for Local Manufacturing	53
<b>Chapter 9. Summary of Findings and Recommendations</b>	<b>55</b>
9.1 Electric Buses are Viable	55
9.2 Summary of Key Findings	55
9.3 Recommendations and Next Steps	56
<b>References</b>	<b>58</b>
<b>Annex 1 – Case Study Cities</b>	<b>62</b>
A. Electric Bus Initiative in the State of Karnataka	62
B. Electric Bus Initiative in the State of Himachal Pradesh	63
<b>Annex 2 – Summary of Vendors</b>	<b>64</b>
Introduction	64
Ashok Leyland, India	64
BYD (Build Your Dreams) Auto, China	65



ମହାନଗର ପାଲିକା

ମହାନଗର ପାଲିକା

ମହାନଗର ପାଲିକା

## Executive Summary

### Overview

Since 1990, the number of vehicles on Nepal's roads has risen by 14 % annually, driven by urbanization and rising incomes.<sup>1</sup> As a result, road transport is now the predominant form of transport in the country, accounting for some 80% of all trips.<sup>2</sup> The majority of this transport is private, with the overall share of public transport vehicles registered falling from 11% in 1990, to just 3% in 2015.<sup>3</sup> This has led to a corresponding increase in greenhouse gas emissions from the transport sector. In 1995, annual greenhouse gas emissions from the sector totaled 716 kilotons. This had risen to 3,170 kilotons by 2013. Similarly, there has been a substantial increase in particulate matter pollution, particularly in Nepal's metropolitan cities. Particulate matter (PM2.5), which includes dust from construction and other sources, as well as carbon particles released from the burning of fossil fuels and operation of vehicles, has risen in Kathmandu to an average annual 30.40 µg/m<sup>3</sup>. This is three times higher than the standard prescribed by the World Health Organization. Approximately 9,000 premature deaths occur annually in Nepal as a result of ambient air pollution.<sup>4</sup>

Working under the overall direction of the Ministry of Population and Environment, and in partnership with the Ministry of Physical Infrastructure and Transport, the Global Green Growth Institute (GGGI) launched the joint *Electric Mobility Program* to support a transition towards clean and sustainable transportation in Nepal. Under the program, which aims to boost the adoption of electric vehicles in Nepal, GGGI is also partnering with Sajha

Yatayat, Kathmandu's largest public bus operator, to seek opportunities to deploy electric buses in Sajha Yatayat's fleet. This pre-feasibility study reports on the results of an extensive analysis undertaken by GGGI, in consultation with Sajha Yatayat, the Department of Roads, the Department of Transport Management, the Kathmandu Municipal Corporation, and the Asian Development Bank. It draws on data provided by Sajha Yatayat, as well as a range of secondary sources.

### Electric Vehicle Technology and its Benefits

Technology for electric vehicles is improving, and production systems are maturing, reducing the per unit cost. Four components that are needed for efficient operation of an electric vehicle are a traction source, an energy source (battery), a battery management system and a charging facility. Within these four components, numerous options exist.

The battery size and type are critical. There are two types of batteries predominantly used in electric vehicles, namely, nickel-based aqueous batteries and lithium-ion batteries. Due to their high voltage, reliable discharge and good lifecycle, lithium-ion batteries are currently the most widely used battery system for electric buses. For a battery to perform at its optimum level, its operating windows of temperature, voltage, and structural changes should be considered.

---

<sup>1</sup> Department of Transport Management.

<sup>2</sup> ADB. 2016. Transport Sector Assessment: Country Partnership Strategy.

<sup>3</sup> Department of Transport Management.

<sup>4</sup> World Health Organization. 2016. Ambient air pollution: A global assessment of exposure and burden of disease. Retrieved from <http://apps.who.int/iris/bitstream/10665/250141/1/9789241511353-eng.pdf>

Electric vehicles bring a range of benefits. These include reduced greenhouse gas emissions, reduced air and noise pollution, reduced fuel consumption, increased energy security, increased road safety and employment opportunities. For example, at low speeds, the switch from diesel buses to electric buses can cause noise levels to fall by more than 20%, which translates to improved health and productivity. In addition, electric buses typically enjoy 50% lower maintenance costs, demonstrate higher capacity to provide greater torque at slow speeds and maintain high performance at low temperatures. These are all favorable given Nepal's context. In this regard, Nepal can also stand to benefit from adopting electric buses.

## Policy and Regulation Linked to Electric Mobility in Nepal

A number of policies, and increasing regulatory refinement, facilitate the adoption of electric vehicles in Nepal. The government has put in place a robust policy framework to support sustainable and electric transport, through the adoption of the National Transport Policy (2001) and Environment Friendly Transport Policy (2015). This latter policy sets specific targets for electric vehicle adoption. More broadly, Nepal's adoption of the Sustainable Development Goals, and the submission of its Nationally Determined Contribution (NDC) to the United Nations Framework Convention for Climate Change (UNFCCC) have further cemented its overall policy shift towards electric mobility.

In addition, the Nepal Rastra Bank and the Ministry of Finance are consistently improving the lending regulations to support electric vehicle consumption and including through significantly reduced import tax and other duties on electric vehicles, especially for public sector or transport usage.

## Sajha Yatayat's Operations and Emissions Reduction Potential

Sajha Yatayat is the principal organized bus cooperative in Nepal, and the largest full-size bus operator in Kathmandu Valley. It has a current fleet of 46 full size buses, expected to rise to 58 in 2018. These buses operate across six routes, travelling more than 6000 kilometers daily and catering to an average daily ridership of 18,498 passengers. Five of the six routes cater to passengers inside Kathmandu Valley and the remaining route caters to passengers traveling from Kathmandu to Baglung and back (600 km return trip).

Of the current 46 buses, 16 are manufactured by Tata Motors and 30 by Ashok Leyland, both major Indian automobile manufacturers. The Lagankhel-Budanilkantha route, a major 17-kilometer route that travels across the main north-south trunk route in the Kathmandu metropolitan region, has been identified as the most attractive option for deployment of electric buses for a number of reasons. These include road quality and gradient, length of route, passenger demand on route, visibility and promotional capacity of route, and capacity of terminus stations to hold charging facilities. The three electric bus models are proposed as viable for this route, namely BYD's K9 and K7 buses, and the Ashok Leyland Circuit bus.

In terms of greenhouse gas emissions reduction potential, if all buses within the projected 58-vehicle fleet of 2018 were to switch to electric, a reduction of 2,537 tons of CO<sub>2e</sub> per year would be possible. This is based on a weighted average fuel economy of 2.8 liters per bus, over a total annual distance of 2.5 million kilometers.

In 2017, Nepal imported around 30% of its electricity from India. Since the electricity being imported is predominantly generated from coal-based power plants, any end-use technology, including electric buses, using this electricity will effectively be contributing to global emissions. However, Nepal has targeted to increase its hydropower capacity to 10,000 MW by 2025. Gradually, as supply in the country increases, import from India will decrease. In the long-run, since more than 95% of electricity generated in Nepal is expected to come from hydropower, it can be safely assumed that electric vehicles will have no greenhouse gas emissions. This analysis does not consider upstream or downstream emissions – such as for the production of the buses themselves.

## Total Cost of Ownership Analysis of Deploying Diesel versus Electric Buses

To be operationally feasible, the deployment of electric buses needs to make financial sense. With this in mind, a total cost of ownership analysis was undertaken comparing the identified electric bus options with the current diesel bus operating on the Lagankhel-Budanilkantha route.

Of the three bus alternatives, the analysis found that the diesel bus was the most expensive over the lifetime of the vehicle, due to higher operational and maintenance cost, and significant social (health- and productivity-related costs due to air and noise pollution), environmental and

economic costs. Among the electric buses, the Ashok Leyland Circuit bus was the costliest option – indeed costlier than the current diesel model. Both the BYD buses are cheaper than diesel. The BYD K9 bus is 24% cheaper than diesel and the BYD K7 is 39% cheaper. See Table 1 below for a breakdown of these costs projected over the life of the bus (10 years).

## Analysis of Local Manufacturing of Electric Buses

Nonetheless, acquisition costs of electric buses are significantly higher, and this presents an initial hurdle, even if total lifetime costs of electric buses are less than those of diesel. One way to address this higher acquisition cost is through local assembly and manufacturing. In this regard, Nepal has two experiences with electric vehicle manufacturing to build off.

Following consultations with private sector, the investment required to setup a local manufacturing unit to assemble a 5-meter-long 20-seater midi-bus, was estimated at around NPR 71.5 million (USD 695,525). This includes cost of land, cost of construction of manufacturing infrastructure and the cost of tools. The total cost of assembly of a single unit of vehicle will range from NPR 900,000 to 1.5 million (USD 8754-14,591) depending on the battery type being used. After all the different components of the vehicle have been

imported, the 20-seater bus can be assembled by around 22 staff members within a week. This presents an opportunity to supply the market with significantly cheaper buses than can be otherwise obtained through importing. Nonetheless, this initial analysis would require further in-depth study and greater, more detailed consultation with private sector operations to verify all associated costs.

## Transformative Potential of the Electric Bus Pilot Initiative

This electric bus pilot initiative has the potential to provide long-term strategic benefit to Nepal. Although socio-economic, operational and environmental benefits have been quantified in this study, the long-term transformative potential of the initiative has not been strategically valued.

This initiative will provide an opportunity for public and private operators to assess viability of electric buses in routes around Kathmandu and in Nepal more generally. It will also provide policy makers and institutional bodies with the knowledge to sharpen policy instruments that can aid in further strengthening fiscal measures and incentives to upscale adoption of EVs in Nepal. As the world is turning a new leaf by shifting towards electric mobility, an electric vehicle revolution in Nepal is imminent and this electric bus pilot initiative will provide the right platform to jumpstart this revolution. The value of this is immeasurable.

**Table 1. Summary of total cost of ownership of electric versus diesel bus (NPR)**

Cost component (NPR)	Bus models			
	Diesel (Viking)	Electric (K7)**	Electric (K9)**	Electric (Circuit)**
Acquisition cost***	3,198,345	23,104,100	30,618,500	42,738,500
Lifetime fuel cost	13,087,901	2,861,036	2,861,036	2,861,036
Lifetime maint. cost	6,576,587	3,288,293	3,288,293	3,288,293
Economic cost	10,393,303	-	-	-
Social cost	11,723,683	-	-	-
Environmental cost	3,338,927	-	-	-
<b>Total (NPR)</b>	<b>48,318,746</b>	<b>29,253,429</b>	<b>36,767,829</b>	<b>48,887,829</b>
<b>Total (USD)*</b>	<b>470,027</b>	<b>284,566</b>	<b>357,664</b>	<b>475,563</b>
<b>% cheaper than diesel</b>	<b>-</b>	<b>39%</b>	<b>24%</b>	<b>-1%</b>

Source: GGGI

\*1 USD = 102.8 NPR

\*\* '-' here denotes a negligible value

\*\*\* Acquisition cost is exclusive of VAT as the operator is eligible for a VAT refund after purchase of the electric bus



### 1.1 Growth of the Transport Sector in Nepal

Since 1990, the number of vehicles operating in Nepal has risen significantly. National vehicle registration numbers – a good indicator of national demand – demonstrate an annual average growth rate of 14% during 1990-2015, as shown in Figure 1 below.<sup>5</sup> Growth over more recent years, has been particularly high, driven by urbanization and rising incomes. As a result, road transport is now the predominant form of transport in the country, accounting for some 80% of all trips.

Much of this growth has occurred in the Kathmandu Valley, home to Nepal’s largest metropolitan region. Approximately 24,000 vehicles were registered in Kathmandu Valley in 2000. This number had risen to over 67,000 vehicles by 2016 – a threefold increase.<sup>6</sup> Vehicles registered in the Kathmandu Valley now comprise some 66% of total registered vehicles in Nepal. Of the total registered vehicles in the Valley, more than 90% are for personal use.<sup>7</sup>

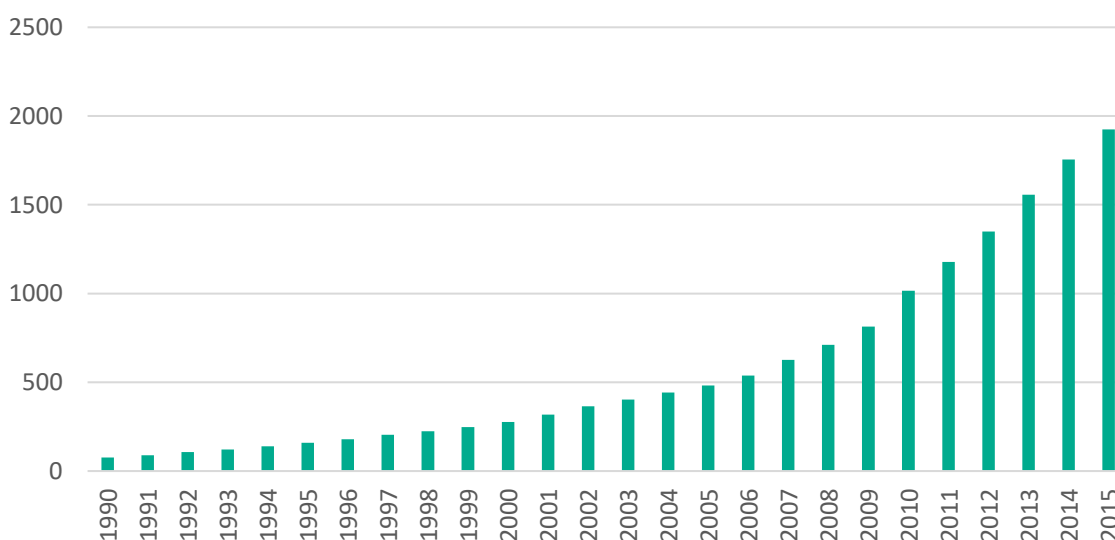

Source: Department of Transport Management, 2015

**Figure 1.1. Total cumulative registered vehicles in Nepal (thousand)**

<sup>5</sup> Ministry of Urban Development. 2015. National Urban Development Strategy 2015, Nepal. Urban Development and Physical Planning Division. Ministry of Urban Development (MoUD). Government of Nepal (GoN).

<sup>6</sup> Bajracharya and Bhattarai. 2016. 'Road Transportation Energy Demand and Environmental Emission: A Case of Kathmandu Valley' in *Hydro Nepal*, no. 18, January 2016 p. 30-40.

<sup>7</sup>*Ibid.*

Average annual growth rates of 11% for personal cars, and of 12% for two-wheelers (motorcycles) was recorded during 1991-2014.<sup>8</sup> Indeed, nationally, two-wheelers dominate passenger transport. These increases are exerting tremendous pressure on the Government of Nepal to introduce policies to manage emissions from the transport sector, as well as administer proper traffic practices. It's worth noting that these growth rates are based on cumulative datasets maintained by the national Department of Transport Management. However, each year, a large number of vehicles are scrapped due to age, and this rate of scrapping is unknown. As such, while

estimates exist, the total fleet of vehicles in the country is uncertain.

While much of the growth in vehicle registration numbers is the result of acquisition for personal usage, the number of public transport vehicles has also risen. In 1990, there were around 4000 buses in Nepal, rising to more than 35,000 by 2015.<sup>9</sup> Although the number of public transport vehicles, especially bus, minibus, microbus and tempos, in the transport sector of the country has increased in absolute terms, its share has decreased from 11% in 1990 to 3% in 2015, as shown in Figure 1.2.

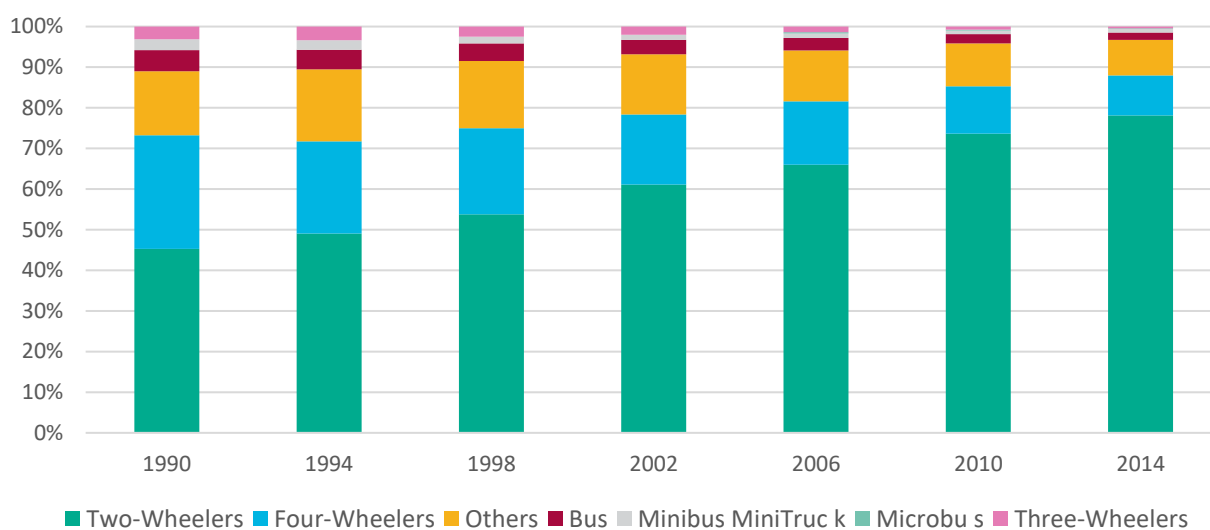

Source: Department of Transport Management, 2015<sup>10</sup>

**Figure 1.2. Modal distribution of passenger transport during 1990-2014.**

**Table 1.1. Origin of imported vehicles in Nepal (% of total)**

Country	Percent
India	89.0
Japan	4.5
Nepal	2.4
South Korea	1.3
China	1.2
Germany	0.6
Indonesia	0.5
Other	0.6
<b>Total</b>	<b>100</b>

Source: Central Bureau of Statistics 2014<sup>11</sup>

<sup>8</sup> United Nations Centre for Regional Development. 2015. National Sustainable Transport Strategy (NSTS) for Nepal (2015-2040). Ninth Regional Environmentally Sustainable Transport (EST) Forum in Asia, 2015. Ministry of Physical Infrastructure and Transport (MoPIT), Nepal. Ministry of Environment (MoE), Japan. United Nations Economic and Social Commission for Asia and the Pacific (UNESCAP).

<sup>9</sup> UNCRD. *Ibid.*

<sup>10</sup> Department of Transport Management. *Ibid.*

<sup>11</sup> Central Bureau of Statistics. 2014. Nepal Public Land Transport Survey 2013. National Planning Commission Secretariat.



Within this total pool of vehicles, a small but growing share are electric. There are some 714 electric three-wheelers (safa tempos) on the streets of Kathmandu, offering public transport services (see Chapter 8 for more information). In addition, a growing range of electric car manufacturers, including Kia, Mahindra and BYD are importing electric cars for private consumption. Total estimates for the number of electric cars in Nepal vary, but tend to range between 300 - 500 units at July 2017. Currently, around 300 Mahindra Reva and 4 BYD E6 have been sold in the market. In addition, efforts to introduce electric rickshaws and electric two-wheelers have also met with some success, though final vehicle numbers remain low.

Essentially, all conventional fossil fuel and electric vehicles in Nepal are imported, with only 3% being produced locally. Of the 97% imported, the majority come from India (89%), followed by Japan (4.5%) (see Table 1.1.).

Total taxes levied on imported fossil fuel vehicles are extremely high, amounting to 238%. Taxes, however, on electric vehicles are significantly reduced (see Chapter 4 for more information).

## 1.2 Environmental Impacts of Growing Transport Sector

The rising numbers of vehicles in Nepal, exacerbated by insufficient planning and management, is leading to a range of environmental challenges, including air and noise pollution, as well as challenges such as heightened congestion on metropolitan roads. A report by the Government of Nepal and United Nations Center for Regional Development on National Sustainable Transport Strategy (NSTS) for Nepal, released in 2015, emphasizes that this rapid growth in motorization threatens energy

security, can undermine social equity, increases greenhouse gas emissions and other air pollutants, and negatively impact ecosystem.<sup>12</sup>

In particular, emissions from the transport sector are on the rise. Consumption of petroleum products in the transport sector has increased by an average annual growth rate of 9%. However, growth in CO<sub>2</sub> emissions from the sector has been higher – at an annual average rate of 11% during 1994-2013 (see Figure 1.3).

In addition to greenhouse gas emissions, other air pollutants are also rising, particularly in Nepali cities. In Kathmandu Valley, annual average exposure to fine particulate matter (PM<sub>2.5</sub>) as per the Environmental Performance Index (EPI) was 30.40 µg/m<sup>3</sup> in 2014, three times higher than the WHO standard of 10 µg/m<sup>3</sup> (EPI 2016)<sup>13</sup>, though less than the maximum concentration of 50 µg/m<sup>3</sup> set in the National Ambient Air Quality Standard of Nepal.<sup>14</sup>

In 2016, only the rapidly developing economies of China, India and Bangladesh performed worse than Nepal in this indicator (ibid.). In 2016, the annual average concentration of PM 2.5 in Kathmandu Valley was nearly five times higher than the WHO standard<sup>15</sup>, and more than four times higher than the average across the rest of the country<sup>16</sup>. The concentration has almost doubled within the past three decades.

In addition to PM<sub>2.5</sub>, PM<sub>10</sub> is a growing problem. 63% of the total PM<sub>10</sub> in Kathmandu Valley has been estimated to come from vehicles and road dust<sup>17</sup>. During morning rush hours, it has been observed that PM<sub>10</sub> emissions in certain locations in Kathmandu, for example in Putalisadak, Sohrakutte and Maharajgunj is three to seven times higher than the NAAQS standard.

---

<sup>12</sup> UNCRD, 2015

<sup>13</sup> EPI. 2016. Environmental Performance Index 2016. Yale University. [http://epi.yale.edu/sites/default/files/2016EPI\\_Full\\_Report\\_opt.pdf](http://epi.yale.edu/sites/default/files/2016EPI_Full_Report_opt.pdf)

<sup>14</sup> For an overview of the NAAQS, see <http://doenv.gov.np/files/download/Report%20on%20AQ%20Action%20Plan%202017.pdf>

<sup>15</sup> WHO. 2016. Ambient air pollution: A global assessment of exposure and burden of disease. World Health Organization.

<http://apps.who.int/iris/bitstream/10665/250141/1/9789241511353-eng.pdf?ua=1>

<sup>16</sup> World Bank. 2016b. The Cost of Air Pollution. Strengthening the Economic Case for Action.

<http://documents.worldbank.org/curated/en/781521473177013155/pdf/108141-REVISED-Cost-of-PollutionWebCORRECTEDfile.pdf>

<sup>17</sup> [http://www.cen.org.np/uploaded/AQ%20Status%20and%20Managment%20in%20KV\\_Maya%20Factsheet%202015.pdf](http://www.cen.org.np/uploaded/AQ%20Status%20and%20Managment%20in%20KV_Maya%20Factsheet%202015.pdf)

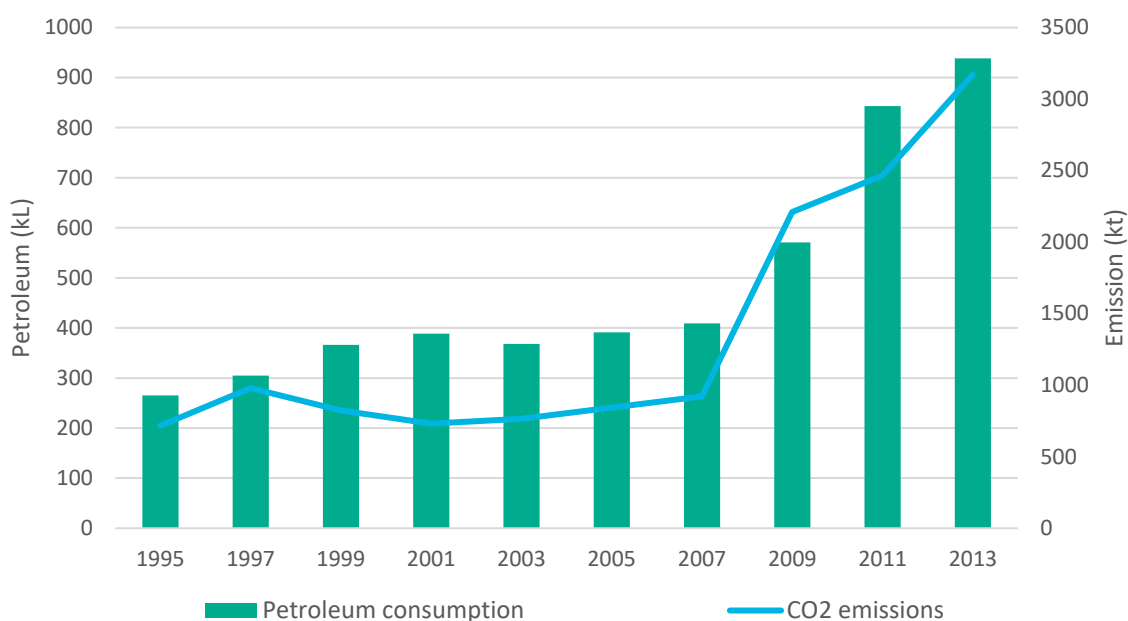

Source: World Bank, 2017<sup>18</sup>; Nepal Oil Corporation, 2016<sup>19</sup>

**Figure 1.3. Petroleum consumption and CO<sub>2</sub> emissions from the transport sector**

**Table 1.2. Standards versus levels of PM concentrations in Nepal**

PM Pollution Standards		Nepal NAAQS	WHO	Spring	Monsoon
		2012	2005	Kathmandu 2014	
PM <sub>10</sub>	Annual average	-	20 µg/m <sup>3</sup>		
	Daily average	120 µg/m <sup>3</sup>	50 µg/m <sup>3</sup>		
PM <sub>2.5</sub>	Annual average	-	10 µg/m <sup>3</sup>		
	Daily average	40 µg/m <sup>3</sup>	25 µg/m <sup>3</sup>	124.8 ± 55.9 µg/m <sup>3</sup>	45.1 ± 16.4 µg/m <sup>3</sup>

Source: Ministry of Science, Technology and Environment 2012<sup>20</sup>; Greenstone et al. 2015<sup>21</sup>; Shakya et al., 2017<sup>22</sup>

<sup>18</sup> World Bank. 2017. CO<sub>2</sub> emissions (kt). Carbon Dioxide Information Analysis Center, Environmental Sciences Division, Oak Ridge National Laboratory, Tennessee, United States. <https://data.worldbank.org/indicator/EN.ATM.CO2E.KT?locations=NP>

<sup>19</sup> Nepal Oil Corporation. 2016. Sales of Petroleum Products. <http://www.nepaloil.com.np/import-and-sales-22.html>

<sup>20</sup> Ministry of Science Technology and Environment. 2012. National Ambient Air Quality Standard.

<sup>21</sup> Greenstone, Michael, Janhavi Nilekani, Rohini Pande, Nicholas Ryan, Anant Sudarshan, and Anish Sugathan. 2015. "Lower Pollution, Longer Lives, Life Expectancy Gains If India Reduced Particulate Matter Pollution." *Economic & Political Weekly*.

<sup>22</sup> Shakya, K.M., Rupakheti, M., Shahi, A., Maskey, R., Pradhan, B., Pandey, A., Puppala, S., Lawrence, M., Peltier, R. 2017. Near-road sampling of PM<sub>2.5</sub>, BC, and fine-particle chemical components in Kathmandu Valley, Nepal. *Atmospheric Chemistry and Physics*; 17: 6503-6516.

In 2013, more than 22,000 deaths in Nepal were attributed to air pollution (ibid.). In that same year, air pollution-induced loss of welfare was recorded at 2.8 billion USD, equivalent to nearly 5% of the country's GDP (ibid.). This is equivalent to approximately 40% of the losses and damages caused by the 2015 earthquake, estimated at 7 billion USD<sup>23</sup>. It is, however, important to note that the economic losses due to air pollution occur annually. The projected increase of PM 2.5 will have substantial effect on the economy, i.e. healthcare cost will increase, lost working days will affect labor productivity, and crop yields will decline<sup>24</sup>.

### 1.3 Government of Nepal and the Global Green Growth Institute

In order to proactively manage and address these issues, the Government of Nepal has initiated a range of policy and regulatory action. These are outlined in Chapter 5. In particular, the Government of Nepal has prepared and submitted its Nationally Determined Contributions (NDCs) to the United Nations Framework Convention on Climate Change (UNFCCC), which includes important targets for electric mobility and air quality improvement and general reduction in GHG such as increasing the share of electric vehicles in the total vehicle fleet to 20% by 2020 from 2010 levels, reducing fossil fuel consumption in the transport sector by 50% in 2050 by promoting efficient transport services and reducing air pollution levels by 2025.

In addition to policy action, the Government of Nepal, through its Ministry of Population and Environment, has directed the Global Green Growth Institute to provide technical assistance in support of the implementation of a range of ambitious targets for sustainable, clean transportation... This partnership with the GGGI has led to the design and implementation of the joint GGGI-Government of Nepal *Electric Mobility Program*. There are three components of the EMP, namely:

- **Nationally Determined Contribution Action Plan for Electric Mobility** - In this component, GGGI aims to develop actions to accelerate implementation of targets specific to electric vehicles, outlined in Nepal's Nationally Determined Contribution. These actions will pertain specially to improving governance, mitigating greenhouse gas emissions, improving monitoring, reporting as well as verification and

increasing visibility to financing tools to increase the share of electric vehicles in the transport sector.

- **Pipeline of Bankable Projects** – This component is designed to introduce bankable project ideas concerning electric vehicles in the transport sector. The project design will be optimized according to availability of investment opportunities.
- **Electric Bus Pilot Initiative** – Through this component, GGGI and Sajha Yatayat, are aiming to introduce pilot electric buses in Sajha Yatayat's Lagankhel-Budanilkantha route. This initiative can be a potential model to public bus operators, including Sajha Yatayat, in proving viability of electric buses in Nepal.

These components are being implemented during 2017-2018.

### 1.4 Deploying Electric Buses in Kathmandu

In order to implement the Electric Bus Pilot Initiative, outlined above, GGGI has partnered with Sajha Yatayat, Nepal's largest publicly owned public bus operator. Under the partnership, Sajha Yatayat and GGGI, in close coordination with the Ministry of Physical Infrastructure and Transport, has sought to fully understand the feasibility of deploying electric buses as part of the existing Sajha Yatayat fleet.

Within this context, this pre-feasibility study was undertaken in order to:

- Understand how the current policies and strategies create an enabling environment for deployment of electric vehicles, specifically electric buses.
- Understand the long-term non-operational (social, economic and environment) costs of a diesel bus
- Identify the most viable route of Sajha Yatayat for deployment of electric buses;
- Understand greenhouse gas mitigation potential of electric buses in Sajha Yatayat's fleet.
- Analyze the financial viability of electric buses in Sajha Yatayat's Lagankhel-Budanilkantha route
- Compare operations and maintenance costs of diesel and electric buses.
- Explore the resource requirements and benefits of local manufacturing of electric buses.

<sup>23</sup> NPC. 2015b. Nepal earthquake 2015. Post Disaster Needs Assessment, Vol. A: Key Findings. National Planning Commission. <http://www.un.org.np/sites/default/files/PDNA-volume-B.pdf>

<sup>24</sup> OECD. 2016. The economic consequences of outdoor air pollution. Policy Highlights. Organisation for Economic Co-operation and Development. <https://www.oecd.org/environment/indicators-modelling-outlooks/Policy-Highlights-Economic-consequences-of-outdoor-air-pollution-web.pdf>

Primary data source for the analysis was Sajha Yatayat. Secondary level data was obtained from stakeholder consultations with the Ministry of Physical Infrastructure and Transport (MoPIT), Department of Environment (DoE), Nepal Electricity Authority (NEA), Department of Transport Management (DoTM), International Centre for Integrated Mountain Development (ICIMOD), Department of Customs (DoC), Electric Vehicle Association of Nepal (EVAN) as well as a literature review of published sources.

This study builds on GGGI's technical expertise deployed for the pre-feasibility study on *Deployment of Electric Buses in Himachal Pradesh*, along with the *Green Growth Strategy for Karnataka*, both undertaken by the GGGI team in India (see Annex 3 for detailed information of the Himachal Pradesh and Karnataka case studies). This work in Nepal is indebted to the work of colleagues in India and elsewhere within GGGI, and the technical precedent set by the work in Himachal Pradesh above all.

This report, which presents the findings and results of the prefeasibility study, is structured as follows:

- **Chapter 2: Electric Bus Technology** – This chapter provides a brief overview of the different components of an electric bus, including batteries, charging stations, etc.
- **Chapter 3: Benefits of Electric Vehicles** – Benefits of electric vehicles have been elaborated in this chapter.
- **Chapter 4: Regulatory Landscape** – Existing policies, strategies and fiscal instruments in

escalating deployment of electric vehicles have been identified in this chapter.

- **Chapter 5: Route and Vehicle Analysis** – This chapter explores the most viable route option of Sajha Yatayat, in which electric buses can potentially be deployed. In addition, route specific electrical bus specification has also been outlined in this chapter.
- **Chapter 6: Greenhouse Gas Emissions Analysis** – Greenhouse gas emissions of the projected fleet of Sajha Yatayat in 2018 is analyzed in this chapter.
- **Chapter 7: Financial Analysis** – This chapter compares the operational and non-operational costs of electric buses with that of diesel buses in order to justify financial viability of an electric bus on Sajha Yatayat's Lagankhel-Budanilkantha route.
- **Chapter 8: Options for Local Manufacturing** – Local electric bus manufacturing specifications and benefits have been introduced in this chapter. In addition, this chapter discusses the various strategies that need to be adopted in order to optimize electric vehicle assembly in Nepal.
- **Chapter 9: Summary of Vendors** – This chapter provides a brief summary of the two potential electric bus suppliers, Ashok Leyland and BYD.
- **Chapter 10: Conclusion** – This chapter presents summary of the key findings as well as recommendations.

### 2.1 Introduction

Conventional road transport vehicles are powered by burning fossil fuels, namely gasoline or diesel, in internal combustion engines (ICE) whereas pure electric vehicles (EVs) are powered by electricity and propelled by traction motors. The first patent for an electric motor was granted to Thomas Davenport in 1837. Since then electric motors have evolved significantly and are in use for propulsion in locomotives, surface and underwater vessels, inter-planetary vehicles, UAVs and road transport electric vehicles. EVs can get electric energy from on-board sources (e.g. battery, fuel cell, ultra-capacitor etc.), from electricity generator connected to ICE, and from off-vehicle energy sources such as overhead lines or underground wireless energy transfer systems. Vehicles with two energy sources, primarily ICE and battery, are called hybrid electric vehicles (HEV).

### 2.2 What is a Battery Electric Vehicle?

Battery electric vehicles (BEV), also known as fully electric vehicles, have an electric propulsion system, which consists of a battery and an electric motor connected to the driveshaft. Electricity from a source such as a chemical battery, ultra-capacitor or fuel cell, is used to energize the electric motor in an electric vehicle.

The traction motor is connected to a gear-train that transfers motor power to drive wheels. The motor is controlled electronically through a battery management system to generate the required torque and power for vehicle motion, maintain stable electric current, and optimize battery operation for battery life and safety.

There are two popular configurations for connecting motor power to wheels, namely a) connecting the motor to a differential and transferring power to both wheels from a single motor, as shown in Figure 2.1 having in-wheel motors to drive the vehicle, as shown in Figure 2.2.

There are competing technologies in electric vehicles for traction, energy storage and overall technology implementation. Currently, most commercially available electric vehicles use onboard chemical batteries as the source of electricity for operation.

### 2.3 Major Components of BEV

Battery electric vehicles use chemical battery as a source for electricity. Major components of a BEV that differ from a conventional internal combustion engine (ICE) are:

- Traction source – electric motor
- Energy source - battery
- Battery charging station
- Battery management system for safe and optimal use of batteries

Each of these three components will be explored in turn below.

#### 2.3.1 Traction Source

The ideal vehicle propulsion source provides constant power to the driveline throughout its operating range. Vehicles starting from rest require a high starting torque to overcome the inertia of rest. The vehicle overcomes resistance due to gradient, rolling and wind to achieve a steady drive speed.

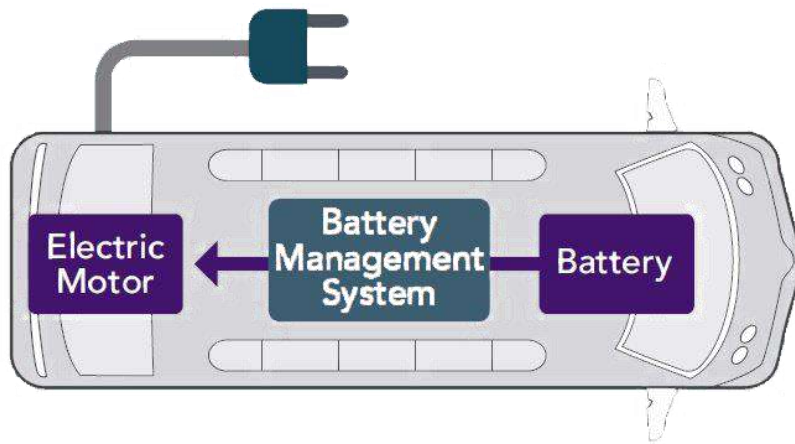

Source: GGGI, 2015<sup>25</sup>

**Figure 2.1. Electric vehicle with basic elements in front/rear configuration**

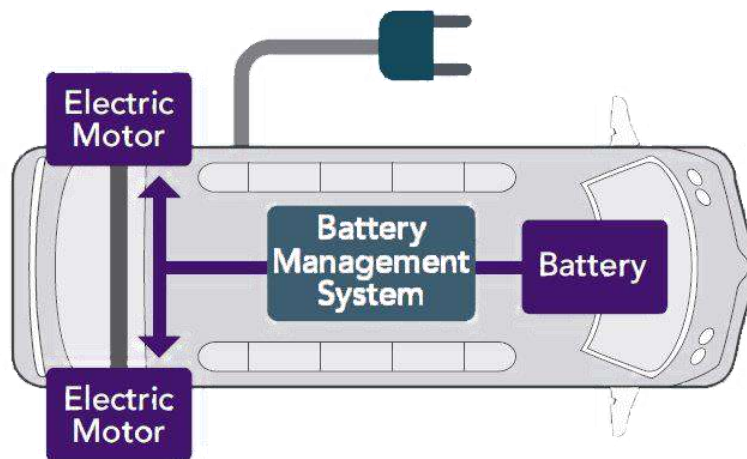

Source: GGGI, 2015<sup>26</sup>

**Figure 2.2 Electric vehicle with basic elements for an in-wheel mounted motor configuration**

<sup>25</sup> Global Green Growth Institute. 2015. Deployment of Electric Buses in Himachal Pradesh

<sup>26</sup> Ibid.

In Figure 2.3, variation of power output, torque output, and specific fuel consumption with respect to engine speed is plotted for an ICE. As can be inferred from this figure, the power output from an ICE increases with increasing engine speed, reaches a maximum and then drops very quickly. The torque from an ICE increases with engine speed, reaches a maximum value and then decreases with increasing engine speed.

In Figure 2.4, variation of power output and torque output with respect to engine speed is plotted for an electric motor. As can be inferred from this figure, the power output from an electric motor increases with increasing motor speed, reaches a maximum and remains constant after that. The speed at which it attains peak power is called the 'base speed' of the motor. An electric motor starts with the maximum torque which stays at that level for most of its operating range.

**Power Band:** The power band of an engine or electric motor refers to the range of operating speeds under which the engine or motor is able to operate efficiently. It is defined by the engine speed range from peak torque to peak power. ICEs have a large range of operating speeds but the power band is a much smaller range of engine speed. Conversely, electric motors produce constant torque for most of their operating speed.

An ICE has a lower operating efficiency in low gear than in high gear. Thus, on hilly terrain, ICE buses driving in low gear give poor fuel economy.

The torque speed characteristics of an ICE do not match the desired ideal characteristics of a propulsion system. As a result, a gear box is added. As plotted in Figure 3.3, a mechanical transmission with different gear ratios is employed to achieve desired tractive effort over the full range of vehicle speeds. For an electric motor, a single gear transmission allows for desired tractive effort over the full range of vehicle speeds.

A vehicle overcomes different types of external resistance to achieve motion. Such resistances include gradient, rolling, wind, and grade resistance, which is a function of the weight of the vehicle and the gradient of the road. For a given vehicle, grade resistance increases with an increase in gradient. The maximum gradient a vehicle can traverse at a speed is referred to as the vehicle's gradeability. Also, the maximum gradient a vehicle can traverse starting from a stop condition is referred to as the vehicle's stop-start gradeability. Rolling resistance is an experimentally determined value and is a property of the vehicle wheels and road condition. Wind resistance is dependent on vehicle velocity and vehicle body profile.

For a hilly area, vehicle wheels and road conditions remain similar and wind resistance is low at slow speeds. Grade resistance becomes the dominant resistance to motion of the vehicle. ICE and EV handle gradient differently – an electric motor can achieve the required tractive effort with a single gear reduction. Conversely, an ICE operates in low gear and at high engine speed to achieve the same level of tractive effort. An ICE operating at a lower gear ratio gives poor fuel efficiency whereas an EV can overcome similar gradients without much loss of efficiency.

Given the above review, a suitably sized electric motor in an electric vehicle can:

- Provide high torque at low speeds
- Effectively handle gradients and provide better fuel economy than ICE
- Match the performance of ICE vehicles on tractive effort parameters

### 2.3.2 Battery Technology

The source of energy in a battery EV is onboard battery packs which store energy as electrochemical potential. These battery packs are charged through dedicated electric charging stations. Different battery technologies have evolved over time as shown in Figure 3.4. Currently, lithium ion batteries are most suitable for EV applications due to the capacity of these batteries to provide high specific energy and high specific power.

Classes of rechargeable battery that have been used for EV applications are as follows:

- Nickel-based aqueous batteries – viable but unsuitable
- Lithium ion batteries – most viable option
- Lead acid batteries – unsuitable for electric bus

**Nickel-based aqueous battery** - These batteries are mainly nickel cadmium (Ni-Cd), nickel zinc (Ni-Zn) and nickel metal hydride (Ni-MH). The cathode in all these variants is nickel hydroxide, with potassium hydroxide as the electrolyte. The anode is different in each of the above systems, being either cadmium, zinc or a complex metal alloy (a mix of rare earths, nickel, zirconium and aluminum etc.) respectively. Although Ni-Cd were an upgrade from lead acid batteries, the Ni-Cd is being phased out world over due to the toxicity of cadmium. Of these variants, the Ni-MH battery performs better than the Ni-Cd battery in terms of higher specific energy, longer life, higher discharge rate, and greater environment friendliness. However, the Ni-MH battery shows poor performance when operating below freezing, has a low shelf life and has a high self-discharge rate when not in service. On the other hand, the Ni-Zn battery displays good performance in terms of cell voltage, charge storage capacity and high rate discharge capability but suffers from growth of dendrites on the zinc anode during cycling causing internal short circuits and material (storage capacity) loss over time.

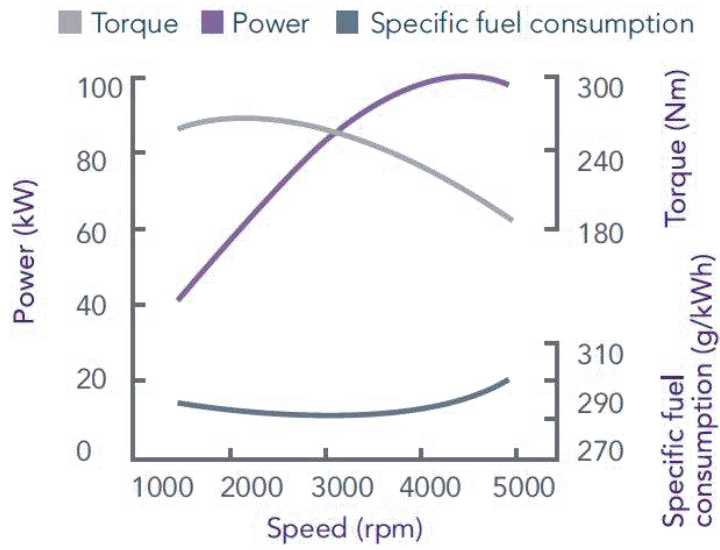

Source: Mehrdad et al.<sup>27</sup>

Figure 2.3 Typical characteristics of a conventional vehicle

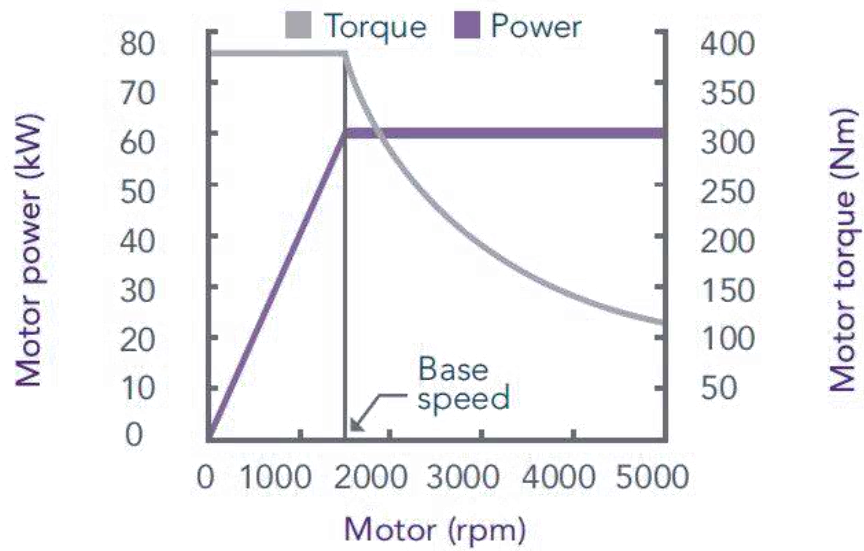

Source: Mehrdad et al.

Figure 2.4 Typical characteristics of an electric motor

<sup>27</sup> Mehrdad Ehsani et al., Modern electric, hybrid and fuel cell vehicles, fundamentals, theory and design.



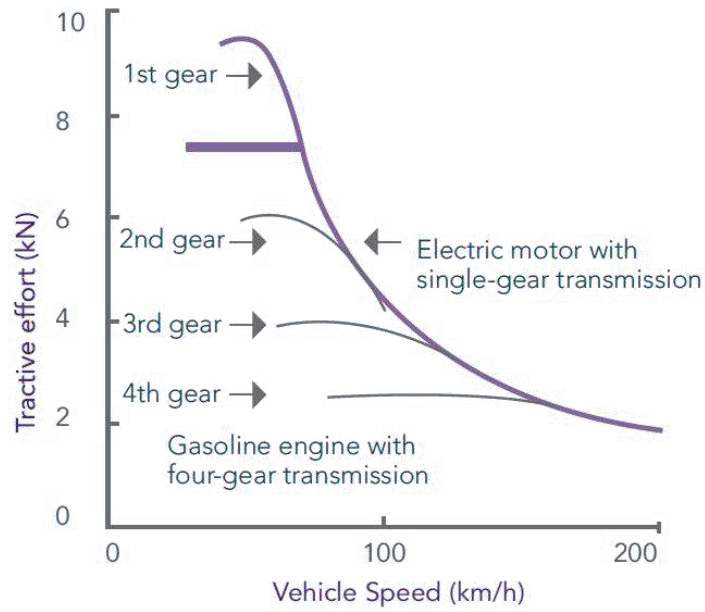

Source: Mehrdad et al.<sup>28</sup>

Figure 2.5 Tractive effort from manual 4-gear transmission conventional vehicle and 1-gear transmission electric motor

Source:

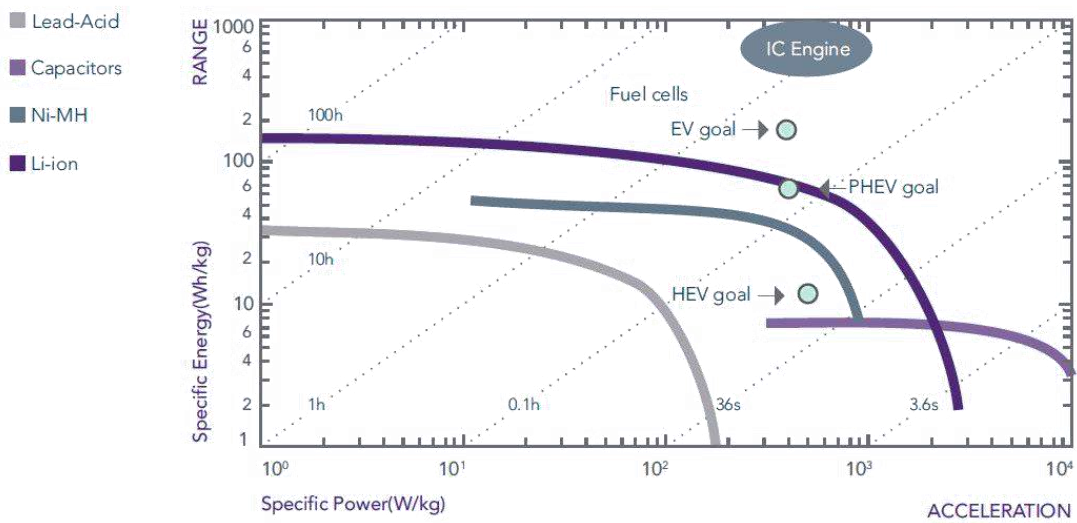

European Rare Earth Recycling Network, 2014<sup>29</sup>

Figure 2.6. Specific energy and specific power for different battery types

<sup>28</sup> Mehrdad Ehsani et al., Modern electric, hybrid and fuel cell vehicles, fundamentals, theory and design.

<sup>29</sup> European Rare Earth (Magnet) Recycling Network. 2014. Rare earths in energy storage and conversion (2014). <http://erean.eu/wordpress/2014/10/>

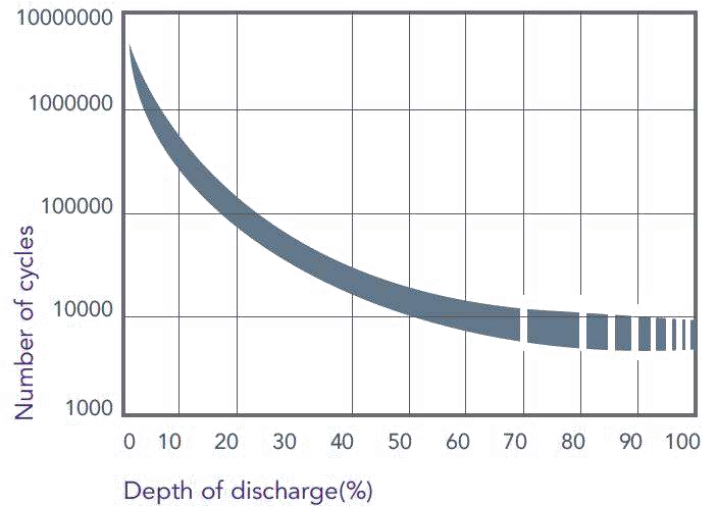

Source: Saft, 2014<sup>30</sup>

**Figure 2.7. Life of lithium ion battery measured against depth of discharge.**

### **Lithium ion battery**

The lithium ion battery displays high cell voltage, reliable high discharge rate, and good cycle-life. It has a cathode, which is a compound of lithium and transition metal oxides (or phosphates), an anode, which is mostly carbon-based, and electrolyte made up of organic solvents with lithium salts. Cell voltage is dependent upon the cathode chemistry, which can be increased using cathode materials with higher voltage.

There are newer high voltage candidate cathode materials but due to electrolyte stability issues beyond 4.8 V, the favorable chemistry of these cathodes remains under-exploited. Discovery of high-voltage-compatible electrolyte materials is crucial. However, new safer cathode chemistries have to be optimized as high inherent oxygen partial pressure in the popular oxide-based cathodes can result in explosions. This issue was highlighted in recent battery related fire incidents in Chevy Volt electric car and Dreamliner aircraft. At present, phosphate-based cathode chemistries (e.g. lithium iron phosphate cathode) are preferred over oxide-based alternatives due to higher safety features despite having lower operating voltage.

The high cost of cathodes is due to the presence of lithium. In many battery technologies, the anode is the less expensive component. The electrolyte is a mixture of organic solvents like ethylene carbonate or dimethyl carbonate, and contain dissolved salts of lithium (e.g.,

LiPF<sub>6</sub>). The major challenges of the lithium ion battery are lower safety and high cost.

Depth of discharge is a measure of the utilization of a battery against the maximum charge it can hold. As seen in Figure 2.7, an increase in the depth of discharge exponentially reduces the number of charge cycles a battery can serve. Even at 90 % depth of discharge a lithium ion battery can last for more than 3000 charge cycles, which is equivalent to nine years of active life (assuming vehicle operating for 333 days in a year on daily charge).

### **Lead acid batteries**

There are two types of Lead acid batteries: sealed lead-acid (SLA) and flooded lead-acid (FLA) batteries. The FLA batteries have been the most commonly used EV batteries as it has a long life (up to four years) and provides the least cost amp-hour among all the available batteries. Unlike the FLA, in the SLA, the electrolyte is held either in mats of glass fibers or in gel form. However, these are more resistant to damage from physical shocks than the FLAs. SLAs are maintenance free but once its electrolytes leak out, there is no way to fix it.

The FLAs survive in high temperature, whereas with the SLA batteries, high temperatures cause a loss in electrolyte that decreases efficiency of the batteries. However, one major drawback of the FLA batteries is that it produces hydrogen gas, which can be flammable in high concentrations. Thus, it should be kept in a protective box with a duct that can

<sup>30</sup> Saft. (2014). Lithium Battery Life; Solar photovoltaic (PV) - Energy Storage Systems (Ess). Saft. [http://www.saftbatteries.com/system/files\\_force/li\\_ion\\_battery\\_life\\_\\_TechnicalSheet\\_en\\_0514\\_Protected.pdf](http://www.saftbatteries.com/system/files_force/li_ion_battery_life__TechnicalSheet_en_0514_Protected.pdf)

release the hydrogen gas to the atmosphere (Home Power Inc., 2017).

Lead acid batteries are not suitable for electric bus operation due to following technology limitations:

- Low energy density
- Low charge cycles
- Environmental damage due to lead content

However, for smaller electric vehicles with low loads over small distances, lead acid batteries can be viable. In Kathmandu, sealed lead acid batteries are being used for three-wheeled EV, such as safa tempos and small electric rikshaws. Lead acid batteries also tend to be low cost.

### 2.3.3 Battery Charging Facilities

Infrastructure for battery charging is essential for a sustainable EV fleet. In order to charge, the batteries of plug-in EVs require a physical connection with electric vehicle supply equipment at the charging station.

There are two principal methods of charging batteries:

- **Conductive charging** - Conductive charging requires a physical connection between the EV and EVSE at the charging station. This technology has been historically the most popular option for accessing grid electricity for various charging applications. The automotive standard voltage plugs and sockets interface between the distribution lines and the on-board sockets. All battery systems currently use the conductive charging technology.
- **Inductive or contactless charging** - Major approaches to transfer energy to on-board batteries has been through direct electrical contact but innovators have experimented with wireless charging to remove the hassle of connecting high potential electric points. This is a relatively new technology that has emerged in recent years. Inductive charging uses an electromagnetic field to enable the exchange of energy between the EV and the charging station. In this method, no physical contact is needed between the energy source and the vehicle. Inductive charging works by using an induction coil placed within a charging station to create an electromagnetic field. A second induction coil, placed on the EV, takes power from the electromagnetic field and converts it into an electrical current that is used to charge the on-board battery. The advantages of such wireless charging systems include safety (no exposed conducting surfaces, hence no electric shock), no cable needs, high reliability, low maintenance (automatic, minimum intervention required),

reduced risk of theft and long product life due to less wear and tear.

The time taken to charge a battery is an important issue for the larger adoption of EVs and is a crucial factor in making decisions regarding charging methods as well as EV route selection. Charging time depends on the charging methodology and also on the battery type, storage capacity and size. Opting for a reduced charging time increases costs due to several associated factors like usage of more expensive battery variants that are made up of materials having higher charge storing capacity, and more efficient and sophisticated charging techniques. As a result, the method of charging should be decided by considering the application needs after doing a thorough techno-economic analysis. The advantages and disadvantages of different charging types are presented in Table 2.1 below.

### 2.3.4 Battery Management System

A battery functions optimally within certain operating windows of temperature, voltage, structural changes (during charge-discharge) and other parameters. In order to ensure optimal functionality, EV use a battery management systems (BMS).

A BMS contains sensors and controllers. Sensors measure operating parameters like temperature, current and voltage in the circuit to help manage the cells within the optimum windows – for lithium ion batteries, for example, optimal charging temperature is between 0 C to 45 C and optimal discharging temperature is between -20 C to 55 C). This in turn assists in managing the depth of discharge, prevents cell voltage from falling below the tolerance limit, and prevents over charging of cells which can lead to a fire or explosion. A BMS monitors the temperature at various locations within the cells and also outside each cell and module to prevent any decomposition of the electrode and electrolyte. In addition, a BMS includes an embedded software network which estimates and manages battery state of charge, provides an onboard diagnosis, and manages battery safety control, battery operating parameters, battery equalization (i.e. consistency between all cells within a module), information storage and thermal management.

**Table 2.1 Types of charging facilities**

Type of Charging	Charging* Time	Advantages	Disadvantages	Market Segment
Onboard AC to DC charger - Slow (220 V, 13 A)	24 h	Easy to implement	Slow	Private cars, two-wheeler
AC to DC via special extra converter and DC charging of onboard batteries - Fast	12 h	Moderate, flexibility	More investment	Public cars, public buses
Rapid (50 kW+)	90 min	Fast	Restricted to three phases, high cost, loading issue, low efficiency	Public buses, public cars
Battery swapping	2–5 min	Very fast	Cost of battery, space requirement at EVCPs, robotics	Public buses

Source: GGGI, 2015<sup>31</sup>

\*Estimated

### 2.3 Comparison of Diesel, Hybrid Electric and Full Electric Buses

Diesel, hybrid electric and electric buses all perform differently, and an understanding of these comparative differences is useful. Such a comparison is summarized in Table 2.2 below and includes a range of factors.

Overall, the greatest hurdle to increased uptake of EV is their higher price tag when compared to ICE vehicles. This is mainly attributed to battery costs, the complex design of powertrain systems and nascent technology. Since an HE bus is powered by an ICE, as well as a battery with an electric motor, the HE models cost the most among the three bus segments under discussion.

The number of moving parts in a full electric bus is less than in a diesel bus. On the other hand, HE buses have more moving parts, making their design the most complicated amongst the three vehicle types. Therefore, diesel and HE buses have higher maintenance requirements as compared with those of BE buses. The types of maintenance in diesel buses include frequent oil changes, filter replacements, periodic tune ups, exhaust system repairs, water pump, fuel pump and alternator replacements, etc. The maintenance requirement for HE buses can be similar, or higher, than those of diesel buses.

Battery electric buses have controllers and chargers, which manage the power and stored energy levels in the battery. These are electronic devices without any moving parts, and, hence, they require little or no maintenance. The lithium-

ion batteries that are used in electric buses require minimal maintenance. Battery replacement is one type of maintenance, which may need to be undertaken every several years. However, continual technological advancement aims to make batteries co-terminus with the service life of a bus.

Battery charging, which is similar to refueling, is not considered maintenance work, even though it contributes to significant downtime in bus operations. In developed electricity markets, due to a time of usage (ToU) tariff policy, off-peak charging allows the application of lowest utility rates, leading to significant operating cost advantages. In this way, the total cost of operating a BE bus is less than an ICE bus due to lower maintenance, cheap power and high fuel efficiency. However, BE buses are more expensive to acquire initially, a result of a higher price tag on the bus itself, and the need to install charging facilities.

Diesel hybrid buses typically demonstrate 7-44% better fuel economy than diesel buses at slow and medium speeds. However, the fuel economy for the hybrid bus is reported to be the same, or lower, than the diesel bus at high speeds. The majority of city transport buses (90%) operate at slow or medium speeds.

The external features of the battery electric bus design are similar to those of an ICE bus. The main difference is that BE buses do not have tail pipe emissions. However, the internal design of the components is moderately different among ICE buses, HE buses and battery electric buses.

<sup>31</sup> Global Green Growth Institute, 2015. Electric Buses in India: Technology, Policy and Benefits

**Table 2.2. General comparison of three segments of buses**

Parameters	BE Bus	HE Bus	Diesel Bus
Power source	Electricity	Electricity and diesel	Diesel
Power generator	Battery	ICE and battery	ICE
Costs (NPR)	>1.5-3.5 crores <sup>32</sup>	>4.8 crores <sup>33</sup>	0.32–1.41 crores <sup>34</sup>
Fuel efficiency	1.12 kWh/km <sup>35</sup>	2.75–4 km/L <sup>36</sup>	2.2–3.3 km/L <sup>37</sup>
Fuel tariff	4.69 NPR/kWh <sup>38</sup>	77.5 NPR/L <sup>39</sup>	77.5 NPR/L
Fuel cost <sup>40</sup>	NPR 3.12/km	NPR 19–28/km	NPR 23–35/km
Emissions	Zero (local)	Low (less CO <sub>2</sub> , SO <sub>x</sub> , NO <sub>x</sub> and NMHC)	High (baseline)
Noise	Minimum (at slow speeds)	Low (at slow speeds)	High (baseline)
Secondary benefits	High	Moderate	Low
Maintenance	Lowest	High	High
Components	EV propulsion system, transmission, battery charging system, power accessories, body	ICE propulsion system, EV propulsion system, transmission, battery charging, power accessories, body	ICE propulsion system, transmission, power accessories, body

Source: GGGI, 2015<sup>41</sup>

According to California’s Advanced Transportation Consortium, up to 70% of the components of an electric bus can be different from those of an ICE bus. Diesel and hybrid electric buses have a distinct feature; both have a

fuel tank, which is absent in BE buses. Diesel buses have only one energy source, ICE, which uses diesel fuel. A HE bus contains both an ICE and a battery pack with an electric motor.

<sup>32</sup>Global Green Growth Institute. 2014. “Green Growth Strategy for Karnataka.” Case Studies. [http://gggi.org/wp-content/uploads/2014/12/Karnataka-GG-Case-Studies\\_FINAL\\_Web-Version.pdf](http://gggi.org/wp-content/uploads/2014/12/Karnataka-GG-Case-Studies_FINAL_Web-Version.pdf).

<sup>33</sup>Noel, Lance, and Regina McCormack. 2014. “A Cost Benefit Analysis of a V2G-Capable Electric School Bus Compared to a Traditional Diesel School Bus.” Applied Energy. <http://www.udel.edu/V2G/resources/V2G-Cost-Benefit-Analysis-Noel-McCormack-Applied-Energy-As-Accepted.pdf>.

<sup>34</sup>Adapted from a range of global studies exploring fuel efficiency of battery electric buses. Also see Global Green Growth Institute. 2014. “Green Growth Strategy for Karnataka.” Case Studies. [http://gggi.org/wp-content/uploads/2014/12/Karnataka-GG-Case-Studies\\_FINAL\\_Web-Version.pdf](http://gggi.org/wp-content/uploads/2014/12/Karnataka-GG-Case-Studies_FINAL_Web-Version.pdf).; Truckaurbus.com. 2015. “Tata Starbus 32 AC (BS4), ₹ 20,19,000.” August 23. <http://www.truckaurbus.com/new-cv/tata/starbus/tata-starbus-32-ac-bs4-8377-20-19-000-11232.html>.

<sup>35</sup>Global Green Growth Institute. 2014. “Green Growth Strategy for Karnataka.” Case Studies. [http://gggi.org/wp-content/uploads/2014/12/Karnataka-GG-Case-Studies\\_FINAL\\_Web-Version.pdf](http://gggi.org/wp-content/uploads/2014/12/Karnataka-GG-Case-Studies_FINAL_Web-Version.pdf).

<sup>36</sup>M.J. Bradley & Associates LLC. n.d. “Comparison of Modern CNG, Diesel and Diesel Hybrid-Electric Transit Buses: Efficiency & Environmental Performance.” <http://mjbradley.com/sites/default/files/CNG%20Diesel%20Hybrid%20Comparison%20FINAL%2005nov13.pdf>.

<sup>37</sup>Global Green Growth Institute. 2014. “Green Growth Strategy for Karnataka.” Case Studies. [http://gggi.org/wp-content/uploads/2014/12/Karnataka-GG-Case-Studies\\_FINAL\\_Web-Version.pdf](http://gggi.org/wp-content/uploads/2014/12/Karnataka-GG-Case-Studies_FINAL_Web-Version.pdf).

<sup>38</sup>Nepal Electricity Authority. 2016. Annual Report.

<sup>39</sup>Nepal Oil Corporation. 2017. Oil prices.

<sup>40</sup>Fuel cost per km is calculated using fuel efficiency and fuel tariff.

<sup>41</sup>Global Green Growth Institute, 2015. Electric Buses in India: Technology, Policy and Benefits

वर् रत्नपार्क-पुरानो बसपा



श यातायात

## Chapter 3

# BENEFITS AND CHALLENGES OF BATTERY ELECTRIC VEHICLES

### 3.1 Introduction

Numerous benefits are associated to introduction electric vehicles in Nepal. Sajha Yatayat's vision to adopt a fleet of pure battery electric buses, starting from the pilot initiative, has evolved from the recognition of multiple benefits such as improved operations, environmental quality, enhanced socio-economic conditions with a positive impact on tourism and associated business opportunities. Study of electric bus fleet operations in Himachal Pradesh and Karnataka in India by GGGI has provided a solid basis for assessing the costs and benefits of running electric buses in the roads of Kathmandu (see Annex 3 for detailed discussion on Himachal Pradesh and Karnataka case studies). The key technical, environmental, social and economic benefits viewed in the context of the Kathmandu are presented below.

### 3.1. Technology

#### 3.1.1 Torque and Power Curves

Most local buses ply at speeds in the range of 10-30 km/hr. Even then, climbing maximum gradients of 4-12% at speeds 12-20 km/hr specified in Nepal Roads Standards 2070, demands a much greater power requirement to sustain such slopes for longer durations. Diesel engines inefficiently generate such torques as engine runs at a much higher rpm to deliver required power. Electric buses on the other hand are capable of providing greater torques at slow speeds without much loss of efficiency.

#### 3.1.2 Reduced Maintenance Cost

The hilly terrain as well as poor road conditions has a negative impact on the overall machinery of diesel buses. It is observed that the scheduled servicing of buses in

Kathmandu occurs at a lower value of cumulative km (7,000-8,000 km) than that recommended by the manufacturer (15,000 km). Electric buses on the other hand have an advantage on both hilly and flat routes. This is owing to the absence of a mechanical drive train. Due to significantly less number of moving parts in an electric bus, it is a preferred option against diesel buses. The maintenance cost analysis detailed later in the report, indicates 90% reduction in maintenance cost for electric buses, when both direct and indirect costs are captured for diesel buses undergoing repair and maintenance.

#### 3.1.3 Performance at Low Temperature

Kathmandu experiences overnight lows of 2°C during winter. Diesel buses incur extra costs at such low temperatures because diesel gels. Thus, electric vehicles are more efficient during winter in Kathmandu.

#### 3.1.4 Challenges

The main technology challenges include:

- **Weight of vehicle and batteries** - Electrical vehicles have to carry the dead weight of batteries at all times irrespective of energy content in them. To support additional weight of batteries the vehicle structure is redesigned which adds weight. Such additional weight of vehicle and batteries consumes energy to move.
- **Range** - Net amount of energy on board an electric bus adds to the curb weight of electric bus. Thus, suitable sizing of batteries is required to meet operational requirements at optimum energy (thus weight) levels.
- **Concurrent development of charging infrastructure** - The range anxiety and refueling concerns can only be addressed by a reliable charging infrastructure. A thriving electric bus ecosystem would need a supporting network of charging stations.

## 3.2. Environment

Apart from offering superior performance than ICE vehicles, Electric vehicles also offer major environmental benefits due to their inherent technological design where they have zero tail pipe gas emissions and significantly low noise levels.

### 3.2.1 Improved Air Quality

Diesel vehicles are a major source of air pollution. Correspondingly, Kathmandu is one of the most polluted cities in Nepal due greenhouse gas (GHG) emissions (complete combustion of 1 l of diesel causes 2.65 kg of CO<sub>2</sub> emissions, density of diesel = 835 g/l) and particulate matter emissions from diesel buses. The impact of these emissions is further worsened by congestion and directly harmful to the individuals caught in traffic. With the growing number of vehicles on road, the direct impact of air pollution will be felt even more.

Air quality benefits from electric buses can be attributed to a reduction in local air pollution compared with that of conventional diesel buses. Electric buses contribute to zero

tail-pipe emissions, which are a major source of air pollution in urban areas. The introduction of electric buses will be beneficial in urban areas, where local air pollution is a concern. Electric buses combined with renewable electricity will ensure future reduction in fossil fuel demand and a way forward for cleaner technologies and fuels.

### 3.2.2 Reduced Noise Pollution

Noise pollution is linked to several health issues, including stroke, hypertension, dementia and coronary heart disease. In addition to these concerns are the less serious but more prevalent issues of annoyance and sleep disturbance, which in itself can have an added cost in the workplace or classroom the next day. Further still, one can also consider the effects of excess noise pollution on economic productivity; it not only causes health problems, but also decreases economic efficiency. The benefits on health due to electric vehicles are substantial. Noise pollution is significantly reduced when switching from a diesel vehicle to an electric vehicle.

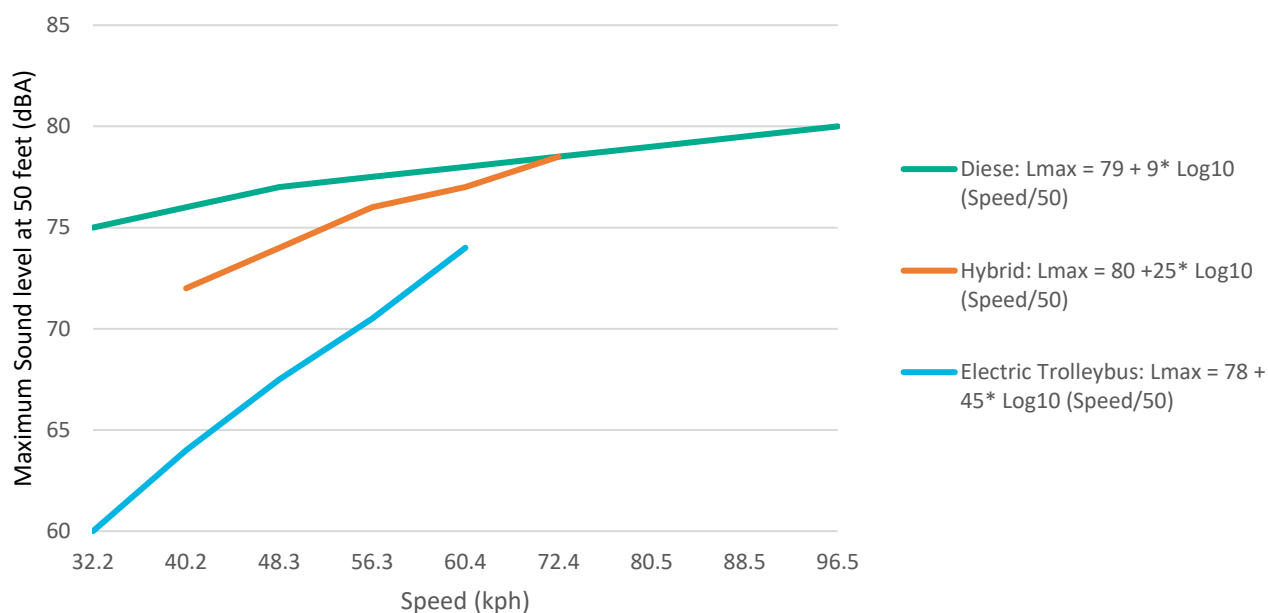

Source: Rose and Staiano, 2007<sup>42</sup>

Figure 3.1. Bus categories, travel speed and associated noise levels.

<sup>42</sup> Rose, Jason C, and Michael A Staiano. 2007. "A Comparison of Green and Conventional Diesel Bus Noise Levels." In . Reno, Nevada. [http://staianoengineering.com/images/NC07\\_Ross\\_Staiano\\_-\\_A\\_comparison\\_of\\_green\\_and\\_conv.pdf](http://staianoengineering.com/images/NC07_Ross_Staiano_-_A_comparison_of_green_and_conv.pdf).



Generally, electric vehicles are quieter than diesel vehicles, for example, at low speeds, an electric bus is about 17 decibels (dB) quieter than a diesel bus travelling at the same speed. Fossil fuel buses can produce noise that is as loud as 72 dB, whereas electric buses tend to operate at about 64 dB at higher speeds. Since dB is on a logarithmic scale, this means that electric buses are half as loud as diesel buses. This is equally true for other vehicle categories, such as 2-wheelers and cars. Such a significant reduction in noise “at the source” has the potential to have a significant impact on well-being.

It is important to note, however, that at high speeds, all types of large vehicles, especially buses, generate roughly the same amount of noise, as the main source of noise is the tires on the pavement and not the engine. According to a study, the difference between the noise levels generated by larger vehicles such as diesel and electric buses is most significant at speeds up to 25 mph (40 kmph) (Rose and Staiano 2007) as shown in Figure 3.1. However, mobility indicators for vehicles in Nepal urban driving conditions show that traffic rarely exceeds these speeds. Thus, the reduction in noise from electric vehicles will be quite tangible in the context of urban Nepal.

### 3.2.3 Reduced Greenhouse Gas Emissions

Introduction of electric buses becomes favorable in regions where the grid has a major share from renewable energy. This is the case in Nepal, where hydropower is the primary source, accounting from 70-80% of Nepal’s electricity, with the remainder being imported from India.<sup>43</sup> The total hydropower potential of Nepal is estimated at 83,000 MW. When the electric buses are charged using electricity generated by renewable energy, the benefits are way beyond the local air quality.

### 3.2.4 Challenges

The main environmental challenge lies in battery disposal. All modern batteries use rare and/ or poisonous materials (lithium, lead etc.), thus proper disposal after use is an environmental challenge to avoid any chance of local pollution.

## 3.3. Socio-Economic

Some of the socio-economic benefits of using electric buses are as below:

<sup>43</sup> See <http://www.nepalenergyforum.com/260-mw-to-be-imported-from-india/>

<sup>44</sup> Diesel bus consumes about 15,884 l of diesel per year (approx. 1.5 GWh energy per year) -Assumption: Energy required by electric bus =

### 3.3.1 Energy Security

Replacement of diesel buses with electric buses can improve energy security of the country. When compared to a Sajha Yatayat diesel bus, in the Lagankhel to Budhanilkantha route, an electric bus consumes 65,522 kWh of electricity per year for operation, which is 4% of the energy consumed by a diesel bus.<sup>44</sup> Implementation of Electric Vehicles are directly related to decreasing reliance on other countries for fossil fuel imports- All the fossil fuel being consumed in the transport as well as the residential sectors in Nepal is imported, which presents a serious threat to the country’s energy security. Reliance on only one source of fuel to run priority sectors of the country limits its growth. Implementation of electric vehicles in priority areas will also ensure environmental sustainability and help diversify the energy-mix, which also aligns with GoN’s aim to limit the use of petroleum products. Since Nepal aims to develop 10,000 MW hydropower capacity by 2025 as outlined in the National Energy Crisis Reduction and Electricity Development Decade Plan (2016), the electricity generated can be supplied to the transport sector, thereby reducing the burden of importing fossil fuels. An increase in its energy mix can aid the country in greatly enhancing its energy security.

### 3.3.2 Dynamic Charging

Nepal has an estimated 43,000 MW of hydroelectric potential of which 904 MW has been harnessed and 3833 MW is under construction as of September 2017, (DoED, 2017). This capacity has been installed by National level and Private sector entities. Usage of this renewable energy source for operation of electric buses will result in a robust and environmentally sustainable mobility solution.

### 3.3.3 Lower Price Volatility

The commercial rate of per unit cost of electricity has remained far more stable than the cost of petroleum products, which have fluctuated over the past 2-3 years. Every hike in price of diesel due to negative externalities, causes the public bus operating companies to incur losses, since a corresponding increase in the bus fare is not an option. Bus operators are not permitted to alter bus fares to reflect actual costs of doing business. Rather, the federal government sets bus fares across the board. Thus, it might be fiscally prudent for public bus operating companies, such as Sajha Yatayat to move to a basket of clean technologies including electric vehicles whose prices are largely stable.

1.50kWh/km, Mileage of diesel bus = 2.7 km/l, Avg. km travelled per bus per year = 43,681km]

### 3.3.4 Increased Road Safety

A shift from clutch gear system (conventional diesel bus) to automatic drive (electric bus) would be more comfortable [11] and reduce the fatigue experienced by drivers, especially those logging overtime hours. A corresponding increase in road safety can also be envisaged due to automatic buses and better driver control.

### 3.3.5 Increased Comfort and Ease of Access

New electric buses are equipped with AC and have higher quality seats than the existing diesel buses in Sajha Yatayat's fleet. As such, electric buses tend to be more comfortable.

In addition, as is the case with diesel buses in Sajha Yatayat's fleet, electric buses will have seats reserved for women and children, helping to ensure their security and comfort while travelling. The proposed electric buses are low-floor buses, whereas Sajha Yatayat's existing diesel buses are almost all high-floor buses. It is much harder for users in wheelchairs and the elderly to access these buses due to the high steps. However, low-floor electric buses are much easier to access as there is no step between the curb and the bus floor. In addition, access is improved as a result of an extendable ramp for wheelchair users and the elderly, as well as special reserved wheelchair spaces on the bus.

### 3.3.6 Job Creation

The operation of electric buses requires the same human resource inputs as diesel buses in terms of drivers, conductors and depot staff. However, due to much less servicing and maintenance, electric buses require less time from technicians, reducing demand for jobs in this area. However, outside of servicing, electric buses generate other job opportunities. Growth in the EV sector will produce direct and indirect jobs. The development of certain sectors in Nepal, such as vehicle manufacturing along with

development of batteries, charging stations and other EV-related accessories would result in direct job creation. The potential for job creation can be gauged from the instance of EV manufacturing in China. Evidence from that country suggests that the manufacture of EVs can constitute 15% of the total automobile production. The Chinese government has an official program that aims to produce 1.67 million new EVs and create of 1.2 million jobs annually from 2010–2020.

Introduction of EVs has also provided the lower income population with job opportunities. There have been many examples of development partners supporting country governments to implement clean transport services. An example of such an effort is the introduction of electric three-wheelers in Kathmandu Valley in 1993 that has empowered both females and disadvantaged populations. In addition to this, ADB piloted electric pedicabs in Kathmandu and Lumbini in April 2017 in a bid to provide employment opportunities to people from the low-income group.<sup>45</sup> Another such example, but at a significantly larger scale, was implementation of 100,000 electric three-wheelers in Manila, Philippines. This project was aimed at not only curbing local pollutant emissions and managing traffic but also in boosting income of the low-income drives in the country (IEA, 2014). Such examples are effective in illustrating the opportunities clean vehicles can provide to low-income population in-terms of income generation.

### 3.3.7 Challenges

Electric cars have recently been introduced in Nepal. There are no cases of electric bus manufacturing systems or deployment in regular operations yet. The ecosystem that supports electric vehicles and electric bus on an industrial scale is still evolving. This offers a challenge as well as opportunity to Nepal to create demand for required manufacturing units to support deployment of electric buses in the country.

---

<sup>45</sup> Support Global Voices. 2017. [The Pedicab Project Is Giving Nepal's Rickshaws a Modern Update](https://globalvoices.org/2017/06/01/the-pedicab-project-is-giving-nepals-rickshaws-a-modern-update/). Retrieved from

<https://globalvoices.org/2017/06/01/the-pedicab-project-is-giving-nepals-rickshaws-a-modern-update/>

## Chapter 4

# REGULATORY LANDSCAPE

### 4.1 Introduction

In recent years, air pollution has become the cause of concern in numerous urban centers across Nepal, especially Kathmandu. Increasing imports of oil due to an increasing number of fossil fuel vehicles is causing environmental degradation, creating public health risk, and undermining the energy security of the country.

Since cleaner modes of transport, such as electric vehicles, have numerous co-benefits (as discussed in Chapter 3) ranging from improved air quality to job creation, the government has realized the necessity of shifting to environmentally friendly transport services in the country, and have set about translating this objective into different policy and regulatory measures, creating a wide, quite comprehensive and increasingly robust policy landscape for EV. A summary of this policy landscape is presented below.

### 4.2. Summary of Policies and Regulation

#### 4.2.1 Fourteenth Three Year Plan (2016)

The Fourteenth Three Year Plan (2016/17 to 2018/19) recognizes the need to identify sustainable transport services and implement an electric railway connecting the east and the west of the country. It also states that a study for possibility of metro or monorail service in Kathmandu is being carried out. Disruption to Nepal's fuel supply during 2015-2016 made government planning bodies more cognizant of the need to reduce dependence on imported fossil fuel in addition to decreasing pollution in the capital city<sup>46</sup>. The proposed electric bus pilot initiative can be a start to the change that NPC has envisioned for 2018/19.

#### 4.2.2 National Transport Policy (2001)

The National Transport Policy is an overarching policy document which is aimed at providing clean transport services (powered by gas, electricity and solar) in order to manage air and noise pollution levels in Nepal, particularly from public transport, in addition to building sustainable transport infrastructure. It covers key components of the transport system, including developing infrastructure to connect Strategic Road Networks to Local Road Networks as well as ensuring public transport services (vehicles powered by gas and electricity) are sustainable and reliable through the introduction of different standards.

#### 4.2.3 Environment Friendly Transport Policy (2014)

Whereas the National Transport Policy only broadly specifies provisions for clean transport services, the Environment Friendly Transport Policy 2014/15 sets specific targets related to clean transport. These include some critical electric transport targets, such as:

- Increasing the share of what the policy terms "environment friendly vehicles" to a minimum of 20% of the total vehicle fleet by 2020;
- Encourage manufacturing of environment friendly vehicles, which include electric vehicles
- Encourage private sector to invest in construction and management of EV parking stations as well as service centers.
- Facilitate land for construction of 10 charging stations around ring-road in Kathmandu under a pilot initiative. In addition, specify provisions for

---

<sup>46</sup> NPC. 2017. Fourteenth Three Year Plan 2073/74-75/76. National Planning Commission. Government of Nepal.

installing charging facilities in retail outlets such as shopping malls, hotels and large parking areas.

- To ease access to batteries, chargers, motor, controller and chassis related to environment friendly vehicles

These targets provide substantial support to programs that aim at strengthening clean transport services, specifically EVs, in the Nepalese market<sup>47</sup>. In addition to unlocking opportunities for EV sales and retrofitting existing vehicles to a hybrid system, this policy and its targets also recognizes the need to kick-start the electric vehicle manufacturing industry to increase local job opportunities, decrease production costs and encourage local resource use.

#### 4.2.4 National Sustainable Transport Strategy (NSTS) (2015)

The National Sustainable Transport Strategy<sup>48</sup> provides overall strategic direction to strengthen the economic, social and environmental indicators in providing sustainable transport solutions in the country. The strategy was drafted in 2015, but is still awaiting approval by Cabinet.

In addition to streamlining existing strategies and guidelines on transport to make it more robust, the NSTS specifies strategic actions necessary for a sustainable transport system. Some of these strategic actions pertain to electric vehicles, including:

- Encourage investment in electric railway projects;
- Introduce trolley buses or electric buses in urban areas; and
- Provide electric vehicles in tourist areas.

The strategy emphasizes that escalating hydropower generation in the country will provide numerous opportunities to integrate electric vehicles (EVs), both for passenger and freight transport, into the transport system (UNCRD, 2015). The commitment to initially piloting electric buses to provide cleaner and more sustainable mode of transport services is in line with the actions outlined in the National Sustainable Transport Strategy.

#### 4.2.5 National Urban Development Strategy (2017)

The National Urban Development Strategy recognizes the growing concern for air pollution and the need for sustainable urban public transport systems to cater to the demand of Nepal's rising urban population. The NUDS (2017)<sup>49</sup> presents a range of strategies to improve public transport services in urban areas through:

- Integrating land-use and transportation by developing related institutional mechanisms and capacity;
- Providing balanced urban road infrastructure;
- Promoting sustainable urban public transport; and
- Preparing comprehensive transport management standards and plans.

This strategy document emphasizes the need to enhance inter-urban connectivity through route planning to introduce Bus Rapid Transit (BRT), Light Rail Transit (LRT) and Mass Rapid Transit (MRT) in metropolitan cities and improving institutional mechanisms to regulate public transport.

#### 4.2.6 Fiscal and Financial Regulation

Recognizing the importance of fiscal measures to accelerate EV adoption, the Ministry of Finance has gradually shifted its attention to decreasing duties for both small and large EVs in its recent Budget Speech of FY 2016/17. The following fiscal parameters are in place, as outlined in the Ministry of Finances Budget Speech of 2016/2017<sup>50</sup>:

##### **For electric vehicles for public transport:**

- A customs (import) duty of 1% is in place (compared to a customs duty of 5% for fossil fuel vehicles with more than 40 seats for public transport mentioned in the Budget Speech for FY 2015/16);
- Exemption of value added tax (compared to a VAT of 13 % levied on fossil fuel vehicles for public transport);

##### **For electric vehicles for private transport:**

- A customs (import) duty of 10 % is in place (compared to a customs duty of 80 % for fossil fuel vehicles for private usage);

<sup>47</sup> Ministry of Physical Infrastructure and Transport. 2015. Environmentally Friendly Transport Policy 2015. Government of Nepal.

<http://www.mopit.gov.np/uploads/files/policies&directives/Watawaranmaitri%20Sawari%20tatha%20Yatayat%20Niti%202071.pdf>.

<sup>48</sup> United Nations Centre for Regional Development, 2015. National Sustainable Transport Strategy. Ministry of Physical Infrastructure and Transport (MOPIT), Nepal Ministry of the Environment (MOE), Japan

United Nations Economic and Social Commission for Asia and the Pacific (UN ESCAP).

<sup>49</sup> Ministry of Urban Development. 2017. National Urban Development Strategy 2017, Nepal. Urban Development and Physical Planning Division. Ministry of Urban Development (MoUD). Government of Nepal (GoN).

<sup>50</sup> Ministry of Finance. 2016. Budget Speech 2016/17

- Exemption of value added tax (compared to a VAT of 13 % levied on fossil fuel vehicles for private usage);

**For battery recycling equipment:**

- A customs duty of 1 % is in place on machinery and equipment used for the recycling of batteries;

**For electric rickshaw parts:**

- Exemption of value added tax (compared to a VAT of 13 % levied on fossil fuel vehicle parts).

In addition to this, Nepal Rastra Bank in its Monetary Policy for FY 2074/75 has set the loan-to-value ratio for private loans used by consumers to purchase electric vehicles to 80% of the vehicles value, whereas the same for fossil fuel vehicles is only at 65%<sup>51</sup>. This policy came into effect in July 2017. Interest rates on these loans are high, ranging from 10% at Global IME Bank (a development bank) to 15.5% at the NMB Bank (a commercial bank).

#### 4.2.7 Climate Change Policy 2011

The Climate Change Policy<sup>52</sup> is the principal document outlining the government’s objectives and targets specific to climate change mitigation and adaptation in the country. As part of a suite of measures designed to expedite low carbon development, reduce greenhouse gas emissions and build climate resilience, the document highlights the importance of promoting electric transport industries such as electric train, ropeway and cable car.

The electric bus pilot initiative can potentially jumpstart adoption of electric vehicles in the public transport sector throughout the country, and facilitate a reduction in greenhouse gas emissions, supporting wider climate change mitigation efforts in Nepal. In this way, the pilot program will be a step towards meeting the objectives of the Climate Change Policy.

#### 4.2.8 Nationally Determined Contributions

Nepal has prepared its Nationally Determined Contributions (NDCs)<sup>53</sup>, which is a collection of sectoral plans and policies that provide the building blocks for addressing climate change in Nepal. The NDC was prepared in 2015 and constitutes Nepal’s international commitments submitted at the 2015 Paris Climate Conference or 21<sup>st</sup> Conference of Parties (COP21).

<sup>51</sup> NRB. 2017. Summary of Monetary Policy for Fiscal Year 2074/75. Nepal Rastra Bank, Nepal.

<sup>52</sup> Ministry of Environment. 2011. Climate Change Policy. Government of Nepal.

<sup>53</sup> Ministry of Population and Environment. 2016. Nationally Determined Contribution. Communicated to United Nations Framework Convention

The NDCs include a list of sectoral and cross-cutting actions and targets that will contribute to economic growth and reduce greenhouse gas emissions. Air pollution and emission mitigation from the transport sector through implementation of clean transport services are priority areas in Nepal’s NDCs as pointed out as follows:

- NDC Action Point 9: By 2020, Nepal aims to increase the share of electric vehicle up to 20% from 2010 level.
- NDC Action Point 10: By 2050, Nepal will decrease its dependency on fossils in the transport sector by 50% through effective mass public transport means while promoting energy efficient and electrical vehicles.
- NDC Action Point 11: Nepal will develop its electrical (hydro-powered) rail network by 2040 to support mass transportation of goods and public commuting.
- NDC Action Point 14: By 2025, Nepal will strive to decrease the rate of air pollution through proper monitoring of sources of air pollutants like wastes, old and unmaintained vehicles, and industries.

#### 4.2.9 Sustainable Development Goals

Implementation of programs in achieving the sustainable development goals (SDGs) is a major objective of the Government of Nepal for low emissions development and sustainable use of its vast natural resource base. Specifically, in response to the global adoption of the SDGs, the Government of Nepal’s National Planning Commission prepared the Sustainable Development Goals 2016-2030 National (Preliminary) Report<sup>54</sup> which outlined focus and priority areas for SDG implementation in Nepal. The report outlines target specific to each of the goals. Under this report, the introduction and widespread adoption of EVs in the country is supported by five SDGs, as set out below, namely:

- SDG 3: Ensure healthy lives and promote well-being for all at all ages  
Target 3.4a1: Reduce death of population aged 30-70 years from cardiovascular diseases, chronic respiratory diseases, cancers and diabetes from 22% in 2014 to 16.5% in 2020 and 7.3% in 2030.

on Climate Change, Ministry of Population and Environment (MoPE). Government of Nepal (GoN)

<sup>54</sup> Nepal Planning Commission. 2015. Sustainable Development Goals 2016-2030. National (Preliminary) Report. National Planning Commission (NPC). Government of Nepal.  
[http://www.npc.gov.np/images/category/23rd\\_Jan\\_final\\_for\\_print\\_Sustainable\\_DevelopmentGoals1.pdf](http://www.npc.gov.np/images/category/23rd_Jan_final_for_print_Sustainable_DevelopmentGoals1.pdf)

- SDG 7: Ensure access to affordable, reliable, sustainable and modern energy for all
  - Target 7.3g: 50% electric vehicles in the public transport system by 2022 and 100% by 2030.
- SDG 11: Make cities inclusive, safe, resilient and sustainable
  - Target 11.2b: 25.1% availability of safe public transport system by 2022 and 50% by 2030.
- SDG 13: Take urgent action to combat climate change and its impacts
  - Target 13.1c: Reduce greenhouse gas (GHG) emitted by transport sector from 12% in 2014 to 6% in 2030.
- SDG 17: Revitalize the global partnership for sustainable development

The electric bus pilot program can initiate the process of contributing to the meeting of targets specified. This initiative can specifically support the meeting of SDG 7 target 7.3.

#### 4.2.10 National Ambient Air Quality Standards

In order to address the rising challenges of air pollution in Nepali cities, the National Ambient Air Quality Standards of Nepal was revised in 2012 by the Department of Environment. This revision introduced new standards for PM2.5 emissions. The target states that PM2.5 concentration can only exceed 40 µg/m<sup>3</sup> for 18 days per year. However, in many larger cities, PM2.5 concentrations regularly exceed this level. In Kathmandu, for example, PM2.5 exceeds this level on an estimated 90% of days.

Since the transport sector largely contributes to PM2.5 emissions, increased adoption of electric vehicles can substantially reduce PM2.5 emissions to meet this target<sup>55</sup>

---

<sup>55</sup> Ministry of Science Technology and Environment. 2012. National Ambient Air Quality Standard

#### 5.1 Introduction

Given the range of high-level policy, regulatory and fiscal support for electric vehicles in Nepal, as explored in the preceding chapter, public transport operators are in an increasingly favorable position to deploy electric vehicles in their fleets. Indeed, many small transport operators in Kathmandu, such as minivan and microbus operators are exploring and have deployed electric vehicles. However, to date, no operators of full size public transport vehicles have deployed electric vehicles within their fleets.

This chapter sets out the parameters for changing this. The chapter analyzes the current conditions and terrain in Kathmandu, by far the largest of Nepal's cities, and explores the current routes and operations of the Nepal's and Kathmandu's largest public bus operator, Sajha Yatayat. An analysis of Sajha Yatayat's operations allows for the identification of the most favorable route for electric buses and sets out the trip parameters and vehicle specifications required to most optimally meet these parameters. Based on this, two electric buses are proposed as viable vehicle options.

#### 5.2 Local Conditions in Kathmandu and Advantages for Electric Buses

When compared to diesel buses, electric buses can present certain distinct advantages (as discussed in Chapter 3). These advantages are realized when certain terrain, climatic and route conditions are present. The following key conditions in Kathmandu all generate an advantage for electric buses over diesel buses.

Advantages include:

- **Better bus performance in hilly terrain** – The efficiency of diesel buses is lower than that of electric buses in hilly areas. As a valley, the Kathmandu metropolitan region (comprising Kathmandu, Lalitpur and Bhaktapur) is largely hill. In particular, on the route under consideration, from Lagankhel to Budhanilkantha, buses travel uphill from Narayangopal Chowk to reach Budhanilkantha, which is located on Shivapuri Hill. When travelling uphill, all buses consume energy as per the weight of the bus and efficiency of traction source. However, unlike electric buses, when travelling downhill, diesel buses lose energy as a result of dissipation of kinetic energy through braking, which leads to high wear and tear on the clutch and brakes. With electric buses, this wear and tear can be significantly avoided, which lowering maintenance costs.
- **Better bus performance in low temperatures** - temperatures in Kathmandu is around 2°C in winter and 28°C during summer. Since electric buses have been operated successfully in Nordic countries and the Rohtang-Manali pass in Himachal Pradesh, India, where sub-zero temperature is normal, the temperature in Kathmandu is optimum for its efficient operation. For a diesel vehicle, diesel has gelling issues at low temperatures and additives are added to diesel to maintain its viscosity causing additional expense. Electric vehicles are limited only by the operating temperature range of batteries. Current batteries (Li-ion) are rated for operation up to -20° C, thus suitable for nominal public transport operation conditions within Kathmandu.
- **Higher stability of electricity prices** – Time of day (ToD) electricity prices for electric vehicles in Nepal

have been relatively stable since 2012 with increase observed once in 2016. Time of day rates have been determined for electric vehicles, specifically Trolley Buses and other vehicles. The off-peak rates jumped by 5% in 2012 and increased from NPR 3.1 per unit in 2012 to NPR 3.7 per unit in 2016. The Nepal Electricity Authority has so far maintained two dedicated lines at the *safa tempo* charging stations, in an effort to reduce losses even during load-shedding hours. This stability in electricity supply and prices for electric buses is highly favorable in Nepal when compared to diesel buses that have to withstand losses due to high fluctuation in diesel price and supply.

- **Better bus performance in start-stop traffic** - The traffic conditions of Kathmandu is such that traffic movement is quite slow. The average speed of any vehicle ranges from 17 to 25 kph. When compared with a diesel bus, electric buses have very high efficiency as conversion, transmission and distribution losses are very low. This puts electric vehicles at an advantage in Kathmandu's roads because at stop-and-go traffic, their energy waste gets minimized (as shown in Table 5.1.).

### 5.3 Sajha Yatayat's Fleet and Operations

Sajha Yatayat is Nepal's largest public transport operator, and one of its best known, operating iconic dark green full-size diesel buses. It's 46 buses operate primarily in Kathmandu Valley, servicing more than 17,000 passengers daily across the metropolitan region. The fleet covers over 6000 kilometers daily, and connects two metropolitan cities, namely, Kathmandu Metropolitan City and Lalitpur Metropolitan City; and three municipalities namely, Budhanilkantha Municipality, Madhya Thimi Municipality and Bhaktapur Municipality.

The organization also services an increasing number of districts neighboring Kathmandu Valley, including Baglung District, some 275 kilometers west of Kathmandu. Talks are ongoing for the introduction of additional routes.

The organization is a cooperative. It began operations in early 1962 with the aim of providing affordable transportation to the population of Kathmandu Valley and increasing connectivity with surrounding districts. During

the 1990s and 2000, the cooperative faced significant operational challenges, a period of intense instability. As a result, the cooperative closed operations in 2007. At the time, Sajha Yatayat owned a fleet of 183 buses.

In 2011, the organization was revived. In April 2013, 16 new buses were procured for operation. In 2016, a further 30 buses were procured and deployed. Until the middle of August 2017, the fleet of 46 full size buses operated across five metropolitan routes, as shown in Figure 5.1 below. From the third week of August 2017, 6 buses were allocated to operate in the sixth route, Ratnapark-Sanga route (see Table 5.3)

#### Box 5.1 Electricity generation in Nepal

Nepal is endowed with 43,000 MW hydropower potential but only 904 MW small and large hydropower plants are in operation so far (as of September 2017). With only 92 MW of storage type hydropower plants in operation, run-off river hydropower plants constitute a significant portion of the hydropower landscape.

There are many hydropower plants that will come into operation in the coming years. Nepal Electricity Authority (NEA) has recently stated that when the 456 MW Upper Tamakoshi Hydropower (run-off river) comes into operation in 2018, there will be excess electricity at night, which can potentially be utilized to charge electric buses.<sup>56</sup> The capacity available during the night, excluding imports from India, is around 570 MW. During the six off-peak hours at night (from 11pm to 5am), electricity demand is around 700 MW. When the 456 MW is added onto the grid in 2018, the total available energy at the grid will be around 1000 MW, with 300 MW excess. This capacity can be used to charge around 6,000 electric buses, with battery capacity of 300 kWh, at night.

Source: Nepal Electricity Authority, 2017<sup>57</sup>

<sup>56</sup> Republica. 2017. NEA setting up charging stations for electric vehicles. Retrieved at: <http://www.myrepublica.com/news/29166/>

<sup>57</sup> Nepal Electricity Authority. 2017. Annual Report.



**Table 5.1 Comparison of energy loss in diesel and battery electric buses**

Loss category	Diesel bus (Wh/km)	Battery electric bus
Aerodynamic losses	90	90
Braking losses	370	20
Wheels losses	350	350
Transmission losses	130	270
Ancillary equipment losses	480	270
Engine/battery losses	2,220	20
<b>Total loss</b>	<b>3,640</b>	<b>1,020</b>

Source: Lajunen, 2015<sup>58</sup>

**Table 5.2 Overview of fleet by 2018**

Make	Model	Quantity	Age	Capacity	Length
Tata Motors	Name <sup>59</sup>	16	2013	40 seats	10 meters
Ashok Leyland	Viking <sup>60</sup>	30	2016	54 seats	11 meters
TBD	TBD	12	2018	40-50 seats	TBD

Source: Sajha Yatayat

**Table 5.3 Ridership of five metropolitan routes**

No	Start	Stop	Length (km)	No. of buses	Av. daily commuters	Av. daily distance (km)
1	New Bus Park	Airport	7	4	1,045	450
2	Swayambhu	Bhaktapur	21	14	5,880	2,450
3	Lagankhel	Bus Park	14.5	12	5,926	1,103
4	Lagankhel	Budhanilkantha	17	8	4,187	825
5	Kathmandu	Baglung	300	2	60	600
6	Ratnapark	Sanga	21	6	1400	650

Source: Sajha Yatayat. All data from July 2017.

<sup>58</sup> Lajunen, Antti. 2015. "Evaluation of Electric Buses." Alto University. [http://www.ecv.fi/@Bin/211333/ECV-seminaaritiesys\\_10-3-2015\\_Evaluation-of-EBuses\\_Antti-Lajunen.pdf](http://www.ecv.fi/@Bin/211333/ECV-seminaaritiesys_10-3-2015_Evaluation-of-EBuses_Antti-Lajunen.pdf)

<sup>59</sup> Model number: LPO/1512

<sup>60</sup> Model number: ALPSV4/186

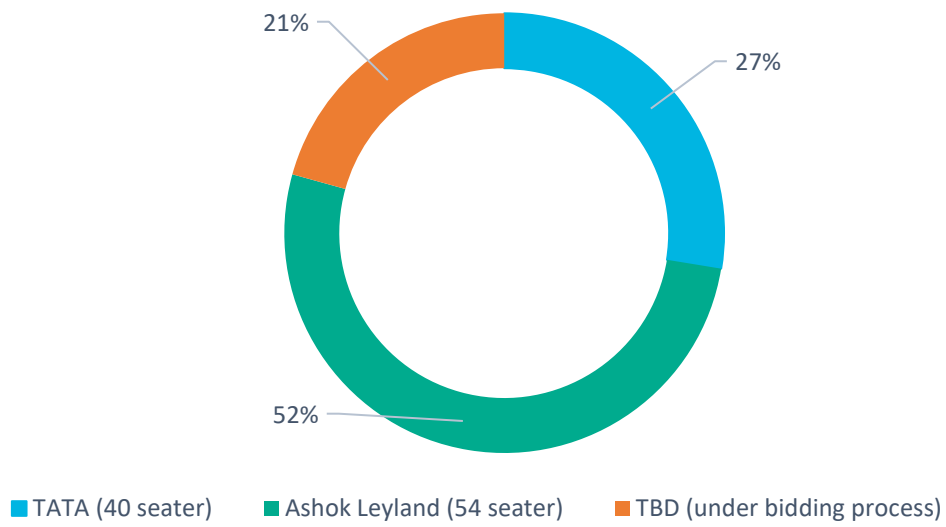

Source: Sajha Yatayat

**Figure 5.1. Composition of projected fleet (2018)**

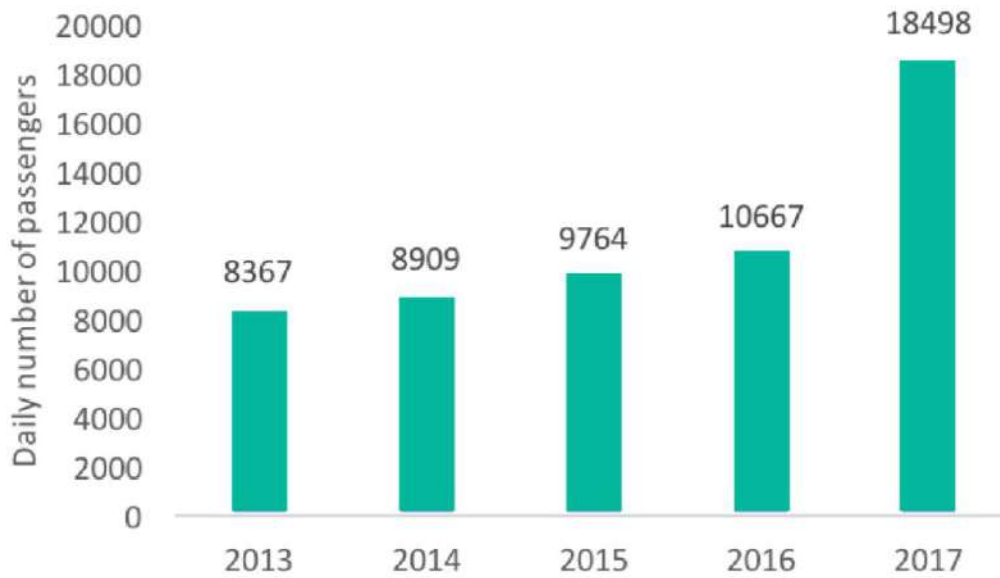

Source: Sajha Yatayat, 2017

**Figure 5.2. Total average daily passengers riding Sajha Yatayat services (2013-2017)**

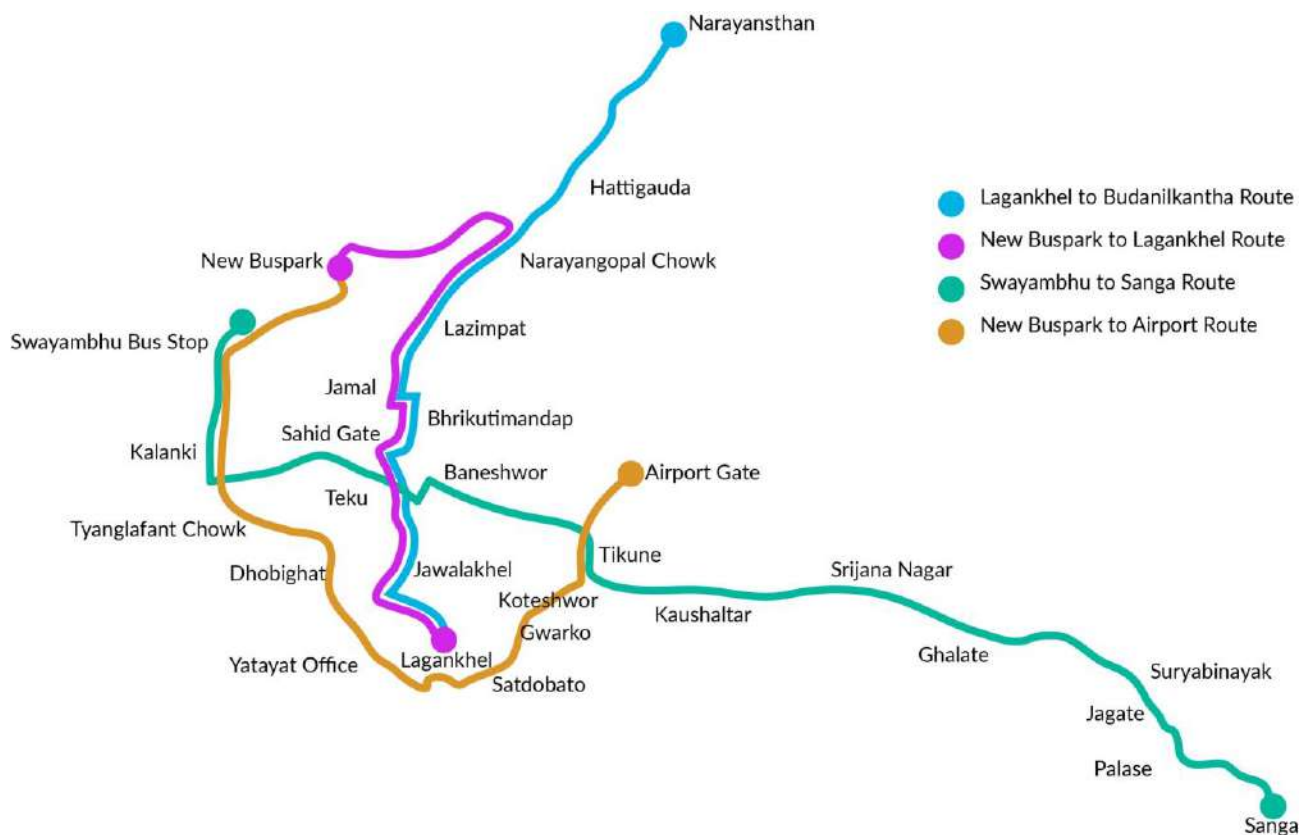

Source: Sajha Yatayat

**Figure 5.3. Six metropolitan routes of Sajha Yatayat**

Its fleet is comprised of two models, one from Ashok Leyland and the other from Tata Motors, both Indian auto manufacturing firms. With the financial contribution of Kathmandu Metropolitan City, a further 12 buses will be procured in 2018, which will take the total projected fleet to 58 buses. An overview of the total projected fleet, including the 2018 procurement, showing bus make, model and capacity is indicated in Table 5.1 below.

As noted below, these buses currently operate across six routes. These routes traverse the Kathmandu metropolitan region, connecting northern and southern extremities and eastern and western extremities, thereby integrating neighboring municipalities and communities into the wider Kathmandu metropolitan system.

The fleet of 46 buses is distributed across these six routes as set out in Table 5.2 below. The fifth route, from Kathmandu to Banglung, was introduced in late 2016. Passenger traffic on this route is significantly lower than on local routes, with the buses only reaching full capacity during special occasions and national holidays, such as Dashain and Tihar. The sixth route, Ratnapark-Sanga, is a

recent addition. This is a 21 km long route in which 6 buses serve around 1400 passengers daily (see Table 5.3).

These services have seen steady growth in passenger numbers. Since 2013, annual average growth in passenger numbers across all routes is estimated to be around 25%, as shown in Figure 5.3 below. Growth is due to management’s sustained decision to provide highest quality public transport possible, with a range of policies to ensure passenger comfort. Naturally, the additional 30 buses introduced in 2016 generated a significant rise in passenger numbers.

### 5.4 Proposed Route for Electric Bus

Following analysis of the above routes, and through discussion with Sajha Yatayat, route number four, from Lagankhel to Budhanilkantha, was selected as the most appropriate upon which to deploy electric buses. This route is 17 kilometers long and takes just over an hour for each bus to complete a single trip (i.e. one way, from terminal to terminal).

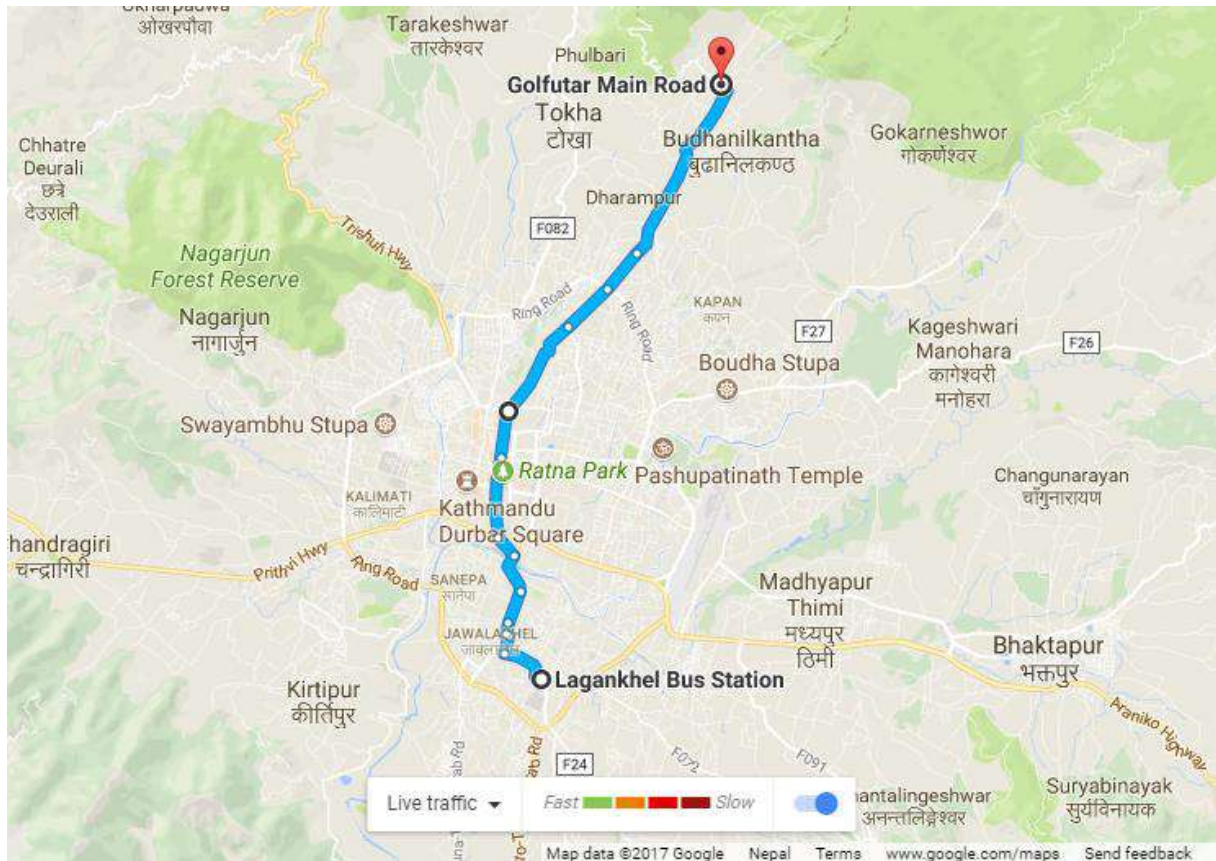

Source: Google Maps 2017

Figure 5.4. Route from Lagankhel – Budhanilkantha

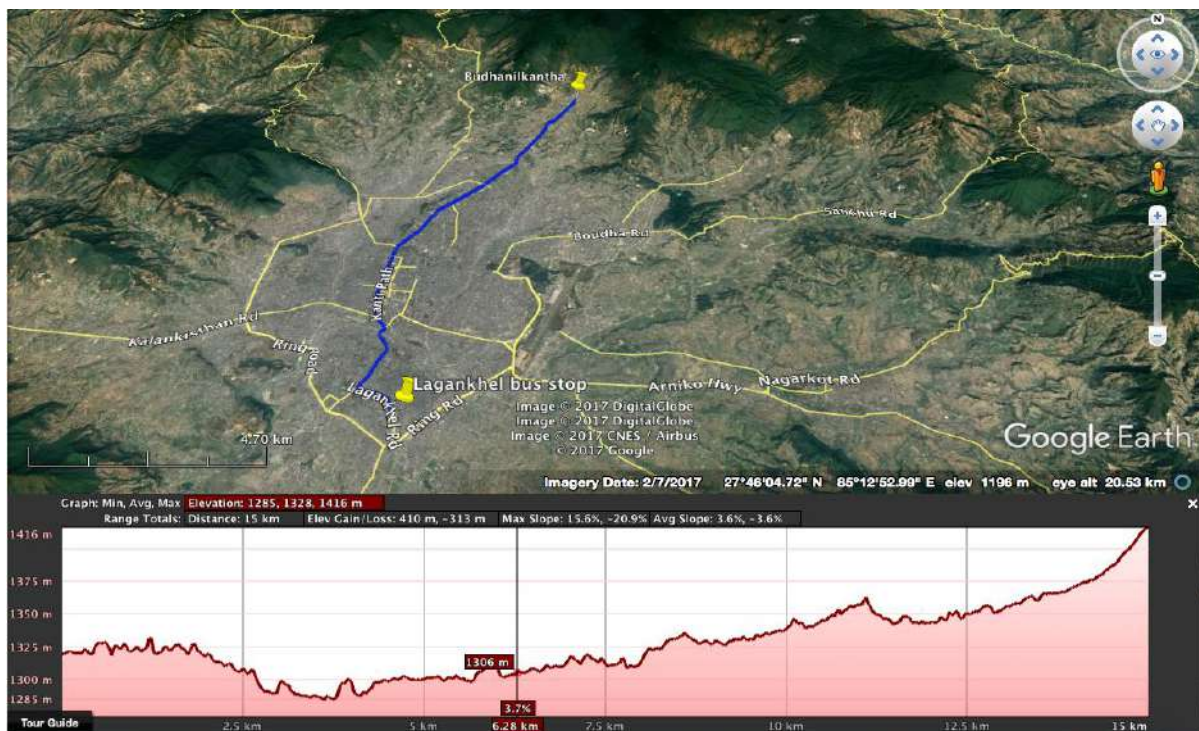

Source: Google Maps 2017

Figure 5.5. Route profile of the Lagankhel - Budhanilkantha route

This selection was based on a range of operational factors, including route length and terrain, as well as strategic longer-term considerations. The major factors are presented below, as rationale.

- **Route length:** The existing Sajha Yatayat bus fleet operating along the Lagankhel to Budhanilkantha route has a one-way distance of 17 km. This route length provides greater advantages to adopting an electric bus as a battery range of around 150 km can be adopted without going beyond the budgetary limits. In addition, feasible charging infrastructure can also be designed and implemented for this distance, especially a normal charging station at the Sajha Yatayat premises in Pulchowk.
- **Greater number of passengers travelling per day:** The Lagankhel-Budhanilkantha route cut across the city and caters to a significant number of daily commuters as shown in Table 5.3. If an electric bus is introduced, more citizens can avail the benefits of traveling in an electric bus that connects the north to the southern areas of the Kathmandu Valley. Since this route falls along the main trunk of the city with Sajha Yatayat availing its services to a large percentage of the population, an electric bus in this route will have maximum promotional power. This will help make the population of the valley more cognizant of the services and benefits provided by an electric bus.
- **Highest number of connector stations along the route:** There are around four stops, among the 28 stops along the Lagankhel – Budhanilkantha route where passenger traffic is relatively higher than the remaining stops. Apart from the Lagankhel stop, from where public transport services head towards destinations in all directions, the Kupondole bus stop, NAC stop and Narayangopal Chowk stop have the largest passenger exchange as these are main connector stations along the route (see Figure 6.5.).
- **Demand for better quality services:** Sajha Yatayat has already been known to provide better service to the population, when compared to other private operators that squeeze in more people than the carrying capacity of the bus. Since the city routes cater to a larger proportion of the working population, there is a strong demand for better service levels in terms of reliability, connectivity

and comfort. Electric buses can provide these facilities in addition to enhancing the air quality and lowering the noise levels.

- **Possibility of charging facilities along route:** There is around 2000 m<sup>2</sup> of area available at Sajha Yatayat where both fast charging and slow charging stations can be installed. Since the Lagankhel-Budhanilkantha route passes through the Sajha Yatayat depot and is at a distance of about 2 km from the Lagankhel terminal, the electric buses could potentially charge between trips at the Sajha Yatayat depot.

A further detailed breakdown of the route and trip parameters follows in Table 5.4 below.

## 5.5 Proposed Vehicle Options

To meet the above route and trip parameters, two electric buses have been identified as viable. The selection of these two options followed a round of consultations with manufacturers in India, United States, China and South Korea. These included, BYD (China), Hyundai (South Korea), and KPIT (United States/India), and Ashok Leyland (India). Discussions with manufacturers centered on the viability of the vehicle in question and scope of vehicle optimization to meet the local conditions and needs in Kathmandu. To a large extent, customization was sought to improve the financial viability of the proposal – i.e. to find the least cost vehicle option.

The overall guide, outside of route and trip parameters presented above, when discussing electric bus options with manufacturers, was to identify full-size bus. This allows the pilot electric bus fleet to directly replace existing diesel bus options currently deployed on the route.

Two electric bus options were identified, one from BYD and one from Ashok Leyland. Due to the relatively low unit volume, the scope for customization of buses was reduced to almost zero. During discussions with manufacturers, a proposed pilot fleet volume of five units was used as the reference. BYD was not able to offer any customization on its vehicle, and Ashok Leyland was able to provide only limited customization.

**Table 5.4. Key route and trip parameters**

Parameter	Unit	Specification
<b>ROUTE</b>		
Route type		Intra-city, commuter
Altitude	m	1400 from MSL
Annual average relative humidity	%	67
Average gradient	%	3.6
Maximum gradient	%	21%**
Climate		Temperate
Ambient temperature	°C	2-28
Terrain		Generally flat, some minor hills
General road conditions		Good; bituminous road with small potholes
<b>TRIP</b>		
Start		Lagankhel Bus Station
End		Narayansthan
Trip distance	km	17 km
Average trip duration	hr/min	1 hr 7 minutes
Average speed	km/hr	17-25
Lunch break duration*	mins	30 – 40
Hours of operation	hr	6:00 – 22:00
First departure	hr	06:00
Last departure	hr	20:30
Buses starting at both ends	Y/N	Y

Source: GGGI

\*Time during which the bus driver and conductor break to eat lunch. This break takes place during one of the terminal stops.

\*\* Indicated gradeability is drawn from Google Earth. The maximum gradient of 21% occurs once on the route but this value does not appear to align with actual road grade. Maximum gradeability is therefore most likely lower. Actual maximum grade should be verified using on-site instruments.

**Table 5.5 Electric bus vehicle specifications**

Parameter	Unit	Specification
Seating capacity	no.	30-50
Standing capacity	no.	10-20
Average daily distance travelled	km	126
Forecast drive range from full charge	km	150
Vehicle length	m	9-11
Turning circle diameter	mm	20,000
Air-conditioning required	Y/N	N
Energy regeneration capability required	Y/N	N
Ground clearance	mm	230

Source: GGGI

Optimization was especially sought on the following parameters:

- **Drive range and battery size** – With a one-way trip length of 17 kilometers, and an average daily distance of 126 kilometers, electric buses were sought that could deliver a drive range of around 150 kilometers per day. A drive range beyond this was excessive to requirements and would result in unutilized battery capacity, unnecessarily inflating price.
- **Air conditioning and battery size** – A non-AC bus is required. This reduces battery capacity significantly and therefore the price of the vehicle. However, BYD was only able to offer current off-the-market models, all of which have AC.

In addition to overall technical specifications of the bus, discussions with manufacturers explored bus charging options. There was overall agreement that overnight

charging at reduced preferential night tariffs was optimum. These slow charging stations would be utilized during the night (from 10 pm to 5 am) when all the buses are at the Sajha Yatayat Depot. Since lunch time for each bus operator (driver and conductor) lasts from between 30 and 45 minutes, overnight charging could be supplemented by fast charging station installed at one of the terminal stations. This would allow a top-up charge to be given to the buses. However, the options proposed below rely solely on overnight charging. In order to obtain further operational savings, Sajha Yatayat may wish to consider reducing the number of charging stations it acquires and using one station per two buses. This would require consecutive overnight charging – i.e. each charging station would charge two buses each night, with each bus requiring 3-4 hours for full charge. An overview of the three bus options, including price range are presented in Table 5.6 below. Price includes for delivery of the vehicle to Kathmandu.

**Table 5.6 Three electric bus options**

Parameter	Unit	Ashok Leyland	BYD	
<b>VEHICLE</b>				
Model		Circuit	K9	K7
Seating capacity	no.	32	44 (2 wheelchair)	25 (2 wheelchair)
Drive range	km	120	260	230
Gradeability	%	-	18%	17%
Vehicle length	m	9	12	8
Air-conditioning	Y/N	N	Y	Y
Battery life	yrs	-	12 years*	12 years*
Battery type		-	Iron Phosphate	Iron Phosphate
Battery capacity	kWh	-	324 kWh	197 kWh
Estimated price <sup>61</sup>	NPR	43 million (USD 389,105)	31 million (USD 272,374)	23 million (USD 224,748)
<b>CHARGING FACILITY</b>				
Method		Overnight	Overnight	Overnight
Charging capacity	kWh	-	80 kWh	80 kWh
Charging time	hrs	-	3-4 hours	3-4 hours
Service center in KTM		No	Yes	Yes
Estimated price	NPR	2 million (USD 18,000)	2 million (USD 18,000)	2 million (USD 18,000)

Source: GGGI, BYD and Ashok Leyland

\* Per BYD warranty

<sup>61</sup> This does not include VAT as the operators are eligible for a VAT refund after purchase of the electric buses

## 5.6 Engagement with Bus Manufacturers

A series of meetings with current and potential electric bus manufacturers from Korea, India and China were carried out to discuss specifications and viability of buses for the market in Nepal. The list of manufacturers that were consulted are presented in Table 5.7 below.

**Table 5.7 Electric bus manufacturers consulted**

Manufacturers	Country
KPIT	India
Tata	India
Ashok Leyland	India
BYD	China
Hyundai	Korea
Woojin,	Korea
Daewoo	Korea
TGM	Korea

Ashok Leyland, Tata and KPIT are two manufacturers that have just started manufacturing electric buses in India. KPIT has a better grip on hybridizing smaller vehicles, such as taxis, and is still developing its expertise in producing electric buses. Ashok Leyland and Tata have also started producing electric buses that can be customized to local conditions, but they have not introduced their electric options in Nepal. BYD, on the other hand, does not provide any options for customization although its presence has been growing in Nepal through sales of electric cars. Korean manufacturers such as Hyundai is producing electric buses to cater to the domestic market only and has not yet ventured into the international market, with the possible exception of China. Woojin, Daewoo and TGM are not offering electric buses on the international market.



### 6.1 Introduction

Following from the analysis of Sajha Yatayat's current fleet, this greenhouse gas analysis explores the emissions reduction potential of replacing the entire fleet with electric buses. With Nepal's electricity generated exclusively from hydro, the emissions associated with electricity are effectively zero (disregarding any emissions associated with construction of hydropower stations, and distribution infrastructure etc.). As a result, the overall favorability of switching to electric buses is heightened. In effect, a switch to electric results in an elimination of GHG emissions – not just a reduction.

This chapter sets out the key assumptions and data points underpinning this GHG emissions analysis. It then presents the key findings of the analysis, including emissions per vehicle and for the whole fleet. While the financial analysis in the next chapter works on a timescale of vehicle lifetime, in this chapter, the analysis is yearly. The environmental and social costs of these GHG emissions, as well as particulate matter emissions, are calculated in the next chapter.

### 6.2 Assumptions and Data

A range of assumptions structure this analysis, and many have direct implications on data. These are presented below. Overall, as much of the operational data as possible was drawn from the management records kept by Sajha Yatayat. A preference for data drawn from actual 'real world' performance of vehicles was maintained throughout

the analysis, over data drawn from test conditions. For example, the fuel economy of Sajha Yatayat's fleet is much higher under test conditions, per manufacturer's specification, than for real world conditions on the road in Kathmandu.

The overall method utilized was of simple extrapolation. Please refer to Annex 1 for the full analysis. Given that Kathmandu Metropolitan City maintains no GHG inventory, and that limited research has been undertaken into GHG emissions at the city-level, it was not possible to compare the calculated fleet GHG emissions against a known actual. Nevertheless, fleet emissions were compared to Indian examples and found to be broadly aligned in value, namely diesel bus fleet of the Brihanmumbai Electricity Supply and Transport (BEST) in Mumbai<sup>62</sup> in 2014.

Key data and assumptions were set as follows:

- **Total fleet** – The total projected fleet expected for 2018, accommodating the planned procurement of 12 additional buses was taken as the total fleet. Specifications of these new buses were, at the time of analysis, still to be determined by Sajha Yatayat. As a result, averages from the existing fleet were assumed to apply also to these anticipated vehicles. As such, the total fleet of 58 vehicles was used in this analysis.
- **Average fuel economy of diesel bus** – Mileage of the TATA and Ashok Leyland, under test conditions were observed to be above 3 km per liters. However, since the actual mileage is lower, a weighted average of the mileage of TATA and Ashok Leyland buses were taken. As such, a fuel

<sup>62</sup> Soni, A.R., Ballare, S., Chandel, M.K. 2014. Greenhouse gas mitigation potential of Mumbai's public transport system. Centre for Environmental

Science and Engineering, Indian Institute of Technology Bombay, Mumbai, India.

economy (mileage) of 2.8 kilometer per liter was used in this analysis.

- **Annual distance travelled of fleet** – Considering a total of 58 buses in the fleet, the total annual distance travelled by the fleet is taken as 2.5 million km.
- **Diesel emission factor** – The diesel emission factor used is 2.79 kg CO<sub>2</sub>eq per liter of diesel<sup>63</sup>.
- **Upstream and downstream emissions** – In addition, it is important to note that this analysis does not take into account upstream or downstream greenhouse gas emissions, for example associated with the manufacture of diesel versus electric buses. It considers only emissions due to fleet operations.

This analysis assumes that electricity powering electric buses in Kathmandu is sourced from hydropower stations within Nepal. Under this assumption, there are zero emissions associated with electric buses. However, if other emissions-intensive means of electricity production were adopted, the emissions reduction presented in Table 6.1 above would be void. Furthermore, the electricity being imported from India has a high carbon footprint as it is being generated from coal-based power plants. If vehicles are charged with this electricity, the emission reduction from electric buses would be lower. However, electricity import from India is estimated to decline as inhouse hydropower supply increases. With this, it can be safely assumed that emissions from electric vehicles will decline in the next couple of years.

Nonetheless, there is clearly a significant advantage to be had in switching to electric buses. With Nepal’s hydropower generation capacity expected to rise as new stations come online, there is significant scope for full adoption of electric.

### 6.3 Greenhouse Gas Emissions Results

Sajha Yatayat’s projected total fleet in 2018 is expected to emit 2,537 tons of CO<sub>2</sub> equivalent on an annual basis (12-month period). This is a quite significant amount within the context of Kathmandu.

**Table 6.1 Greenhouse Gas Emissions of Fleet**

	Greenhouse gas emissions (ton CO <sub>2</sub> eq)	
	Diesel	Electric
Whole fleet	2,537	0.0

Source: GGGI using data from US EPA (2015) and Sajha Yatayat

As Table 6.1 demonstrates, switching the electric for the entire fleet would result in a significant reduction in GHG emissions from traffic in Kathmandu.

<sup>63</sup> US Environment Protection Agency. 2015. Emission Factors for Greenhouse Gas Inventories. Center for Corporate Climate Leadership.

[https://www.epa.gov/sites/production/files/2015-11/documents/emission-factors\\_nov\\_2015.pdf](https://www.epa.gov/sites/production/files/2015-11/documents/emission-factors_nov_2015.pdf)

### 7.1 Introduction

A detailed analysis was undertaken to compare the maintenance, operational and socio-economic costs of diesel versus electric buses within the context of Kathmandu. This financial analysis is expected to support decision making around the feasibility of pursuing a broader program of electric mobility within Sajha Yatayat's operations. This lifetime cost analysis utilizes a range of perspectives, and explores costs associated both with the operation and maintenance of vehicles, as well as the health and environmental cost of diesel buses. In addition, the cost of the energy insecurity of diesel buses is also analyzed with specific reference to the tourism industry.

This analysis is structured by three essential parameters. Firstly, as identified in Chapter 5, the Lagankhel to Budhanilkantha Route (route 4), is the most ideal route upon which to deploy a pilot fleet of electric buses. The specifics of this route have been utilized in the following analysis. Secondly, the analysis was conducted for a single bus. This allows for direct diesel bus versus electric bus comparison, on a per unit basis. Thirdly, the time scale under consideration is the life of the bus, which for both electric and diesel buses is assumed to be ten years (see Section 7.2 below).

### 7.2 Data and Assumptions

Data for this analysis was collected from a variety of primary and secondary sources. Primary data included field research along the route, to collect specific details of trip times, passenger numbers, distance travelled and other data points. Primary data collected by Sajha Yatayat as part of its operational management was also utilized. Such data

included data on fuel economy, trip quantity, fuel consumption, fuel cost and other points. Finally, secondary data from a range of sources was also utilized, especially for data requirements around emissions factors for particulate matter and greenhouse gases, external health cost of air pollution, external health costs of noise pollution, cost of carbon and tourism related spending.

Key data points and assumptions are outlined below:

- **Life of bus** – The life of both diesel and electric vehicles was assumed to be ten years. This follows management and accounting practices within Sajha Yatayat, which set the life of existing vehicles at ten years. For the sake of ease of comparison, this was assumed to be the life of electric buses also. This is broadly in line with industry averages, which tend to range of 8-12 years.
- **Days of operation** – Buses on this route operate for an average of 29 days per month, some 345 days per year.
- **Annual distance travelled** – As it travels along the Lagankhel-Budhanilkantha route, a bus travels about 126.3 km on a daily basis. The average annual distance traveled by a bus on this route is estimated at 43,574 km.
- **Fuel economy of diesel bus** – The fuel economy of all these buses average to around 2.75 km per liter of diesel.
- **Energy efficiency of electric bus** – This was assumed to be 1.12 kWh/km. This is in line with a range of international reviews.
- **Annual fuel consumed** – The average annual diesel consumed by a bus, considering the average distance traveled, has been calculated as 15,845 liters.

### 7.3 Lifetime Costs

A major cost component is initial purchase of the vehicle, or acquisition cost. In Nepal, as in many countries, the price of an electric vehicle is much higher than an equivalent conventional ICE vehicle. In Nepal, conventional vehicles are subject to extremely high customs tax, amounting to nearly 250% of the value of the vehicle, while for electric vehicles it is only 10%. This massively favors electric vehicles. However, for both types of vehicle, if the vehicle is to be used for public transportation, a customs tax of only 1% is levied, effectively eliminating the fiscal advantage of going electric in this sector. Prices are specific to buses running on the nominated route.

Anticipated acquisition costs include:

- **Purchase price of diesel bus** – The price of an Ashok Leyland Viking diesel bus, delivered to Kathmandu is approx. NPR 3.19 million (USD 31,031) in 2016. This includes a 5% customs tax, 5% roads tax, 5% other taxes, 13% VAT and registration fee.

- **Purchase price of electric bus** – The price of an Ashok Leyland Circuit electric bus, delivered to Kathmandu is NPR 49 million (USD 480,000) in 2017. The price of a BYD K9 electric bus, delivered to Kathmandu is NPR 37 million (USD 369,000) in 2017. Given that no electric buses have been imported to Nepal yet, both these prices are indicative, and based on best estimation by the manufacturer in question. These prices are inclusive of the 1% import duty but do not include 13% VAT, as VAT is paid by the consumer and then later refunded. Electric buses are exempt of road taxes. In addition, the cost of charging is also included (cost of one charging infrastructure = USD 18,857<sup>64</sup>), on a one-to-one basis, as one charging facility is required per bus (for overnight charging).

In terms of operational and maintenance costs for diesel and electric buses, these are summarized in Table 7.2 below. The following discussion explores these cost components in more detail.

**Table 7.1 Final acquisition cost of diesel and electric buses**

Bus make and model	Fuel type	Indicative price (10 <sup>6</sup> NPR)**	Indicative price (thousand USD)***
Ashok Leyland - Viking	Diesel	3.19	29
BYD K7	Battery electric	23	225
BYD – K9*	Battery electric	31	298
Ashok Leyland – Circuit*	Battery electric	43	416

Source: GGGI. Data drawn from Sajha Yatayat, and through discussion with manufacturers.

\* For more information on these two proposed electric bus models please see Annex 2.

\*\*Does not include VAT as the operator is entitled to a VAT refund after purchasing the bus. \*\*\* USD 1 = NPR 102.8

**Table 7.2 Operational and maintenance costs over lifetime**

Cost component	Diesel	Electric	Delta
Lifetime fuel cost (NPR)	13,087,901	2,861,036	10,226,865
Lifetime maintenance cost (NPR)	6,576,587	3,288,293	3,288,293
<b>Total (NPR)</b>	<b>19,664,488</b>	<b>6,149,329</b>	<b>13,515,158</b>
<b>Total (USD)*</b>	<b>191,289</b>	<b>59,818</b>	<b>131,470</b>

Source: GGGI. Data drawn from Sajha Yatayat.

\*\*\* USD 1 = NPR 102.8

<sup>64</sup> Wang, N. Li, Y. Liu, Y. 2014. Economic Evaluation of Electric Bus Charging Infrastructure. 17<sup>th</sup> International Conference on Intelligent Transport Systems (ITSC). IEEE.

- **Cost of diesel** – Daily average operating cost for the eight buses plying on the Lagankhel-Budhanilkantha route in 2017 is just over NPR. 50,000 (USD 486), and daily operating cost for one bus is estimated as NPR 6,250 (USD 60). Fuel cost has the highest share (i.e. 41%) of the total operating cost of a diesel bus (see Figure 7.1). With this in mind, the average daily fuel cost per diesel bus was around NPR 22,000 (USD 214)<sup>65</sup>. In the analysis that follows, only fuel costs were compared (see Table 7.2.). Salary, administrative and other costs were assumed to be constant for both diesel and electric buses (see Figure 7.1). The current price of diesel is NPR 74 per liter (USD 0.72). Since the price of diesel has been lower than NPR 80 in the last two years, the price of diesel was assumed to increase from NPR 73 to NPR 78 during the 10-year life of an electric bus.
- **Cost of electricity** –Nepal Electricity Authority has set time-of-day (ToD) rates for electric vehicles which increases from NPR 3.7 per unit during the off-peak hour (23.00 hrs – 05.00 hrs) to NPR 5.6 per unit during the day time (05.00 hrs to 17.00 hrs) and NPR 7 per unit during the peak hour (17.00 hrs – 23.00 hrs) (NEA, 2017)<sup>66</sup>. A weighted average, assuming 80% of the vehicles are charged during off-peak hours and 10% each during the day and peak hour, was calculated to arrive at NPR 4.6

per unit (USD 0.04). This has been assumed to be constant for the 10-year life of an electric bus.

- **Maintenance cost of diesel bus** – Average annual maintenance cost for a single bus on this route was NPR 94,202 (USD 916.36) in 2013/14. This included both scheduled servicing and unscheduled maintenance and repairs. Maintenance spending has risen rapidly since 2013, when operations began: an average annual growth rate in spending of 106% is observable. However, this is considered unsustainable. Maintenance spending as a percentage of asset value (purchase price) is high in Kathmandu, at 9.6%. This is part due to the quality of roads, and high levels of congestion. For the purposes of this analysis, an annual average growth rate in maintenance spending of 40% was assumed.<sup>67</sup> This yields a total maintenance cost for a diesel bus of NPR 6,576,587 (USD 63,975) over the lifetime of the vehicle (see Table 7.2).
- **Maintenance cost of electric bus** – With far fewer moving parts, electric buses incur less maintenance and require fewer repairs. On average, the cost of maintaining an electric bus is considered to be around 50% of that of a diesel bus.<sup>68</sup> As such, the annual maintenance cost of an electric bus on the nominated route is projected to be around NPR 328,829 (USD 3,199).

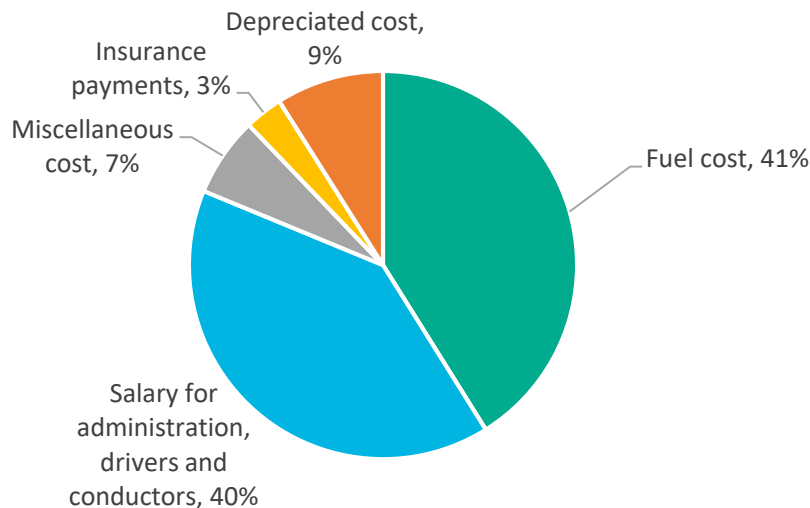

Source: Sajha Yatayat

**Figure 7.1 Breakdown of the operational cost of a diesel bus<sup>69</sup>**

<sup>65</sup> USD 1 = NPR 102.8

<sup>66</sup> Nepal Electricity Authority. 2017. Annual Report.

<sup>67</sup> Aber, J. 2016. Electric Bus Analysis for New York City Transit. Columbia University

<sup>68</sup> Aber, *Ibid.*

<sup>69</sup> The depreciation rate is 10%

## 7.4 Economic, Social and Environmental Costs

Beyond immediate operational costs, diesel buses also generate health costs as a result of air and noise pollution and environmental costs as a result of the emissions of carbon. In addition, given Nepal's total dependence on foreign sources of oil, exacerbated by the fact that the country is landlocked, and therefore unable to directly import oil (due to the absence of a sea port), a reliance on diesel buses generates energy insecurity. This also has a cost. Below, these costs are explored in turn.

As for operational costs outlined above, the analysis of economic, social and environmental costs below was undertaken over a projected ten-year lifetime of a bus.

### 7.4.1 Economic cost of energy insecurity

Nepal imports 100% of its fuel from India. Any fuel supply disruptions have significant negative impact on the economy. An example of such a case is the five-month long fuel supply disruption that occurred at the southern border of Nepal during 2015/2016<sup>70</sup>. This disruption caused severe fossil fuel shortages in Kathmandu, and Nepal more generally, which in turn severely affected services in the transport sector. With a drop in transport options, as well as disturbances due to the 2015 earthquakes, the number of tourists declined by 32% in 2015, compared to that in 2014. As a result, almost NPR 5 billion was lost due to decrease in tourist arrivals during 2015.

Tourism is one sector that has made significant contributions to Nepal's economy in recent years. The World Travel and Tourism Council (WTWC)<sup>71</sup> estimated that tourism contributed to almost 4.3% and 4.0% of the country's GDP in 2014 and 2016, respectively. The number of tourists have been observed to grow with increasing quality of facilities provided by the service sector. In addition to hotels, travel agencies and airlines, a reliable transport sector also plays a significant role in encouraging tourists to plan a trip to the country. As such, with reference to the fossil fuel supply disruption of 2015/2016, this study analyzes the economic benefits of tourism in

Nepal due to stable electric transport services. Such services, by being electric, would be impervious to fossil fuel supply disruptions.<sup>72</sup> Such a disruption was assumed to take place on average once every 10 years. Specifically, the introduction of electric buses in the public transport sector in Kathmandu would lead to increased energy security and as a result, provide sustained benefits to the economy.

Specifically, this analysis accepted that fossil fuel supply disruptions and other disturbances would reduce tourist numbers, but that 20% of tourists (some 17,100 visitors) would still visit Kathmandu if the metropolitan area was serviced by electric buses, making travel around the city fluent. From data drawn across 2014-2016, a typical tourist spends an average of 12.44 days in Nepal, and NPR 4410 (USD 44) per day<sup>73</sup>. As such, with 17,100 visitors still making the trip to Kathmandu, supported by electric bus transport services, total spending that would accrue to the economy amounts to NPR 938,112,840 (USD 9 million). To support these tourists, 90 electric buses would be required in daily service, making a per bus contribution to the economy of NPR 10,393,303 (USD 101,102).

### 7.4.2 Social cost of air and noise pollution

Air and noise pollution from a diesel bus are significantly higher compared to an electric bus. The analysis considers both components below.

In terms of air, air quality in Kathmandu has been observed to be at alarming levels in the past few years. Several causes have been identified for this increase in air pollution levels in the valley, out of which rapid motorization and ineffective management of public transport systems have been identified to contribute significantly to the degrading air quality. Fossil fuel vehicles are the main causes of high levels of PM emissions within the country. Beuker's et al. (2014)<sup>74</sup> state that 100% of the external costs of PM are related to health effects. PM emissions can chronically sicken or even kill significantly more people than other pollutants that come out of the exhaust of fossil fuel vehicles<sup>75</sup>. Sengupta and Mandal (2002)<sup>76</sup> emphasize that numerous studies have outlined that as the size of particles become smaller, their effect becomes more lethal. In addition, health costs associated with one kg of PM

<sup>70</sup> Nepal Economic Forum. 2016. Post Disaster Assessment Blockade 2015/2016. Alliance for Social Dialogue

<sup>71</sup> World Travel and Tourism Council. 2017. <https://www.wttc.org/research/economic-research/economic-impact-analysis/country-reports/>

<sup>72</sup> This analysis is carried out with the assumption that major disruptions in fuel supply may occur once every decade

<sup>73</sup> World Travel and Tourism Council. 2017. <https://www.wttc.org/research/economic-research/economic-impact-analysis/country-reports/>

<sup>74</sup> Buekers, J., Holderbeke, M.V., Blerkens, J.G.E.A., Panis L. 2014. Health and environmental benefits related to electric vehicle introduction in EU countries. Transportation research Part D Transport and Environment.

<sup>75</sup> Sen, A.K., Tiwari, G., Upadhyay, V. 2010. Estimating marginal external costs of transport in Delhi. *Transport Policy*; 17:27-37.

<sup>76</sup> Sengupta, R.P., Mandal, S., 2002. Health Damage Cost of Automotive Air Pollution: Cost-Benefit Analysis of Fuel Quality Upgradation for Indian Cities. Research Study for National Institute of Public Finance & Policy, New Delhi.

emissions in Delhi, India was used to calculate health costs in Nepal. This health costs are estimates of lost work days, restricted activity, tolerating certain symptoms of illness, value of life, etc.<sup>77</sup>. This cost in Nepal was then multiplied with the total PM emissions from a single diesel bus to arrive at an overall value that reflected health costs due to PM emissions from a bus<sup>78</sup>. Since there are zero PM emissions from electric buses, this health cost will be saved if a diesel bus is replaced by an electric bus. The cost of PM emissions on health is estimated to be NPR 4,611,619 (USD44,860) during the 10-year life of an electric bus.

In terms of noise, noise pollution from transport also has a high negative impact on health. At low speeds (i.e., 20 -25 mph, approx. 32 – 40 kph), the difference in noise levels between an electric bus and a diesel bus is substantial. This high level of noise from diesel buses can cause acute myocardial infraction, stroke, dementia and annoyance. Government of UK (2013)<sup>79</sup> has estimated cost per household of a single decibel increase in noise levels from road transport. From this data, the cost of change in noise levels from 30 db to 77 db was estimated. This value was then adapted to conditions in the Lagankhel – Budhanilkantha route in Kathmandu. Total savings from decrease in noise levels from 77 db to 30 db when switched to an electric bus is NPR. 7,721,415 (USD 75,111).

The total social cost due to air and noise pollution, as indicated above, is around NPR 11,723,683 (USD 114,043) over the lifetime of a diesel bus.

### 7.4.3 Environmental cost of carbon

The emission of greenhouse gas, as explored in Chapter 6, shows that the total fleet of Sajha Yatayat is estimated to have a significant amount of annual emissions, which has high environmental cost. A carbon tax is typically introduced to internalize the external costs of carbon emitted in different sectors, including the transport sector.

Carbon tax plays a significant role in regulating GHG emissions from different energy intensive sectors around the world. There are numerous advantages to introducing carbon tax, which include encouraging alternative and more efficient energy systems, raising revenue and leading to socially efficient outcomes. In case of Nepal, there are no carbon taxes being levied on emissions in any of the sectors yet. The carbon tax benefit is estimated with the

assumption that a global carbon tax exists where Nepal can trade. Also, it has been assumed that the value of carbon tax may increase in the 10-year life of an electric bus. Thus, in this study, the carbon tax levied on emissions from the transport sector has been assumed to increase from USD 40 per ton in year 1 to USD 80 per ton in year 10 as most countries around the world imposed carbon taxes in this range.

Since there are no tail-pipe emissions from electric buses, the study shows that replacing a single diesel bus by an electric bus will incur savings of NPR 3,338,927 (USD 32,479) during the 10-year life of the bus.

## 7.5 Summary of Total Lifetime Cost Analysis

Based on the above analyses, the cumulative lifetime costs of electric buses can be compared to the cumulative lifetime costs of diesel buses. The results favor BYD's K7, at 39% lower cost than diesel.

Although the acquisition cost of diesel buses is significantly lower when compared to electric buses, its social, economic, environmental, along with operation and maintenance costs outweigh the total cost of electric buses (see Figure 7.2). Tables 7.3 and 7.4 below summarize these results for each of the proposed bus types

As Figure 7.2 clearly demonstrates, the electric bus options are significantly cheaper over the total lifetime of the vehicle, accounting for all mayor direct and indirect costs. The costs of diesel buses, to the operator and to society, the environment and the economy, far exceed the costs of electric buses. As such, although the acquisition cost of diesel buses is significantly lower when compared to electric buses, its social, economic, environmental, along with operation and maintenance costs make it an inferior choice. Of the electric bus options, the BDY K7 bus is almost half the cost of the current diesel buses deployed by Sajha Yatayat. These cost differentials are explored in Tables 7.3, Table 7.4 and Table 7.5 below.

<sup>77</sup> Delucchi, M.A., 2000. Environmental externalities of Motor Vehicles Use in the US. *Journal of Transport Economics & Policy* 34 (2), 135–168

<sup>78</sup> Note: PM emission factor was adopted from a study by Bajracharya and Bhattarai, 2016. <http://media-energy.com.np/wp-content/uploads/2016/05/iswor-Bajcharye.pdf>

<sup>79</sup> Government of UK. Study Available at <https://www.gov.uk/noise-pollution-economic-analysis>. 2013.

**Table 7.3 Summary of costs electric (K7) vs. diesel bus**

Cost component	Cost (NPR)		
	Diesel (Viking)	Electric (K7)**	Delta
Acquisition cost***	3,198,345	23,104,100	-19,905,755
Lifetime fuel cost	13,087,901	2,861,036	10,226,865
Lifetime maintenance cost	6,576,587	3,288,293	3,288,293
Economic cost	10,393,303	-	10,393,303
Social cost	11,723,683	-	11,723,683
Environmental cost	3,338,927	-	3,338,927
<b>Total (NPR)</b>	<b>48,318,746</b>	<b>29,253,429</b>	<b>19,065,317</b>
<b>Total (USD)*</b>	<b>470,027</b>	<b>284,566</b>	<b>185,460</b>

Source: GGGI.

\*USD 1 = NPR 102.8. \*\* '-' here denotes a negligible value.

\*\*\* Acquisition cost is exclusive of VAT as the operator is eligible for a VAT refund after purchase of the electric bus

**Table 7.4 Summary of costs electric (K9) vs. diesel bus**

Cost component	Cost (NPR)		
	Diesel (Viking)	Electric (K9)**	Delta
Acquisition cost***	3,198,345	30,618,500	-27,420,155
Lifetime fuel cost	13,087,901	2,861,036	10,226,865
Lifetime maintenance cost	6,576,587	3,288,293	3,288,293
Economic cost	10,393,303	-	10,393,303
Social cost	11,723,683	-	11,723,683
Environmental cost	3,338,927	-	3,338,927
<b>Total (NPR)</b>	<b>48,318,746</b>	<b>36,767,829</b>	<b>11,550,917</b>
<b>Total (USD)*</b>	<b>470,027</b>	<b>357,664</b>	<b>112,363</b>

Source: GGGI.

\*USD 1 = NPR 102.8. \*\* '-' here denotes a negligible value

\*\*\* Acquisition cost is exclusive of VAT as the operator is eligible for a VAT refund after purchase of the electric bus

**Table 7.5 Summary of costs electric (Circuit) vs. diesel bus**

Cost component	Cost (NPR)		
	Diesel (Viking)	Electric (Circuit)**	Delta
Acquisition cost***	3,198,345	42,738,500	-39,540,155
Annual fuel cost	13,087,901	2,861,036	10,226,865
Annual maintenance cost	6,576,587	3,288,293	3,288,293
Economic cost	10,393,303	-	10,393,303
Social cost	11,723,683	-	11,723,683
Environmental cost	3,338,927	-	3,338,927
<b>Total (NPR)</b>	<b>48,318,746</b>	<b>58,887,829</b>	<b>-569,083</b>
<b>Total (USD)*</b>	<b>470,027</b>	<b>475,563</b>	<b>-5,536</b>

Source: GGGI.

\*USD 1 = NPR 102.8. \*\* '-' here denotes a negligible value

\*\*\* Acquisition cost is exclusive of VAT as the operator is eligible for a VAT refund after purchase of the electric bus



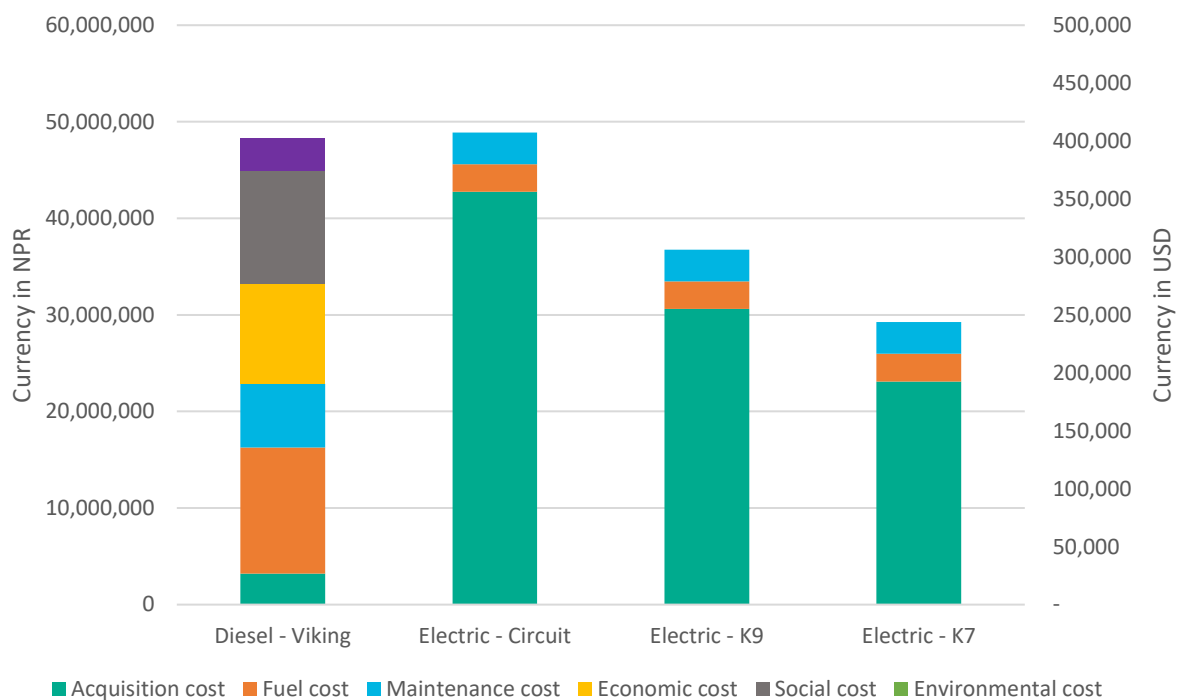

Source: GGGI

**Figure 7.2 Summary of costs electric buses vs. diesel bus (NPR and USD)**

This chapter has valued the major direct and indirect costs of electric buses versus diesel buses and found electric buses to be significantly superior when a total cost of ownership approach is taken. However, there are additional benefits to electric buses which have not been accounted for here, due to limitations in current valuation methods. As a result, the superiority of electric buses will be even higher. For example, a major benefit which was not valued is the strategic long-term value of the electric bus

pilot initiative. The initiative has tremendous transformative potential; it has the potential to trigger an electric vehicle revolution in Nepal. Countries all over the world have adopted various strategies to shift into electric mobility. This initiative will provide an appropriate platform for Sajha Yatayat and other public vehicle operators, along with funding agencies, to realize the viability and benefits of electric buses and electric mobility in Nepal.



MARIE STOPES  
NEPAL

सुदूरपश्चिम प्रदेश सरकार  
सुदूरपश्चिम प्रदेश स्वास्थ्य विभाग  
सुदूरपश्चिम प्रदेश स्वास्थ्य विभाग  
सुदूरपश्चिम प्रदेश स्वास्थ्य विभाग

## Chapter 8

# OPTIONS FOR LOCAL MANUFACTURING

### 8.1. Introduction

Given Nepal's electricity production potential (see Box 6.1), the high economic cost of energy insecurity resulting from total dependence on foreign sources of oil, and the high social and environmental costs of continuing to deploy diesel buses in Nepal, systematic replacement of all forms of diesel and petrol vehicles by electric vehicles should be a long-term goal for the country. To support this, Nepal has the option of strengthening its already existing electric vehicle manufacturing base, with the objective of locally producing electric buses, including minibuses, minibuses and midi-buses. Under the Environment Friendly Transport Policy, 2015, there is provision for local manufacturing<sup>80</sup>. As such, at the highest level, there is government support for the concept. While additional policy, regulatory and institutional refinement and work is necessary (see Section 7.6 below), there is clear scope for the possibility of development.

This chapter explores this possibility. It does this by reviewing previous experiences with electric vehicle production in Nepal, before exploring a tentative process and the proposed requirements of producing electric vehicles in Nepal. The cost of producing a 9-meter, 20 seater midi-bus is detailed. In addition, supporting and enabling conditions for such local production are set out. This chapter was compiled with the support of consultations electric vehicle operators and investors.

---

<sup>80</sup> Ministry of Physical Infrastructure and Transport. 2015. Environmentally Friendly Transport Policy 2015. Government of Nepal. <http://www.mopit.gov.np/uploads/files/policies&directives/Watawaranmaitri%20Sawari%20tatha%20Yatayat%20Niti%202071.pdf>.

### 8.2. Review of Electric Vehicle Manufacturing in Nepal

There are two examples of electric vehicle manufacturing in Nepal. The first involved the local assembly of electric three-wheelers in Kathmandu during 1993-2011. This small industry saw the production of 721 electric vehicles during this period. The industry was initiated by Global Resources Institute, as an electric vehicle program in Kathmandu during 1993-1996. The initiative produced a fleet of eight electric three-wheelers or *safa tempos*, as they are locally known. On the strength of this, and recognizing the business opportunity of local production, five manufacturers namely, Nepal Electric Vehicle Industry, Electric Vehicle Company, Green Electric Vehicle, Green Valley and Bagmati Electricals produced a total of 714 *safa tempos* from 1996-2011, an average of 47 a year. Most of these *safa tempos* are still deployed on the streets of Kathmandu.<sup>81</sup>

The initial pilot of eight vehicles involved importing all parts required to produce the electric three-wheelers. However, in 2000, four years of private sector manufacturing began, local industry began manufacturing the required parts for the *safa tempos*, increasing production of vehicles and holding down cost. As a result, in 2011, the central government moved to restrict three-wheeler registration, citing issues of congestion on the smaller tertiary routes that *safa tempos* tend to ply. Since 2011, the total number of registered *safa tempos* in Nepal has remained fixed at 714. In this way, the industry, was a victim of its own

<sup>81</sup> Global Resources Institute. 2006. Electric Vehicles in Kathmandu. Global Resources institute (GRI). <http://www.grilink.org/ktm.htm>

success. Initially parts were imported, however, the process evolved to include local production of parts for assembly.

The second experience is more recent, involving electric two-wheelers and rickshaws. Tailg is a Chinese company, producing electric scooters and electric bicycles in China for both domestic and international sale. The company is expanding heavily and is seeking to increase international production and sales of its products.<sup>82</sup> As part of this, Tailg Nepal has established an assembly unit in Gothatar, on the outskirts of Kathmandu. As of October 2017, the company has assembled and sold 22 electric rickshaws and is still in the process of an assembly system for electric scooters.<sup>83</sup>

Both these examples demonstrate scope for development of the local electric vehicle manufacturing industry. In the case of electric buses, the scope for development is both a function of financing and government policy, as well as local demand.

### 8.3. Estimated Demand for Electric Buses

There has been no research into the size of the demand for electric buses in Nepal. However, this report assumes that national demand for diesel buses is a viable proxy or indicator of national demand for electric buses. This assumption is consistent with the overall logic of this report and analysis, which is that electric buses are feasible, indeed preferable, replacements to diesel buses. As such, trade and customs data showing import numbers for diesel buses are presented below.

Using data from 1990 – 2017, the total number of diesel buses of all categories operating in Nepal is growing at an annual rate of 10%, as showing in Figure 8.1. This gives an average import volume of some 1655 units per year. Driving this trend is overall population growth and socioeconomic development, as well as urbanization, which generates demand for commuter (intra-city) public transport, and tourism growth, generating inter-city bus transport demand.

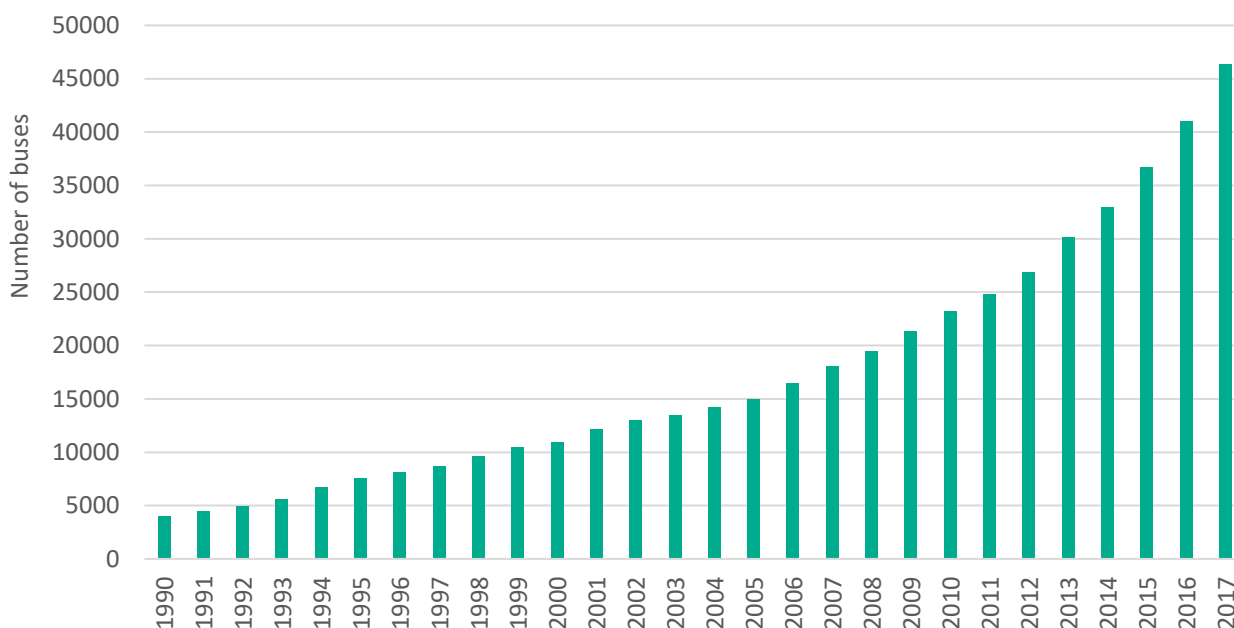

Source: Department of Transport Management, 2017<sup>84</sup>

**Figure 8.1. Number of registered buses in Nepal (cumulative) (1990 – 2017)**

<sup>82</sup> China Daily. 2017. "TAILG plugs right into Belt and Road opportunities", in China Daily. Accessed at [http://usa.chinadaily.com.cn/epaper/2017-05/09/content\\_29267407.htm](http://usa.chinadaily.com.cn/epaper/2017-05/09/content_29267407.htm)

<sup>83</sup> Following phone interviews with Tailg Nepal representatives undertaken by GGGI

<sup>84</sup> DoTM. 2017. Vehicle Registration Data. Department of Transport Management.

Nepal imports several categories of bus, including minibuses, minibuses, midi-buses and full-size buses. On average, demand is broken across these categories according to Table 8.1 below.

**Table 8.1 Annual demand per category of bus**

Bus category	Average annual demand (%)	Average annual demand (units)
Full-size bus/midi-bus	57	1655
Minibus/Minitruck	29	844
Microbus	13	382
<b>TOTAL</b>	<b>100</b>	<b>2881</b>

Source: DoTM, 2017<sup>85</sup>

In 2014, 26% of all buses in Nepal were operating in Kathmandu, accounting for some nearly 12,000 vehicles. The rest are primarily operating in the other metropolitan cities of the country.

## 8.4. Estimated Local Manufacturing Process and Requirements

### 8.4.1 Unit Summary and Assembly Process

The process and requirements for local assembly described below are designed to produce a functional electric midi-bus as minimum cost, suitable to the conditions and requirements of Kathmandu, and Nepal more generally. An overview of this proposed midi-bus is made in Table 8.2 below.

Similar to the model deployed in the initial production of electric two-wheelers in Kathmandu, the proposed process for producing electric buses would rely upon the import of parts. The Kathmandu-based operation would involve assembly of these parts. This process is elaborated in Figure 8.2 below. Parts for import would include:

- Chassis
- Battery
- Metal components, such as the motor, controller, battery box and controller
- Electronics, including radio, wiring, lights and light controllers
- Rubber works, including tires, rubber trim and grommets

- Glass components, such as windshield and windows
- Mechanical components,
- Plastics, such as front and rear bumper, fascia, seats, trim
- Fluid components, such as lubricants, brake fluid

**Table 8.2. Summary of bus specifications**

Type of bus produced	Midi-bus
Overall dimensions	5 × 1.3 × 2 meters
Capacity range	20 seating, 10 standing
Estimated drive range	100 km
Max. gradient capacity (loaded)	20%
Other specifications	Non-AC
Production strategy	Assembly of imported parts
Estimated cost of assembly per unit (NPR)	0.9 – 1.5 million
Estimated retail price per unit (NPR)	1.8 - 3.0 million
Estimated production time per unit	1 week

Source: GGGI and EVAN

The time required for sourcing and delivery of all required parts to Kathmandu is likely to be some months. However, upon delivery, approximately one week would be required to assemble the parts into the finished bus.

### 8.4.2 Resources and Capital Investment Required

In addition, the process and parts described above, land, equipment, human resources, plant facilities, and a range of other resources would be required. The resource requirements outlined below are designed with the objective of producing some 20 units of midi-bus per month.

<sup>85</sup> DoTM. 2017. Vehicle Registration Data. Department of Transport Management.

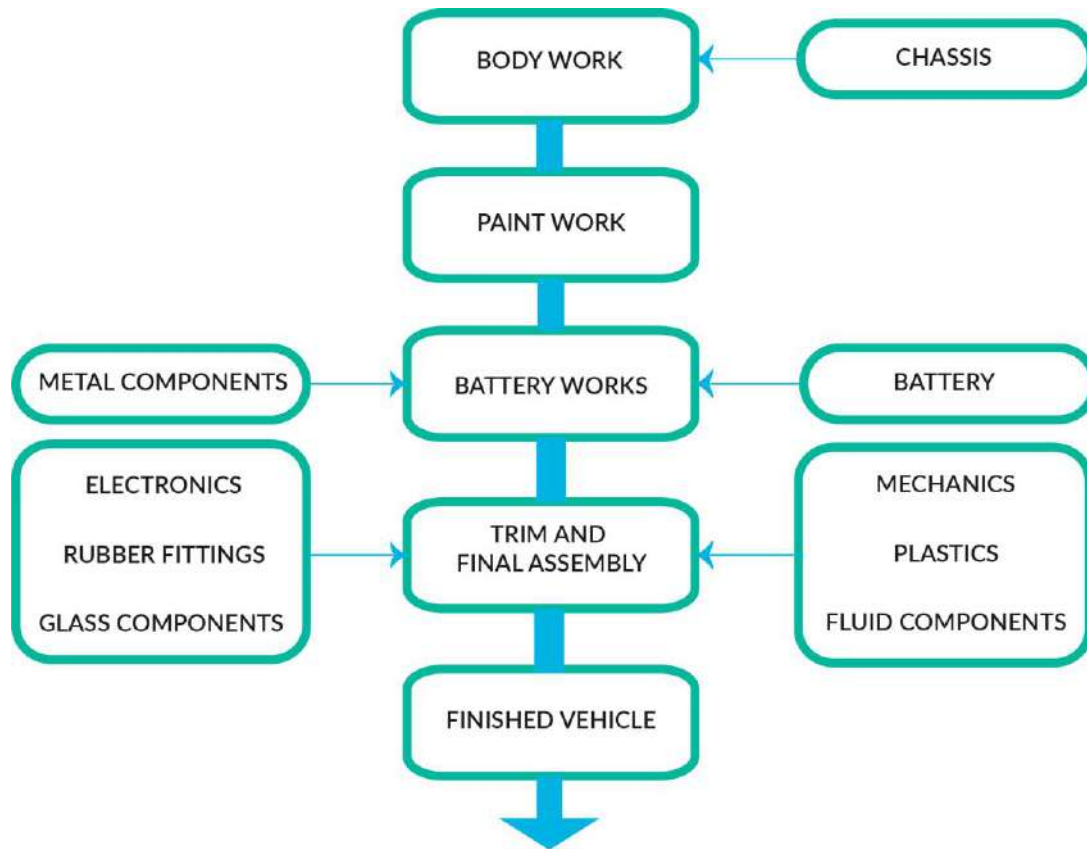

Source: Adapted from Global Asset Protection Services, 2015<sup>86</sup>

**Figure 8.2. Proposed assembly process**

Requirements include:

- **Land requirements** – Total land required to establish a viable assembly unit is estimated at 2500 square meters (some 5 ropani). Facilities would include steel and body works facility, trim and final assembly garage, charging station, and offices.
- **Equipment requirements** – A range of tools and equipment would be required including general tools; grinder, drill and cutting tools; tools used for air brakes; welding machines; hydraulic machines.
- **Human resource requirements** – A total of 22 staff would be expected to operate and manage the assembly unit. These include a draft-person, electrical technicians and engineers, mechanical engineers and assistants, procurement officer, maintenance technician, quality control officer, lathe and milling machine operators, and cleaners.

Overall, the total capital investment is expected to be around NPR 70 million (USD 670,000). Land, the most-costly

component, is expected to be located outside of Kathmandu Valley.

**Table 8.3. Summary of investment (million NPR)**

Component	Cost
Land	56
Construction of facilities	12
Tools and machinery	3.5
<b>Total (million NPR)</b>	<b>71.5</b>
<b>Total (USD)*</b>	<b>695,525</b>

Source: EVAN

\*USD 1 = NPR 102.8

### 8.4.3 Per Unit Assembly Cost and Retail Price

The estimated per unit cost of assembly ranges from NPR 0.9 - 1.5 million (USD 8600 – 14500) depending on the size of the battery being used (see Table 8.4.). The battery constitutes around 50-60 % of the manufacturing cost, which is followed by 20-40% body design cost, 10% controller, 5% motor, 5% transmission and 5% other costs. Table 8.5 shows the breakdown of the retail price of a bus.

<sup>86</sup> Global Asset Protection Services LLC. 2015. Vehicle Manufacturing.

**Table 8.4 Breakdown of per unit assembly cost (NPR)**

Component	Lower end of range	Higher end of range
Battery	495,000	825,000
Controllers	90,000	150,000
Motor	45,000	75,000
Transmission	45,000	75,000
Body Design	180,000	300,000
Other	45,000	75,000
<b>Total (NPR)</b>	<b>900,000</b>	<b>1,500,000</b>
<b>Total (USD)</b>	<b>8,754</b>	<b>14,591</b>

Source: JMBS, 2012; Cuenca et.al. 1999

\*USD 1 = NPR 102.8

**Table 8.5 Breakdown of per unit retail price (NPR)**

Component	Lower end of range	Higher end of range
Manufacturer	900,000	1,500,000
Warranty	90,000	150,000
Selling & Admin	360,000	600,000
Overhead	270,000	450,000
Profit Margin	180,000	300,000
<b>Total (NPR)</b>	<b>1,800,000</b>	<b>3,000,000</b>
<b>Total (USD)</b>	<b>17,509</b>	<b>29,182</b>

Source: JMBS, 2012; Cuenca et.al. 1999

\*USD 1 = NPR 102.8

## 8.5. Direct Benefits of Local Manufacturing

The development of such an assembly unit, and the longer-term goal of systematic manufacture of required parts for electric buses would deliver a range of immediate and direct benefits, such as the availability of cheaper electric buses and improved vehicle servicing. In addition, strategic benefits of increased industrial independence and economic development. This does not include indirect benefits resulting from the wider-spread uptake of electric vehicles across Nepal, such as improved public health and reduced carbon emissions.

Direct benefits of local manufacturing include:

- **Increased affordability** – The use of local resources, such as labor and raw materials, will reduce the cost of production, making electric buses more financially attractive.

- **Generation of local employment** – Local manufacturing plants will generate employment. This will not only provide opportunities for skills development in manufacturing but also provide livelihoods to both skilled and unskilled workers.
- **Increased industrial independence** – Currently, the majority of viable electric vehicles available on the Nepali market, including electric buses, have been imported from India and China. Local manufacturing will decrease reliance on other countries for electric vehicles.
- **Increased scope for customization** – With local manufacturing, there are increased options for local customization at affordable prices, as well as increased availability of spare parts.
- **Improved after-sales vehicle servicing** – Local manufacturing units will have expertise as well as spare parts available to service the local produced vehicles. This means the consumer and bus operator receives improved servicing, potentially at a lower cost.
- **Increased economic development** – A stronger local manufacturing industry will contribute to the economic development of the Kathmandu Valley, and Nepal more generally. With a national goal of becoming a middle-income country by 2030, the establishment of local manufacturing units could be valuable.
- **Reduced trade deficit long-term** - The gap between import and export in Nepal has continuously widened during the last two decades<sup>87</sup>. Local manufacturing plants can help in reducing that gap.

## 8.6. Action for Local Manufacturing

To support local manufacturing, various actions from government, civil society and the business community are needed. Increasingly, as Chapter 5 explored, there is a favorable and robust policy and regulatory environment for electric vehicles. However, additional action could be taken to improve the scope of local electric vehicle manufacturing more specifically. These actions are outlined below:

- **Building public-private consensus for local manufacturing** – Greater collaboration and consensus amongst relevant government bodies and the business community on the need, benefits and necessary steps to boost local manufacturing

<sup>87</sup> Ghimire, L.S. 2016. Nepal's Widening Trade Deficit (Some Issues, Challenges and Recommendations). Economic Management Division: Staff Discussion Paper. Nepal Planning Commission.

is critical. This can be achieved through greater dialogue, and high-level discussions, as well as formalized through private-public commissions.

- **Refining the fiscal landscape** – Steps in the right direction to improve the fiscal attractiveness of shifting towards electric vehicles. These were highlighted in Chapter 5. However, with specific reference to local manufacturing, more can be done. Specifically, spare parts for the assembly of electric vehicles are levied with a customs duty which could be exempted.
- **Improving the non-fiscal regulation** – Prioritized registration of locally produced electric buses, for example, as well as preferential electric tariffs, would greatly support local manufacturing companies in promoting their products, as well as support consumers through reduced operational costs.
- **Establishing quality standards for locally produced electric buses** – Currently, there is no institution or body tasked with ensuring the quality of locally produced electric vehicles of any type. The establishment of such a body would facilitate consumer trust by a) setting clear standards to manufacturers; and b) monitoring and verifying that manufacturers are in compliance with standards set.
- **Establishing a shared procurement channel** – A consortium of manufacturers could jointly procure batteries and other parts required for the assembly of electric buses. Such a shared procurement channel would reduce costs to local manufacturers, and ultimately the consumer. This will also help to boost competition in terms of assembly and retail cost.
- **Establishing a battery recycling plant** – With batteries constituting such a large share of the overall assembly cost of an electric vehicle, a battery recycling facility could help to extend the life of batteries and provide recycled batteries for use in assembly chains, as well as minimize waste. Customs duty on equipment required for battery recycling already receives a preferential low rate of 1%, however, a recycling plant has yet to be established.



### 9.1 Electric Buses are Viable

This study has demonstrated the viability of deploying electric buses in Kathmandu. Such deployment is feasible from policy, operational and financial perspectives. As such, Sajha Yatayat is in a strong position to shift towards deploying electric buses within its current fleet.

Additionally, the financial viability of electric buses is expected to increase as the technology becomes cheaper, and production systems mature. However, this is not an argument for waiting. Even at current market prices, it is cheaper for Sajha Yatayat to deploy electric buses than diesel buses, when major associated costs are internalized. More broadly, it is cheaper for the society and economy of Kathmandu, and those institutions that represent the public interest, to deploy electric buses when compared against diesel.

### 9.2 Summary of Key Findings

A summary of the key findings is presented below:

- **Technology is increasingly ready and available** – While this report focuses on two most-viable vendors, namely BYD and Ashok Leyland, other manufacturers also represent solid options. More generally, the technology behind electric buses is becoming more widespread, generating important economies of scale. As markets grow and production systems mature, the per unit cost of electric bus reduces.
- **Supportive policy, regulation and politics is in place** – A robust policy and regulatory framework exists already and is widely supportive of electric

vehicles and sustainable technology. Such support ranges from the policy and planning level, through to specific fiscal incentives. In addition, air quality in metropolitan Nepal has become an important political issue, with local and national politicians recognizing and capitalizing on it with promises of measures for air quality improvements. As such, while there is certainly scope for further improvement of policy and regulation, and further techno-political discussion on the topic, sufficient progress has been made within this space to ensure that deployment of electric vehicles by Sajha Yatayat will be viewed favorably by government.

- **Supportive public is in place** – Similarly, the general public and commuters on Sajha Yatayat's current services view electric buses favorably. During field discussions with both segments, the trolley buses of the 1970s-2000s were consistently praised. Most members of the public recognize the need for zero- or low-emissions vehicles. As such, there is an already existing very positive public image associated with electric buses in Kathmandu. This public image meshes well with Sajha Yatayat's current image. If Sajha Yatayat more assertively adopts electric buses, the organization would benefit from a boost in public image accordingly, and effectively capture some of the goodwill held by the public for the trolley buses.
- **Sajha Yatayat's cross-city routes are well suited for electric** – Working across several cross-city routes, Sajha Yatayat's set-up is well suited for electric buses. The Lagankhel-Budhanilkantha route is especially well suited. This 17-kilometer route follows a reasonable gradient on decent

roads, is well populated, and receives steady ridership at above 4000 passengers per day. Total distance travelled daily, some 125 kilometers, is such that most standard electric transit buses can deliver the required drive-range.

- **Greenhouse gas emissions mitigation potential of electric is considerable** - If Sajha Yatayat were to replace its total projected 2018 fleet of 58 buses by electric buses, the annual reduction in GHG emissions would be 2,537 tons of CO<sub>2e</sub>. Per bus annual emissions savings would be 43 tons of CO<sub>2e</sub>. This quantity of savings contributes to reducing GHG emissions from the transport sector, as well as reducing air and noise pollution.
- **Switching to electric brings lifetime financial advantages** – While the initial upfront price of an electric bus is higher than that of a diesel bus, over its total lifetime, electric buses are cheaper by some 24-39%. Total costs to be considered include the acquisition cost of the vehicle (i.e. its price), and the higher operational (fuel) and maintenance costs of diesel. The operation and maintenance costs of an electric bus is over 60% lower than that of a diesel bus. Similarly, there are higher economic, social and environmental costs associated with diesel. The energy insecurity of diesel costs the economy around NPR 13,087,901 (USD 273,394) over the lifetime of the single bus. Healthcare and productivity costs associated with air and noise pollution cost society around NPR 11,723,683 (USD 101,102) per diesel bus over its lifetime. And the carbon emitted by a diesel bus over its lifetime costs the environment around NPR 3,338,927 (USD 32,479). All these costs add up, to make electric buses 24-39% cheaper than diesel over the life of the vehicle.
- **BYD's K7 electric bus is the cheapest lifetime option, cheaper than current diesel** – Of course, the cost and performance of electric buses vary. Of the two main manufacturers expressing interest in delivering electric buses to market in Kathmandu, namely BYD and Ashok Leyland, the results of the BYD K7 bus was superior. It was some 40 per cent cheaper, overall, when compared with the Ashok Leyland electric bus, and it had a better drive range and included AC.
- **Local manufacturing of electric buses is financially feasible** - Establishing electric bus manufacturing facilities in Nepal is an option that can substantially decrease acquisition cost of electric buses, increase access to spare parts, facilitate localized vehicle customization, stimulate the economy and decrease trade deficits. Moving

ahead with local manufacturing requires both government and private sector action. Namely, commitment of electric bus demand (market) from bus and transit operators, and commitment of resources for production from the government and private sector.

### 9.3 Recommendations and Next Steps

As a result of the findings outlined above, this report recommends that:

#### In terms of operation:

- Sajha Yatayat initiate a process of procurement of a micro-fleet of electric buses (some five units), through which cheaper prices for the electric models identified may be obtained.
- Sajha Yatayat consider securing dedicated charging facility space within its terminal stations or within its central bus depot, depending on the final charging strategy pursued.
- Sajha Yatayat consider investing in training of its existing engineers and technicians to service electric buses.
- Sajha Yatayat initiate discussions with the Nepal Electricity Authority on the possibility of collaboration for low-tariff charging.
- Sajha Yatayat, upon deploying electric buses in its fleet, maintain datasets specific to the electric buses to ensure adequate monitoring and benefit optimization.

#### In terms of financing:

- Sajha Yatayat, the Ministry of Finance and the Ministry of Population and Environment, explore methods or strategies by which financing from the national pollution fund might be mobilized to support increased electric bus acquisition.
- Sajha Yatayat and the Kathmandu Municipal Corporation, explore the possibility of apply for financing by the Town Development Fund.
- Sajha Yatayat, the Ministry of Physical Infrastructure and Transport, the Kathmandu Municipal Corporation, and GGGI, explore financing opportunities with international donors, including green and climate financing sources.

#### In terms of manufacturing:

- The Department of Transport Management consider active support for local manufacturing of electric buses.
- Sajha Yatayat, in collaboration with private sector, explore committing to demand for electric buses, to support investment in manufacturing facilities



बाहिर

न्यूरोड गेट-रत्नपार्क

पुरानो बसपार्क-शहिदगेट

त्रिपुरेश्वर-माईतिघर

नयां बानेश्वर-तिनकु

साझा यातायात

Kappa



SA

YA

## References

- Aber, J. 2016. Electric Bus Analysis for New York City Transit. Columbia University.
- Asian Development Bank. 2013. Sector Assessment (Summary): Transport and Information and Communication Technology. Country Partnership Strategy.
- ADB. 2016. Transport Sector Assessment: Country Partnership Strategy.
- Bajracharya and Bhattarai. 2016. 'Road Transportation Energy Demand and Environmental Emission: A Case of Kathmandu Valley' in Hydro Nepal, no. 18, January 2016 p. 30-40.
- Buekers, J., Holderbeke, M.V., Blerkens, J.G.E.A., Panis L. 2014. Health and environmental benefits related to electric vehicle introduction in EU countries. Transportation research Part D Transport and Environment.
- Central Bureau of Statistics. 2014. Nepal Public Land Transport Survey 2013. National Planning Commission Secretariat.
- China Daily. 2017. "TAILG plugs right into Belt and Road opportunities", in China Daily. Accessed at [http://usa.chinadaily.com.cn/epaper/2017-05/09/content\\_29267407.htm](http://usa.chinadaily.com.cn/epaper/2017-05/09/content_29267407.htm)
- Delucchi, M.A., 2000. Environmental externalities of Motor Vehicles Use in the US. Journal of Transport Economics & Policy 34 (2), 135–168
- Department of Transport Management. 2015. Vehicle registration data. Ministry of Physical Infrastructure and Transport
- EPI. 2016. Environmental Performance Index 2016. Yale University. [http://epi.yale.edu/sites/default/files/2016EPI\\_Full\\_Report\\_opt.pdf](http://epi.yale.edu/sites/default/files/2016EPI_Full_Report_opt.pdf)
- European Rare Earth (Magnet) Recycling Network. 2014. Rare earths in energy storage and conversion (2014). <http://erean.eu/wordpress/2014/10/>
- Ghimire, L.S. 2016. Nepal's Widening Trade Deficit (Some Issues, Challenges and Recommendations). Economic Management Division: Staff Discussion Paper. Nepal Planning Commission.
- Government of UK. Study Available at <https://www.gov.uk/noise-pollution-economic-analysis>. 2013.
- Global Asset Protection Services LLC. 2015. Vehicle Manufacturing.
- Global Green Growth Institute. 2014. "Green Growth Strategy for Karnataka." Case Studies. [http://gggi.org/wp-content/uploads/2014/12/Karnataka-GG-Case-Studies\\_FINAL\\_Web-Version.pdf](http://gggi.org/wp-content/uploads/2014/12/Karnataka-GG-Case-Studies_FINAL_Web-Version.pdf)
- Global Green Growth Institute, 2015. Electric Buses in India: Technology, Policy and Benefits
- Global Resources Institute. 2006. Electric Vehicles in Kathmandu. Global Resources institute (GRI). <http://www.grilink.org/ktm.htm>
- Greenstone, Michael, Janhavi Nilekani, Rohini Pande, Nicholas Ryan, Anant Sudarshan, and Anish Sugathan. 2015. "Lower Pollution, Longer Lives, Life Expectancy Gains If India Reduced Particulate Matter Pollution." Economic & Political Weekly.
- Lajunen, Antti. 2015. "Evaluation of Electric Buses." Alto University. [http://www.ecv.fi/@Bin/211333/ECV-seminariesity\\_10-3-2015\\_Evaluation-of-EBuses\\_Antti-Lajunen.pdf](http://www.ecv.fi/@Bin/211333/ECV-seminariesity_10-3-2015_Evaluation-of-EBuses_Antti-Lajunen.pdf)
- Mehrdad Ehsani et al., Modern electric, hybrid and fuel cell vehicles, fundamentals, theory and design.
- Ministry of Environment. 2011. Climate Change Policy. Government of Nepal.
- Ministry of Finance. 2016. Budget Speech 2016/17. Government of Nepal.
- Ministry of Physical Infrastructure and Transport. 2015. Environmentally Friendly Transport Policy 2015. Government of Nepal.

- <http://www.mopit.gov.np/uploads/files/policies&directives/Watawaranmaitri%20Sawari%20tatha%20Yatayat%20Niti%202071.pdf>.
- Ministry of Physical Planning and Works. 2001. National Transport Policy. Department of Roads. MoPPW, Government of Nepal.
- Ministry of Population and Environment. 2016. Nationally Determined Contribution. Communicated to United Nations Framework Convention on Climate Change, Ministry of Population and Environment (MoPE). Government of Nepal (GoN)
- Ministry of Science Technology and Environment. 2012. National Ambient Air Quality Standard.
- Ministry of Urban Development. 2017. National Urban Development Strategy 2017, Nepal. Urban Development and Physical Planning Division. Ministry of Urban Development (MoUD). Government of Nepal (GoN).
- M.J. Bradley & Associates LLC. n.d. "Comparison of Modern CNG, Diesel and Diesel Hybrid-Electric Transit Buses: Efficiency & Environmental Performance." <http://mjbradley.com/sites/default/files/CNG%20Diesel%20Hybrid%20Comparison%20FINAL%2005nov13.pdf>.
- Nepal Economic Forum. 2016. Post Disaster Assessment Blockade 2015/2016. Alliance for Social Dialogue.
- Nepal Electricity Authority. 2016. Annual Report.
- Nepal Oil Corporation. 2016. Sales of Petroleum Products. <http://www.nepalioil.com.np/import-and-sales-22.html>
- Nepal Oil Corporation. 2017. Oil prices.
- Nepal Planning Commission. 2015. Sustainable Development Goals 2016-2030. National (Preliminary) Report. National Planning Commission (NPC). Government of Nepal. [http://www.npc.gov.np/images/category/23rd\\_Jan\\_final\\_for\\_print\\_Sustainable\\_DevelopmentGoals1.pdf](http://www.npc.gov.np/images/category/23rd_Jan_final_for_print_Sustainable_DevelopmentGoals1.pdf)
- Noel, Lance, and Regina McCormack. 2014. "A Cost Benefit Analysis of a V2G-Capable Electric School Bus Compared to a Traditional Diesel School Bus." Applied Energy. <http://www.udel.edu/V2G/resources/V2G-Cost-Benefit-Analysis-Noel-McCormack-Applied-Energy-As-Accepted.pdf>.
- NPC. 2015b. Nepal earthquake 2015. Post Disaster Needs Assessment, Vol. A: Key Findings. National Planning Commission. <http://www.un.org.np/sites/default/files/PDNA-volume-B.pdf>
- NPC. 2017. Fourteenth Three Year Plan 2073/74-75/76. National Planning Commission. Government of Nepal.
- NRB. 2017. Summary of Monetary Policy for Fiscal Year 2074/75. Nepal Rastra Bank, Nepal.
- OECD. 2016. The economic consequences of outdoor air pollution. Policy Highlights. Organisation for Economic Co-operation and Development. <https://www.oecd.org/environment/indicators-modelling-outlooks/Policy-Highlights-Economic-consequences-of-outdoor-air-pollution-web.pdf>
- Rose, Jason C, and Michael A Staiano. 2007. "A Comparison of Green and Conventional Diesel Bus Noise Levels." In . Reno, Nevada. [http://staianoengineering.com/images/NC07\\_Ross\\_Staiano\\_-\\_A\\_comparison\\_of\\_green\\_and\\_conv.pdf](http://staianoengineering.com/images/NC07_Ross_Staiano_-_A_comparison_of_green_and_conv.pdf).
- Sen, A.K., Tiwari, G., Upadhyay, V. 2010. Estimating marginal external costs of transport in Delhi. Transport Policy; 17:27-37.
- Sengupta, R.P., Mandal, S., 2002. Health Damage Cost of Automotive Air Pollution: Cost-Benefit Analysis of Fuel Quality Upgradation for Indian Cities. Research Study for National Institute of Public Finance & Policy, New Delhi.
- Shakya, K.M., Rupakheti, M., Shahi, A., Maskey, R., Pradhan, B., Pandey, A., Puppala, S., Lawrence, M., Peltier, R. 2017. Near-road sampling of PM2.5, BC, and fine-particle chemical components in Kathmandu Valley, Nepal. Atmospheric Chemistry and Physics; 17: 6503-6516.
- Soni, A.R., Ballare, S., Chandel, M.K. 2014. Greenhouse gas mitigation potential of Mumbai's public transport system. Centre for Environmental Science and Engineering, Indian Institute of Technology Bombay, Mumbai, India.
- Truckaibus.com. 2015. "Tata Starbus 32 AC (BS4), ₹ 20,19,000." August 23. <http://www.truckaibus.com/new-cv/tata/starbus/tata-starbus-32-ac-bs4-8377-20-19-000-l1232.html>
- United Nations Centre for Regional Development, 2015. National Sustainable Transport Strategy. Ministry of Physical Infrastructure and Transport (MOPIT), Nepal Ministry of the Environment (MOE), Japan United Nations Economic and Social Commission for Asia and the Pacific (UN ESCAP).
- US Environment Protection Agency. 2015. Emission Factors for Greenhouse Gas Inventories. Center for Corporate Climate Leadership. [https://www.epa.gov/sites/production/files/2015-11/documents/emission-factors\\_nov\\_2015.pdf](https://www.epa.gov/sites/production/files/2015-11/documents/emission-factors_nov_2015.pdf)
- Wang, N. Li, Y. Liu, Y. 2014. Economic Evaluation of Electric Bus Charging Infrastructure. 17th International Conference on Intelligent Transport Systems (ITSC). IEEE.

WHO. 2016. Ambient air pollution: A global assessment of exposure and burden of disease. World Health Organization.

<http://apps.who.int/iris/bitstream/10665/250141/1/9789241511353-eng.pdf?ua=1>

World Travel and Tourism Council. 2017.

<https://www.wttc.org/research/economic-research/economic-impact-analysis/country-reports/>

World Bank. 2016. The Cost of Air Pollution. Strengthening the Economic Case for Action.

<http://documents.worldbank.org/curated/en/781521473177013155/pdf/108141-REVISED-Cost-of-PollutionWebCORRECTEDfile.pdf>

World Bank. 2017. CO2 emissions (kt). Carbon Dioxide Information Analysis Center, Environmental Sciences Division, Oak Ridge National Laboratory, Tennessee, United States.

<https://data.worldbank.org/indicator/EN.ATM.CO2E.KT?locations=NP>



## Annex 1 – Case Study Cities

### A. Electric Bus Initiative in the State of Karnataka

#### Background

Karnataka is the eighth most populous state in India, located in the southwest of the country. There is a high demand for mobility in the state. Road transport passenger demand was 180 billion passenger kilometers in 2010, out of which the passenger transport demand in urban areas like Bangalore was 100 billion passenger kilometers. A fourfold increase in demand for urban transport was observed in Karnataka during the last 20 years.<sup>88</sup>

Although the diesel bus fleet under management by Bangalore Metropolitan Transport Corporation (BMTC) is serving a large proportion of the population, it is also contributing significantly to air pollution in the city and state. Currently, there are more than 65,000 diesel buses in Bangalore being managed by BMTC, accounting for some 30% of the total particulate matter emissions in the city in 2010. It is estimated that the city has faced 1.7% loss in GDP due to air pollution from fossil fuel vehicles.<sup>89</sup>

#### Pilot Electric Bus Initiative

Owing to the high pollution caused by diesel buses in Bangalore, BMTC piloted a single electric bus for three months in 2014 to assess its direct and secondary monetary benefits.<sup>90</sup> Although this pilot project proved the viability of the vehicle, and the technology benefits of going electric, as well as received wide-spread consumer approval, its high

acquisition cost of INR 30 million (USD 460,334)<sup>91</sup> and lack of charging infrastructure posed a hindrance to further uptake of electric buses.

However, the Fast Adoption and Manufacturing of Electric Vehicles (FAME) scheme under the National Electric Mobility Mission Plan introduced in April 2015,<sup>92</sup> provided incentives for BMTC to increase the size of electric bus fleet. The FAME scheme<sup>93</sup> is designed to provide financial incentives for technology development, demand creation, pilot projects and charging infrastructure boosting growth in electric and hybrid vehicle adoption across India.

As a result, the BMTC partnered with the Global Green Growth Institute to analyse and support greater adoption of electric buses into the fleet. Part of this analysis included a review of benefits of switching to electric. In the case of Bangalore, the social benefit (i.e. improvement in public health) of replacing one diesel bus with an electric bus was estimated to be valued at INR 22.7 (USD 34,947).<sup>94</sup> In addition, the operation of pilot electric bus showed that noise levels decreased by 21%. There was also a decrease in the average maintenance and operation cost of the electric bus by 64% each when compared to the diesel bus.

#### Current Situation

As a result of these strong benefits and sound financial sense, BMTC initiated a formal procurement process for an additional 150 electric buses. Currently, the procurement team is exploring customization of the vehicles for

<sup>88</sup> GGGI 2014. Green Growth Strategy for Karnataka.

<sup>89</sup> Ibid.

<sup>90</sup> <https://www.mybmtc.com/en/press-release/approval-induction-150-electric-buses>

<sup>91</sup> 1 USD = INR 65.17

<sup>92</sup> <http://www.dnaindia.com/business/report-faster-adoption-and-manufacturing-of-electric-vehicles-in-2513405>

<sup>93</sup> A total of INR 1.97 billion (USD 30,2 million) was allocated for the FAME scheme in 2015/16 and 2016/17.

<sup>94</sup> Global Green Growth Institute, 2014. Green Growth Strategy for Karnataka: Case Studies.



Bangalore specifications. These electric buses are being partly financed by the FAME scheme.

## B. Electric Bus Initiative in the State of Himachal Pradesh

### Background

Himachal Pradesh is a state in the far north of India. A hilly state, it is famed for its tourism and natural landscape. Similar to Kathmandu, the number of privately owned vehicles in Himachal Pradesh is increasing at an annual average rate of 10%. This has led to significant congestion in the state's main cities, increasing air pollution and greenhouse gas emissions. In an effort to combat congestion and deliver efficient public transport solutions, Himachal Pradesh has envisioned adding some 1,500 buses to its fleet<sup>95</sup>.

### Pilot Electric Bus Initiative

An opportunity to shift towards electric buses was identified and Himachal Pradesh Road Transport Corporation (HRTC) and the Global Green Growth Institute partnered to support a pilot initiative. HRTC's main aim in introducing electric buses was to reduce greenhouse gas emissions, promote tourism and increase efficiency and profits<sup>96</sup>.

In the case of Himachal Pradesh, where many buses ply mountainous and hilly routes, at high altitudes in often sub-zero temperatures, electric buses present many advantages over diesel buses. Electric buses have far lower maintenance and repair costs, increasing the percentage utilization of the vehicle – on average it takes 40 days to repair a bus in Himachal Pradesh. In addition, electric buses can operate well even in sub-zero temperatures, such as those experienced along the Manali-Kullu and Mandi routes in the state. Previously, the waxing and gelling of diesel in diesel buses due to low temperatures would incur extra costs and reduce the efficiency of the buses. Another benefit of running electric buses in Himachal Pradesh is that since power generation is predominantly through run-off river hydropower plants, any excess electricity previously going to waste can be utilized by electric buses.

For the pilot, Goldstone Infratech Ltd, in partnership with BYD Auto Industry, developed a sample 25-seater bus for deployment in Himachal Pradesh. The vehicle, called a Goldstone eBuzz K7 electric bus, was supplied to HRTC. Two vehicles were deployed on the Kullu-Manalli-Rohatang pass route in September 2017.

### Current Situation

As a result of good performance of the Goldstone eBuzz K7, HRTC plans to procure an additional fifty units for deployment on various routes in the state<sup>97</sup>.

---

<sup>95</sup> GGGI. 2015. Deployment of Electric Buses in Himachal Pradesh: Pre-feasibility Report

<sup>96</sup> <https://chandigarhmetro.com/first-electric-bus-service-launched-himachal-pradesh-india-rohtang-manali/>

<sup>97</sup> <https://chandigarhmetro.com/first-electric-bus-service-launched-himachal-pradesh-india-rohtang-manali/>

## Annex 2 – Summary of Vendors

### Introduction

A number of vendors were engaged in discussions regarding viable electric bus models for deployment in Kathmandu. These vendors including the Nepal license holder of BYD, China; Ashok Leyland, India; the India office of KPIT, USA; and Hyundai, South Korea. In addition, a range of other manufacturers were reviewed for preliminary viability.

As noted in the preceding chapter, the two vendors whose vehicles were considered most viable - based on a combination of overall vehicle specifications, vehicle model

availability, price appropriateness, and vendor enthusiasm – were BYD and Ashok Leyland. The following are brief summaries of these vendors, and their principal product.

### Ashok Leyland, India

Ashok Motors was founded in 1948, becoming Ashok Leyland in 1955. The company is the second largest vehicle manufacturer in India, and fourth largest bus manufacturer in the world, with a turnover of USD 3.3 billion in 2016-17.



Source: Ashok Leyland

**Figure A.1. The Circuit by Ashok Leyland**

Ashok Leyland developed the first hybrid electric vehicle of India in 2002. Its first fully battery electric bus, the Circuit,

was developed during 2016 and released to the market in early 2017 – the first fully electric bus in India. It has a drive

range of 120 kilometers, powered by an imported, USA-produced lithium ion battery. It has a seating capacity of 31. The vehicle was specifically engineered to India's roads and terrain.

Fifty units of the model were sold in 2016, with some 200 units expected to be sold over 2017. The main market so far has been domestic.

## BYD (Build Your Dreams) Auto, China

BYD Auto is a Chinese vehicle manufacturer founded in 2003 in Xi'an, China. It is a subsidiary of BYD Company, which manufactures batteries. While the parent company engages in a diverse range of activities, BYD Auto is exclusively focused on the manufacture and distribution of passenger vehicles, buses, trucks and forklifts.

It produced its first mass-produced, plug-in hybrid car in 2008. Since then, it has expanded its fleet of electric vehicle models, and introduced a line of electric buses in 2010, which have been extremely popular, both in China and globally – selling some 1200 units in both 2011 and 2012, climbing to over 6000 units during 2015. BYD's was the first mass-produced pure battery electric bus in the world. This line, known as the K line, includes a range of electric transit buses of various lengths, capacity and specification. The

line of buses is powered by BYD's iron phosphate batteries, with a typical drive range of some 250 kilometers. Global distribution of K9s is supported by a global network of after-sales servicing centers, including in Nepal, where CIMEX Ltd has been granted exclusive license to distribute and service BYD products

### BYD K7

The BYD K7 bus is 8 meters long. The bus has a seating capacity of 23. The drive range of this bus is greater than 240 km. The battery capacity of the bus is 162 kWh, which takes less than three hours to charge at a fast charging station. In the region, BYD K7s have been running in China, Japan and India.

### BYD K9

The BYD K9 bus has a length of 12 meters and has proven to be a popular city transit bus around the world. It has a seating capacity of 30, with two folding seats and a single wheel-chair space. It has a top-speed of around 70 kilometres per hour and can manage route grades of up to around 15%. The battery has a capacity of 324 kilowatt hours, typically taking around six hours for an overnight slow charge (or three hours for a fast charge). In the region, Bangalore, India is running K9s, as are cities in Malaysia (Kuala Lumpur) and the Philippines. Japan, Hong Kong and Singapore have all signed contracts for K9s.



Source: BYD

Figure A.2. The K9 by BYD Auto