

Electric Buses in India: Technology, Policy and Benefits

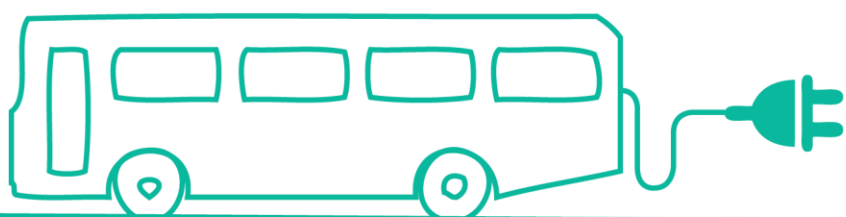

Electric Buses in India: Technology, Policy and Benefits

Copyright © (August) 2016

Disclaimer

The Global Green Growth Institute does not make any warranty, either express or implied, or assumes any legal liability or responsibility for the accuracy, completeness, or any third party's use or the results of such use of any information, apparatus, product, or process disclosed of the information contained herein or represents that its use would not infringe privately owned rights. The views and opinions of the authors expressed herein do not necessarily state or reflect those of the Global Green Growth Institute.

While every effort has been made to ensure the correctness of data/information used in this report, neither the authors nor GGGI accept any legal liability for the accuracy or inferences drawn from the material contained therein or for any consequences arising from the use of this material.

The report should be referenced as follows: Global Green Growth Institute and Center for Study of Science, Technology and Policy (2015). Electric Buses in India: Technology, Policy and Benefits, GGGI, Seoul, Republic of Korea

Text from this report can be quoted provided the source is acknowledged.

Acknowledgments

This report is based on close collaboration between Global Green Growth Institute (GGGI) and Center for Study of Science, Technology and Policy (CSTEP, Bengaluru). The contents were drafted by the technical team of CSTEP Bengaluru - Ganeshprasad Pavaskar, Anantha Lakshmi Paladugula, Vivek Vaidyanathan, Dr Mridula Dixit Bharadwaj, Sujaya Rathi, and CSTEP researchers Sonali Anusree, Ashish Nigam, Tanmay Sarkar, Amit Mookerjee and Dr Parveen Kumar with inputs from GGGI project team composed of Dr Prasoon Agarwal (Program Manager), Siddarthan Balasubramania (Country Head-India), Ankit Singhvi, Ram Prakash and Swati Sharma. The project team is grateful to the Communication and Policy Engagement team of CSTEP for their editorial support. The team would like to thank Bengaluru Metropolitan Transport Corporation (BMTc) - Managing Director, Dr Ekroop Caur for support and guidance. This initiative would not have been successful without the constant support and leadership provided by Professor B.K. Chandrashekar, Chairman, Bengaluru Climate Change Initiative-Karnataka (BCCI-K).

Contents

1.	Electric Vehicle in a Broader Public Transport Shift.....	12
1.1.	Increasing Motorization in India	12
1.2.	Transport Scenario Projections for India	14
1.3.	Avoid–Shift–Improve (ASI) Framework.....	15
1.4.	Effective Interventions.....	16
2.	Electric Vehicle Technology	18
2.1	Introduction	18
2.2	General Technology Landscape	18
	Comparison of Electric Vehicles versus Diesel and CNG.....	18
	Classification of EV segments.....	21
	Model-specific Data	33
	Assessment Framework Parameters	34
2.3	Battery and Charging Infrastructure	39
	Storage for Electric Transportation: Battery.....	39
	Battery Technologies for EV.....	40
	Battery Management System (BMS).....	42
	Charging Infrastructure: Technology Landscape	42
	Charging Technologies	43
	Types of Charging and Battery Swapping	45
	Components of a charging point system	46
	EV charging: Impact on Grid	47
3.	Impacts and Benefits.....	49
3.1	Air Quality	49
3.2	Noise	51
3.3	Energy Security	54
3.4	Jobs	56
4.	Policy Landscape	57
4.1	National Electric Mobility Mission Plan (NEMMP) 2020.....	57
4.2	Faster Adoption and Manufacturing of Electric Vehicles (FAME).....	58
4.3	National Green Tribunal (NGT)	59
4.4	Bureau of Energy Efficiency (BEE)/Star Ratings	59

4.5	National Auto Fuel Policy, 2003, Auto Fuel Vision & Policy, 2025	60
4.6	National Urban Transport Policy (NUTP)/Jawaharlal Nehru National Urban Renewal Mission (JNNURM)	60
4.7	Atal Mission for Rejuvenation and Urban Transformation (AMRUT)/ National Heritage City Development and Augmentation Yojana (HRIDAY)/Smart City Mission (SCM)	61
5.	Electric Vehicles – Technology Trends and Challenges.....	63
5.1.	Hype Cycle Analysis for Electric Vehicles Technology.....	63
5.2.	Hybrid Bus Deployment	64
5.3.	Battery Electric Bus Deployment	65
5.4.	Costs of BE Buses	67
5.5.	Charging Infrastructure for BE Buses	69
5.6.	Challenges for BE Buses	71
6.	References	75

Table of Figures

Figure 1.1 Total registered vehicles in India	12
Figure 1.2 Vehicles per 1,000 populations in various Indian cities.....	13
Figure 1.3 Traffic fatalities in India.....	14
Figure 1.4 Annual crude oil use and CO ₂ emissions.....	15
Figure 1.5 Avoid–Shift–Improve Approach.....	16
Figure 2.1 Classification of EVs	22
Figure 2.2 Schematic of an s-HEV	23
Figure 2.3 Schematic of a p-HEV	24
Figure 2.4 Schematic of a series–parallel (complex) hybrid electric vehicle	26
Figure 2.5 Schematic of a parallel PHEV	27
Figure 2.6 Schematic of a series–parallel (complex) PHEV.....	27
Figure 2.7 Schematic of BEVs.....	29
Figure 2.8 Efficiency of a BEV (on the left) vs. a fuel cell EV (on the right).....	31
Figure 2.9 Schematic of a series–parallel (complex) HEV	31
Figure 2.10 Schematic of an electric bus showing battery and electrical layout	43
Figure 2.11 Inductive charging in an electric bus	44
Figure 2.12 SAE J1772 2009 EV connector.....	47
Figure 2.13 EV connection cables	47
Figure 3.1 Estimates of PM _{2.5} concentrations across India	49
Figure 3.2 Annual environmental health losses per person of the exposed population.....	50
Figure 3.3 Bus categories, travel speed and associated noise levels.....	52
Figure 3.4 Crude oil prices in India, 2001–2015.....	55
Figure 3.5 Domestic crude oil consumption vs. domestic crude oil production	55
Figure 5.1 Gartner’s hype cycle for EV technology.....	63
Figure 5.2 Trend of LIB prices and future price predictions till 2030.....	67
Figure 5.3 Cycle life of a lead-acid battery at different Depths-of-Discharge (DoDs)	68
Figure 5.4 Cycle life of a typical LIB as a function of DoD at 25°C	69
Figure 5.5 Process of thermal runaway in LIBs	74

List of Tables

Table 1.1 Share of buses in India	13
Table 1.2 Average journey speeds in Indian cities.....	14
Table 2.1 Equipment comparison between a diesel bus and a BE bus.....	20
Table 2.2 General comparison of four types of buses	20
Table 2.3 Advantages and disadvantages of an s-HEV	23
Table 2.4 Advantages and disadvantages of p-HEVs	25
Table 2.5 Advantages and disadvantages of a series–parallel HEV	26
Table 2.6 Advantages and disadvantages of a PHEV	28
Table 2.7 Advantages and disadvantages a of BEV.....	29
Table 2.8 Summarized Comparison of p-HEV, HEV, and BEV	30
Table 2.9 Components and distribution of energy losses in a diesel bus and a BE bus	30

Table 2.10 Example of a populated table for a framework of analysis	34
Table 2.11 Diesel and electric bus key parameter comparison	38
Table 2.12 Summary of various battery systems with composition and performance characteristics...	41
Table 2.13 Comparison of conductive and inductive charging technologies	44
Table 2.14 Comparison among types of charging and battery swapping.....	45
Table 3.1 PM pollution standards in India	50
Table 3.2 Effects of noise on health – monetary values	54
Table 4.1 Potential adoption of EVs in India by 2020	57
Table 4.2 EVs - incentives in INR	59
Table 5.1 Trade-off between DoD and the life of the battery	68
Table 5.2 List of models and vendors available in India	69
Table 5.3 Total number of charging stations (EVSE) in various cities	70
Table 5.4 Charging standards for EVSE in Europe.....	71

Abbreviations and Acronyms

Abbreviation/Acronym	Full Form
ADA	Agra Development Authority
AMI	Acute Myocardial Infarction
AMRUT	Atal Mission for Rejuvenation and Urban Transformation
ASI	Avoid–Shift–Improve
BAU	Business As Usual
BEE	Bureau of Energy Efficiency
BEV	Battery Electric Vehicle
BHEL	Bharat Heavy Electricals Limited
BMS	Battery Management System
BMTC	Bengaluru Metropolitan Transport Corporation
BPKM	Billion Passenger Kilometers
BYD	Build Your Dreams
CAFC	Corporate Average Fuel Consumption Standards
CNG	Compressed Natural Gas
CPCB	Central Pollution Control Board
dB	Decibels
DHI	Department of Heavy Industries
DoD	Depth of Discharge
DSP	Digital Signal Processors
EGR	Exhaust Gas Recirculation
EV	Electric Vehicle
EVC	Electric Vehicle Charging
EVI	Electric Vehicles Initiative
EVSE	Electric Vehicle Supply Equipment
FAME	Faster Adoption and Manufacturing of Electric Vehicles
GBP	Great Britain Pound
GDP	Gross Domestic Product
GHG	Greenhouse Gas
GBP	Great Britain Pounds
HEV	Hybrid Electric Vehicle
HRIDAY	National Heritage City Development and Augmentation Yojana
ICE	Internal Combustion Engines
ICEV	Internal Combustion Engine Vehicles
IPCC	Intergovernmental Panel on Climate Change
IZET	India Zero Emission Transportation
JNNURM	Jawaharlal Nehru National Urban Renewal Mission
kWh	Kilowatt Hours
LIB	Lithium-Ion Battery
MoUD	Ministry of Urban Development
MW	Megawatts
NEMMP	National Electric Mobility Mission Plan

NGT	National Green Tribunal
Ni–Cd	Nickel–Cadmium
Ni–MH	Nickel–Metal Hydride
Ni–Zn	Nickel–Zinc
NM VOC	Non-methane Volatile Organic Compound
NREL	National Renewable Energy Laboratory
NUTP	National Urban Transport Policy
NYCT	New York City Transit
OBD	On-board Diagnostics
OCV	Open-Circuit Voltage
PHEV	Plug-in Hybrid Electric Vehicle
p-HEV	Parallel Hybrid Electric Vehicle
PM	Particulate Matter
PM-DC	Permanent Magnet-based motors
PV	Photovoltaic
ROI	Return on Investment
SAE	Society for Automotive Engineers
SCM	Smart City Mission
s-HEV	Series Hybrid Electric Vehicle
SMG	Seoul Metropolitan Government
SoC	State of Charge
SPV	Special-Purpose Vehicles
SRM	Switched Reluctance Motor
SRTU	State Road Transport Undertaking
TAP	Type Approval and Conformity of Production
TCO	Total Cost of Ownership
TfL	Transport for London
TOD	Transit-Oriented Development
USAID	United States Agency for International Development
USD	United States Dollars
WHO	World Health Organization

Executive Summary

Over the past decade, India's cities have been witnessing an increasing trend in motorization with deteriorating air quality, and there have been calls to promote public transport as a way out of this gridlock. It is in this context that electric buses can play a positive role, as there are several benefits associated with the shift from conventional diesel buses to electric buses in terms of reduction in local pollution, noise, and fuel consumption. In spite of the many positive benefits related to the electric bus technology, certain challenges remain. Primary among these are costs and safety concerns. Currently, the Electric Vehicle (EV) technology is associated with significant capital costs, with the battery component constituting about half of the total manufacturing costs. Safety is yet another important parameter, and the biggest concern is that of a fire hazard. However, with a good Battery Management System (BMS), rigorous implementation of standard operating procedures, and customization of bus fleet, both safety and cost aspects can be effectively addressed. Electric buses have already been deployed on a large scale globally, and the technology is mature and evolving continuously.

The current policy climate in India is rightly addressing the challenges of electric buses, providing an environment to accelerate their adoption and implementation. However, like any new technology, policy implementers, such as State Road Transport Undertakings (SRTUs), need a better understanding of the technology and policy landscape, along with a robust assessment of the benefits. In this context, the current report aims to serve as a reference document for adoption of electric buses in the Indian context, assessing their benefits and summarizing the policy and technology landscape. The first chapter of this report sets the context by stressing on the role that public transport can play in Indian cities to reduce the issues of congestion and pollution. In this context, this chapter emphasizes the need to adopt the Avoid–Shift–Improve (ASI) framework for achieving alternative mobility solutions and sustainable transportation systems. The second chapter of the report details current EV technology, specifically pure EVs. It lists the characteristics, pros and cons, and other technical aspects related to the EV technology. The third chapter of the report focuses on the benefits such as reduction in local air pollution, reduction in noise level, energy security, and the job creation potential that can be accrued on account of a shift to electric buses. The fourth chapter of the report provides details of various policies such as the National Electric Mobility Mission Plan (NEMMP), Faster Adoption and Manufacturing of Electric Vehicles (FAME), etc., instituted by the central government to promote the adoption of the EV technology. Chapter five of the report details the electric bus technology trends, including worldwide deployment, and safety issues with ways to address these.

1. Electric Vehicle in a Broader Public Transport Shift

1.1. Increasing Motorization in India

The total number of registered motor vehicles in India has increased rapidly over the past decade (2001–2011), from 55 million in 2001 to 142 million in 2011. This increase is represented in Figure 1.1. The Compounded Annual Growth Rate (CAGR) of registered motor vehicles was 10% against a population CAGR of 2% during 2001–2011. Of the total registered vehicles, two wheelers and cars contributed approximately 83% in 2012 (Ministry of Road Transport and Highways 2012b).

Figure 1.1 Total registered vehicles in India

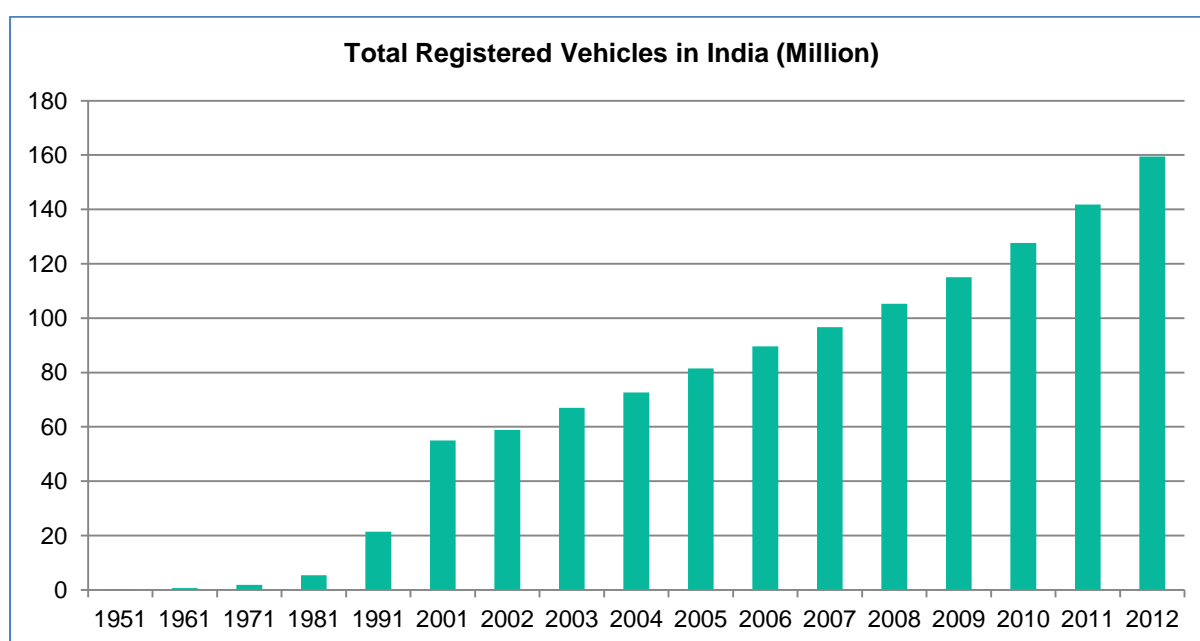

(Ministry of Road Transport and Highways 2012b)

Urbanization, increase in per capita income, lack of reliable public transport services, etc., are some of the important casual factors that have influenced the rapid motorization rates. The growth rates of population and registered vehicles are different for various categories of cities in India. Mumbai and Kolkata are some of the few cities in India that were planned based on a public transport network, and, hence, they have lower motorization rates. The National Urban Transport Policy, 2006, emphasized the need to prioritize the development of public transport and non-motorized transport in various urban areas to reduce motorization rates and promote sustainable transport. Rapid motorization has led to several impacts on various sectors, some of which are listed below.

Impacts of rapid motorization

- Increase in vehicle ownership
- Decrease in public transport shares
- Congestion (reduction in travel speed)
- Increase in accidents and fatalities
- Increase in air pollution.

Rapid motorization has resulted in an increase in vehicle ownership along with a decrease in public transport shares, increase in accidents, increased consumption of petroleum products and increase in air pollution. Figure 1.2 shows the vehicle ownership per 1,000 populations in various cities in India. It can be observed that there is an evident change in vehicle ownership levels in 2011 as compared with 2001 levels.

Figure 1.2 Vehicles per 1,000 populations in various Indian cities

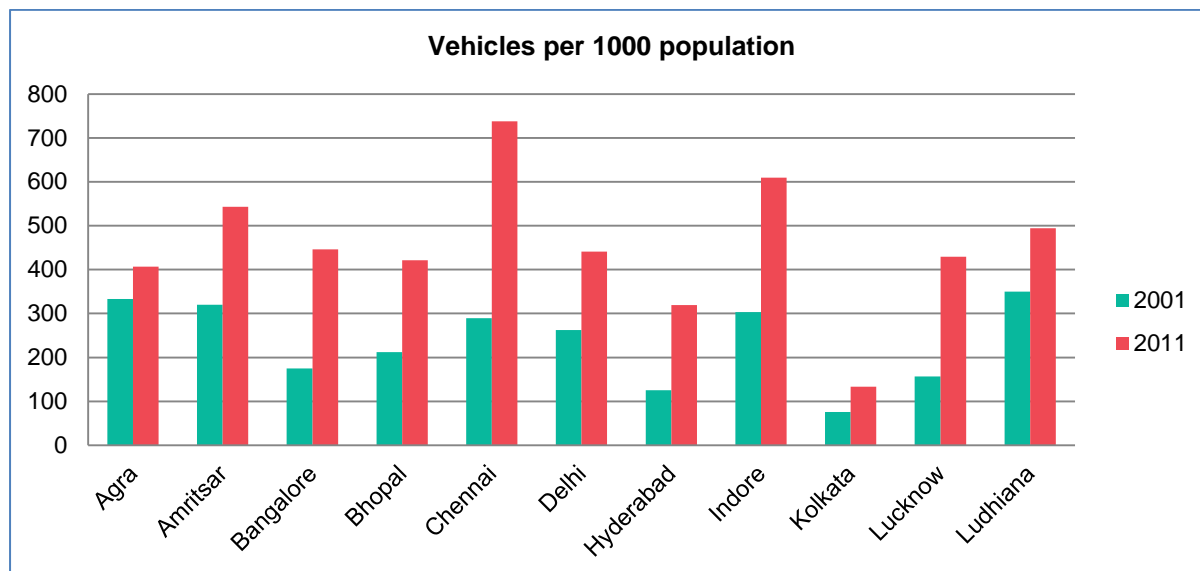

(Ministry of Road Transport and Highways 2012b)

The number of buses registered in 2011 was approximately 1.1% of the total number of registered vehicles, whereas the number of buses per capita was approximately 1,325 per million people in India. The share of buses in the total number of registered vehicles between 1951 and 2011 is given in Table 1.1.

Table 1.1 Share of buses in India

Year	Population (Million)	Total Registered Vehicles ('000)	Registered Buses ('000)	Buses to Million Population
1951	361	306	34	94.2
1961	439	665	57	129.8
1971	548	1,865	94	171.5
1981	683	5,391	162	237.2
1991	846	21,374	331	391.3
2001	1,027	54,991	634	617.3
2011	1,210	1,41,866	1,604	1,325

(Ministry of Road Transport and Highways 2012b)

The ease of access and direct point-to-point connectivity provided by private modes of transport such as two wheelers and cars have resulted in an increase in the number of per capita trips and long-distance trips. The increase in transport demand and motorization rates is much higher than the infrastructure supply. This has resulted in the utilization of road space by vehicles beyond the carrying capacity (of these roads), resulting in congestion during peak hours. The average speed in major cities in India is in the range of 15–18 kmph (which is equivalent to cycling speed – 15 kmph) as shown in Table 1.2.

Table 1.2 Average journey speeds in Indian cities

City	Average Speed (kmph)
Ahmedabad	15
Bengaluru	18
Chennai	15
Delhi	15
Hyderabad	15
Kolkata	18

(Ministry of Road Transport and Highways 2012b)

Rapid motorization combined with poorly planned infrastructure has resulted in an increase in the number of accidents and fatalities occurring every year. Figure 1.3 indicates the number of road fatalities per million populations, which has increased drastically from 27 in 1970 to 118 in 2011.

Figure 1.3 Traffic fatalities in India

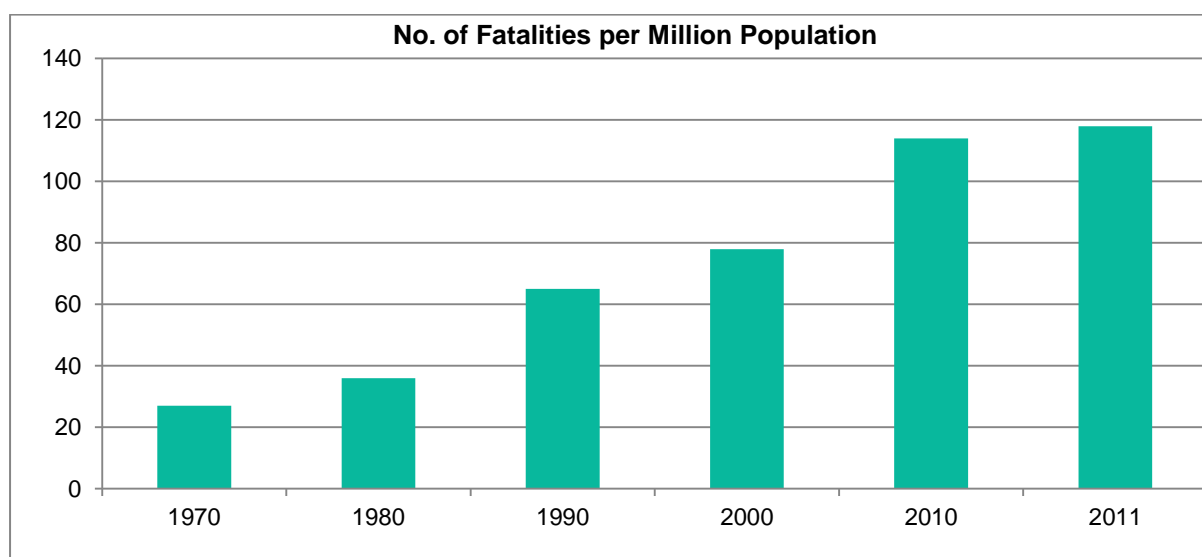

(Ministry of Road Transport and Highways 2012a)

1.2. Transport Scenario Projections for India

Currently, a large portion of the transport demand is met by private vehicles. Unless a greater share of this transportation need is met by public transport, the demand for crude oil as well as CO₂ emissions will reach untenable levels. A greater emphasis on public transport will certainly have a positive impact, but this will be of limited scope unless public transport vehicles shift their source of power from diesel to electricity. Current energy emissions as well as different scenarios based on the mode of interventions have been analyzed in this sub-section.

Current state of affairs

The number of registered motor vehicles in India has increased significantly over the past three decades, from 29.4 million in 1991 to 159.4 million in 2011, and this growth is likely to continue. Projections show that the passenger travel demand from urban areas will double by 2021 [1,448 Billion Passenger Kilometers (BPKM)] and triple by 2031 (2,315 BPKM), relative to 2011 levels (IUT and CSTEP 2014).

Figure 1.4 Annual crude oil use and CO₂ emissions

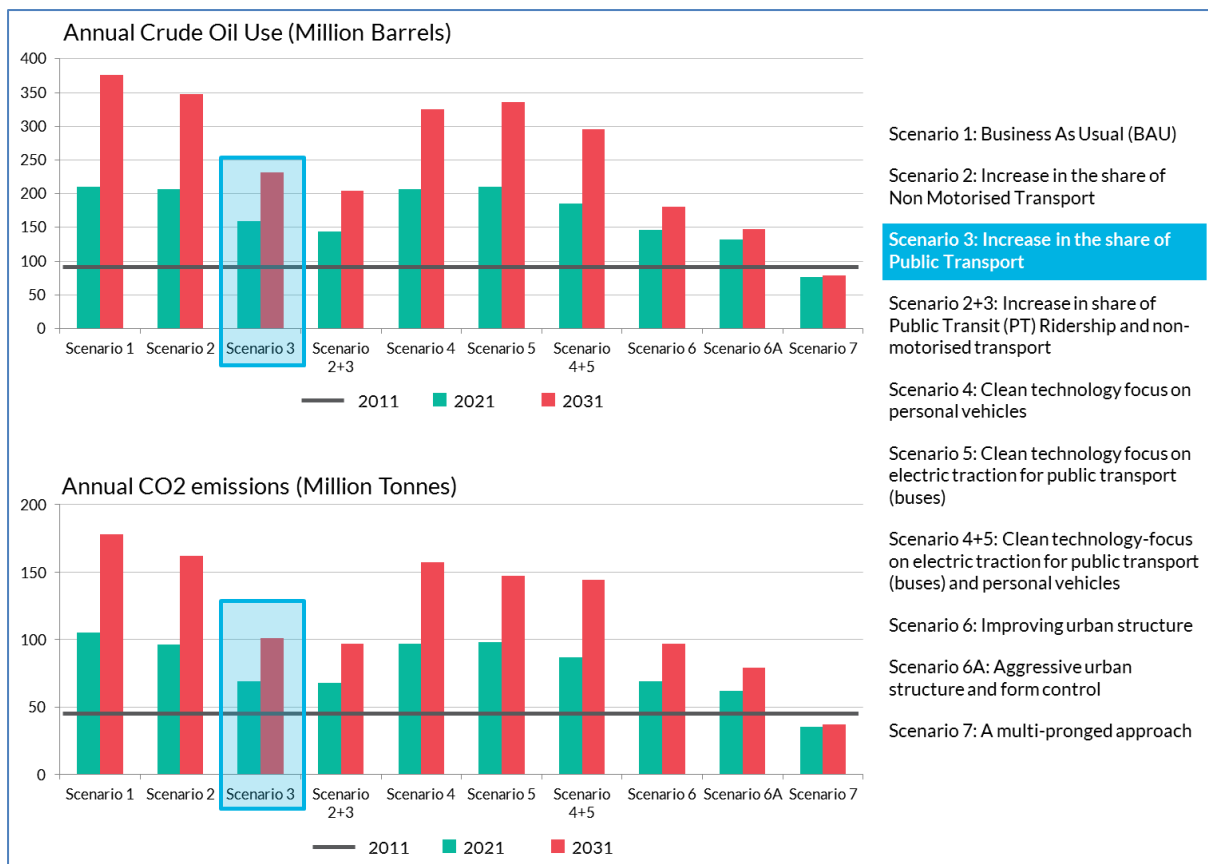

(IUT and CSTEP 2014)

If the share of private vehicles remains the same, this growth in the transport sector will result in the annual crude oil use to double by 2021 and almost quadruple by 2031 (Scenario 1, henceforth referred to as “Business as Usual” or BAU) as can be seen from

Figure 1.4. This raises serious concerns about India’s energy security. CO₂ emissions will also rise at similar rates. In addition, dependency on a diesel economy would likely result in increased Particulate Matter (PM) emissions, leading to increased rates of illnesses. A study conducted by the World Bank estimates that there is currently a loss of about 1.2% of India’s Gross Domestic Product (GDP) due to air pollution (World Bank 2013).

1.3. Avoid–Shift–Improve (ASI) Framework

The ASI framework is widely used for achieving alternative mobility solutions and sustainable transportation systems. Figure 1.5 shows the three main avenues that constitute the ASI framework.

Figure 1.5 Avoid–Shift–Improve Approach

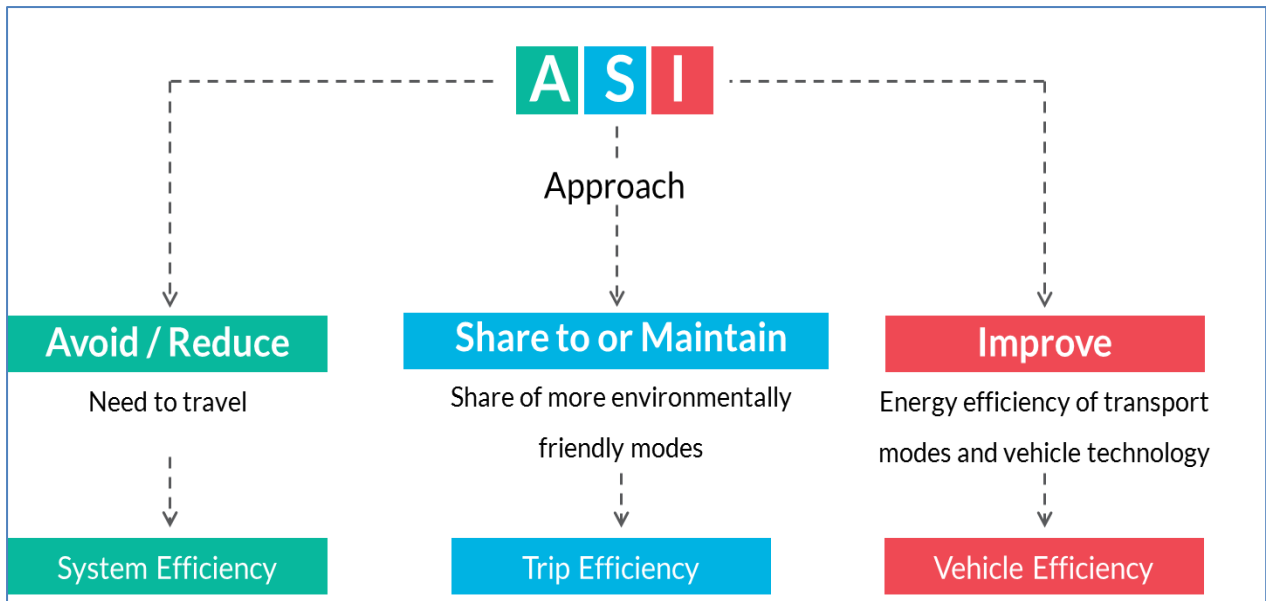

(Sustainable Urban Transport Project, n.d.)

The “Avoid/Reduce” component refers to the need for improved efficiency of transport systems. It aims to address energy use and emissions in the sector by slowing travel growth (or the need to travel) and reducing trip lengths via integrated land-use planning and travel demand management. Discouraging sprawl through minimum-density thresholds and prioritizing dense urban cores through Transit-Oriented Development (TOD) are some of the initiatives that can be used to achieve land-use integration. Similarly, demand management initiatives such as parking reform and road pricing, tools that focus on improving travel flow (e.g., advanced traffic signal control and real-time travel information), and virtual mobility programs (e.g., tele-working) can also be included to avoid travel.

The “Shift” component seeks to encourage a modal shift from motorized travel to more environment-friendly and energy-efficient modes. This can be achieved by promoting non-motorized (walking and cycling) and public transport. Initiatives to increase seamless, frequent and affordable public transport systems will lower the associated emissions per passenger-kilometer traveled, as well as reduce congestion while improving access and travel time.

The “Improve” component mainly focuses on technology improvements or advancements to achieve higher vehicle and fuel efficiency. This component includes stringent standards for fuel economy (removal of fuel subsidies and implementation of vehicle registration fees) and advanced vehicle technology penetration [clean diesel freight vehicles, Plug-in Hybrid Electric Vehicles (PHEVs), etc.]. The Improve component also includes initiatives to optimize the transport infrastructure.

The ASI framework also makes important contributions toward climate change. It provides a synergy between climate change mitigation and adaptation by developing transport strategies for highly efficient transport systems (mitigation), while making the transport system resilient to climate change (adaptation).

1.4. Effective Interventions

As discussed briefly in the previous section, any shift toward public transport would be most effective with a move to alternate technologies including EVs. The shift to electric buses by state transport undertakings combined with the adoption of the ASI framework would have a multiplier effect.

Effective interventions at the city level require that project implementers understand the drive cycle for battery sizing so that the requirements are not over-engineered. This would ensure that electric buses are cost-effective. Similarly, pure electric buses with zero tail-pipe emissions offer a unique opportunity to reduce pollution at a given location, thereby contributing positively to health indicators as well.

Policies such as the National Electric Mobility Mission Plan (NEMMP), Faster Adoption and Manufacturing of Electric Vehicles in India (FAME), Smart City Mission and other similar schemes are unique opportunities for city bus corporations to fund the acquisition of electric bus fleets.

In the recent past, there have been certain positive examples in the use of EVs for mass transport. In Agra, a zero-emission corridor was initiated to reduce vehicular air pollution by restricting the movement of conventional vehicles within a radius of 1.5 km around the Taj Mahal. To support this initiative, Maximo electric vans with a seating capacity of seven are being promoted by the Agra Development Authority (ADA) for last-mile connectivity (2 km). Prior to this initiative, the ADA supported 12 “Electravan” battery-powered vehicles developed by Bharat Heavy Electrical Limited (BHEL). In 2001, the United States Agency for International Development (USAID) along with Bajaj Auto Limited and other local partners initiated the development of EVs (three-wheelers) and their use in Agra under the India Zero Emission Transportation (IZET) program.

2. Electric Vehicle Technology

2.1 Introduction

EVs are powered by electricity and propelled by traction motors. In conventional vehicles, Internal Combustion Engines (ICEs) and fossil fuels are used instead of traction motors and an electricity source. EVs can use electric energy from on-board sources such as a battery or an electricity generator connected to the ICE, or off-vehicle energy sources such as overhead lines. EVs have applications in road and rail transportation, surface and underwater transport, and electric aircrafts.

The Global EV Outlook report, published by the Electric Vehicles Initiative (EVI)¹, estimates that the global EV stock in 2014 was more than 6,65,000 vehicles, while the annual sales number for EVs was 113,000 in 2013. The report also concluded that overall EV sales are growing rapidly – 70% growth in 2013 and 53% growth in 2014. The percentage share of Battery Electric Vehicles (BEVs) in the total number of EVs sold is increasing every year – 49% in 2012, 54% in 2013 and 57% in 2014 (Clean Energy Ministerial, Electric Vehicles Initiative, and International Energy Agency 2013). China is currently operating 36,500 electric buses as compared with a negligible number of electric buses in India (Electric Vehicles Initiative and International Energy Agency 2015).

A shift to an electric bus fleet necessitates an understanding of the technology. The design of an electric bus and the necessary infrastructure depend on the application scenarios. The battery size depends on the drive cycle, terrain features and other operating conditions. The battery system preference depends on the operating conditions of the vehicle. The cost is determined by the bus and the battery size, battery type and carrying capacity. Thus, having a fundamental understanding of the technology landscape and application scenarios is important. Understanding future developments and industry expectations will give a sense of the direction in which the electric bus sector is heading.

This chapter covers technical details related to electric buses (mainly BEVs), specifically the aspects of battery technology, including the grid and charging infrastructure necessary to power and maintain a pure electric bus fleet. It discusses the general technology landscape, technology trends and challenges. The general technology landscape section showcases a comparison matrix among four segments: Diesel, CNG, Hybrid Electric Vehicle (HEV) and BEV. This is followed by the classification of EVs by type, including the advantages and disadvantages of each category. Subsequently, details of the main components of BEVs are provided. In addition, the types of batteries along with the parameters affecting their performance are discussed. The chapter also includes sub-sections on battery sizing and Battery Management System (BMS). In a later section, technology trends have been summarized, wherein past rollouts have been evaluated to identify the successes and failures along with a mapping of global best practices. Technical advances in BEVs have also been discussed in the same section. The key challenges associated with the different sectors of the electric bus technology have been described, along with challenges faced by the battery technology in relation to BMS, performance, temperature endurance and durability. At the end of this technology assessment chapter, a list of electric bus vendors has been provided.

2.2 General Technology Landscape

Comparison of Electric Vehicles versus Diesel and CNG

Even though EVs demonstrate significant benefits in terms of environmental impact and energy security, their main competition still remains with conventional Internal Combustion Engine Vehicles (ICEVs). This is mainly attributed to a well-established supply chain and ease of operation of ICEVs, which give it an edge over EVs. It is important to view an overall comparison between the EV and ICEV technologies, which have been analyzed

¹ The Electric Vehicles Initiative (EVI), a forum that draws its membership from 16 member countries, seeks to deploy 20 million EVs by 2020.

in this chapter. They have been further categorized into two segments each: Diesel and CNG, and HEV and BEV. While this chapter analyzes the deployment of buses, it is to be noted that India does not have petrol-based bus models; it uses either diesel or CNG buses for transport operations. India has deployed a few electric buses, which consist of hybrid buses and Battery Electric (BE) buses.

Vehicle segment terminology: Since this chapter is focused on the bus segment, the following terms have been used interchangeably:

1. Conventional ICE Vehicles (ICEVs) – ICE buses
 - a. Diesel-based vehicle – diesel bus
 - b. CNG-based vehicle – CNG bus
2. Electric Vehicles (EVs) – electric buses
 - a. Hybrid Electric Vehicles (HEVs) – hybrid bus
 - b. Battery Electric Vehicles (BEVs) – BE bus².

The external features of the BE bus design are similar to those of an ICE bus. The main difference is that BE buses do not have a tail pipe. However, the internal design of the components is moderately different among ICEV, HEV and BEV buses. According to California's Advanced Transportation Consortium, up to 70% of the components of an electric bus can be different from those of an ICE bus (Advanced Vehicle Testing Activity, n.d.). Diesel and CNG buses have almost similar components. Diesel, CNG and hybrid electric vehicles have a distinct feature; all of them have a fuel tank, which is absent in BEVs. Diesel and CNG buses have only one energy source, ICE, which uses diesel and CNG as fuel, respectively. A hybrid bus contains both an ICE and a battery pack with an electric motor.

It is well established in the literature that the use of BEVs will bring down the overall Greenhouse Gas (GHG) emissions (IEA 2012). This can be attributed to the following aspects:

1. Electricity from renewable sources can be used to power the vehicle
2. The same fuel is burnt more efficiently at thermal power plants (to produce electricity for charging) as compared with that in an ICE.

However, the prices of EVs are much higher than that of ICEVs (Delucchi 2001)(Noel and McCormack 2014). This is mainly attributed to battery costs, the complex design of powertrain systems and nascent technology. Since HEVs are powered by an ICE and a battery with an electric motor, they cost the most among the four vehicle segments.

The number of moving parts in a BE bus is less than those in diesel and CNG buses. On the other hand, HEVs have more moving parts, making their design more complicated amongst the four vehicle segments. Therefore, diesel, CNG and hybrid buses have higher maintenance requirements as compared with those of BE buses (Noel and McCormack 2014). The types of maintenance in diesel buses include frequent oil changes, filter replacements, periodic tune ups, exhaust system repairs, water pump, fuel pump and alternator replacements, etc. The maintenance requirement for hybrid buses can be similar, or higher, than those of diesel and CNG buses (Noel and McCormack 2014).

BE buses have controllers and chargers, which manage the power and stored energy levels in the battery. These are electronic devices without any moving parts, and, hence, they require little or no maintenance. The Lithium-Ion Batteries (LIBs) that are used in electric buses require minimal maintenance (Albright, Edie, and Al-Hallaj 2012). Battery replacement is one type of maintenance, which is undertaken once every few years. New R&D advancements aim to make batteries co-terminus with the service life of a bus. Battery charging, which is similar to refueling, is not considered maintenance work, even though it contributes to significant downtime in bus operations. In developed electricity markets, due to a Time of Usage (ToU) tariff policy, off-peak charging allows the application of lowest utility rates (M.J. Bradley & Associates LLC, n.d.). The total cost of operating a

²Henceforth, BE bus will refer to pure electric buses.

BE bus is less as compared with ICE buses due to low maintenance, cheap power and high fuel efficiency. However, high initial capital costs in the form of bus price and charging infrastructure make BE buses expensive. Therefore, the majority of the costs in the total cost of operations of BE buses are depreciation and financing costs (interest on loan). Similarly, the majority of the cost in the total cost of operations of ICEV buses is fuel costs (Global Green Growth Institute 2014).

Table 2.1 Equipment comparison between a diesel bus and a BE bus

Diesel Bus	Function	BE Bus
Diesel tank	Energy source	Battery
Diesel pump	Replenishing energy source	Charger
Diesel engine	Mechanical energy generator	Traction motor
Mechanical carburetor	Speed and acceleration control	Electronic controller
Alternator	Power supply to accessories	Electronic power converters
–	Regenerative braking	Motor/generator

(CSTEP research)

According to a study that compared modern CNG, diesel and diesel hybrid-electric transport buses, diesel and CNG buses exhibit equivalent overall drivetrain efficiency. Diesel-hybrid buses show better performance, with 7%–44% higher fuel economy than diesel and CNG buses at slow and medium speeds. However, the fuel economy for a hybrid bus is reported to be the same, or lower, than that of a diesel bus at high speeds. The majority of city transport buses (90%) operate at slow or medium speeds (M.J. Bradley & Associates LLC, n.d.).

Table 2.2 General comparison of four types of buses

Parameters	BE Bus	Hybrid Bus	CNG Bus	Diesel Bus
Power source	Electricity	Electricity + fuel (Diesel or CNG)	CNG	Diesel
Power generator	Battery	IC engine + Battery	IC engine	IC engine
Costs (INR)	2.6 crores ³	>3 crores ⁴	20–88 lakhs ⁵	20–88 lakhs ⁶
Fuel efficiency	1.5 kWh/km ⁷	2.75–4 km/L ⁸	2–3 km/kg	2.2–3.3 km/L ⁹
Fuel tariff	6.95 INR/kWh ¹⁰	50 INR/L ¹¹	40 INR/kg	50 INR/L
Fuel cost¹²	INR 10/km	INR 13–17/km	INR 13–20/km	INR 15–23/km

³(Global Green Growth Institute 2014).

⁴(Noel and McCormack 2014).

⁵(Global Green Growth Institute 2014; “Tata LPO 1613 CNG (Bus/CHS), ₹ 16,09,000” 2015).

⁶(Global Green Growth Institute 2014; Truckaibus.com 2015).

⁷(Global Green Growth Institute 2014).

⁸(M.J. Bradley & Associates LLC, n.d.).

⁹(Global Green Growth Institute 2014).

¹⁰(Electricity Supply Company Ltd 2014).

¹¹(MyPetrolPrice.com 2015).

¹² Fuel cost per km is calculated using fuel efficiency and fuel tariff.

Emissions¹³	Zero (local)	Low (less CO ₂ , SO _x , NO _x and NMHC)	Low (equal CO ₂ , less SO _x , NO _x and NMHC)	High (baseline)
Noise¹⁴	Minimum (at slow speeds)	Low (at slow speeds)	High	High (baseline)
Secondary benefits	High	Moderate	Low	Low
Major cost share in TCO¹⁵	Depreciation and financing cost	Depreciation and financing cost	Fuel	Fuel
Maintenance	Lowest	High	High	High
Components	EV propulsion system, transmission, battery charging system, power accessories, body	ICE propulsion system, EV propulsion system, transmission, battery charging system, power accessories, body	ICE propulsion system, transmission, power accessories, body	ICE propulsion system, transmission, , power accessories, body

Classification of EV segments

As mentioned in the earlier section, electric buses are categorized in two segments: BE buses and hybrid-electric buses. BE buses, also known as fully electric buses, have an electric propulsion system, which consists of a battery and an electric motor connected to the driveshaft. The energy required to propel the vehicle is provided solely by the battery. A hybrid bus has two types of energy sources in its powertrain – a conventional ICE and a battery with a traction motor connected to the driveshaft. This makes hybrid buses heavy and expensive.

Hybrid buses are further classified into the following segments according to their drivetrain configuration: parallel Hybrid Electric Vehicle (p-HEV), series Hybrid Electric Vehicle (s-HEV) and series-parallel HEV. A p-HEV can use both propulsion systems either simultaneously, or separately use ICE propulsion for acceleration and high speeds and electric propulsion at steady cruising speeds. In an s-HEV, the ICE generates energy, which is converted to electricity, which is applied to propel the vehicle and also to charge the battery. A series-parallel HEV has a powertrain designed in such a way that it can act as an s-HEV and/or a p-HEV at multiple driving modes.

Plug-in-type electric vehicles have two variants, BEV and p-HEV. All segments of electric buses, which feature kinetic energy recovery systems, improve the energy efficiency (MIT Electric Vehicle Team 2008)(Environment and Energy Study Institute 2001). The general technology classification is shown in the following diagram (Figure 2.1).

¹³(Global Green Growth Institute 2014; International Energy Agency 2012).

¹⁴(Verheijen and Jabben 2010).

¹⁵(Global Green Growth Institute 2014).

Figure 2.1 Classification of EVs

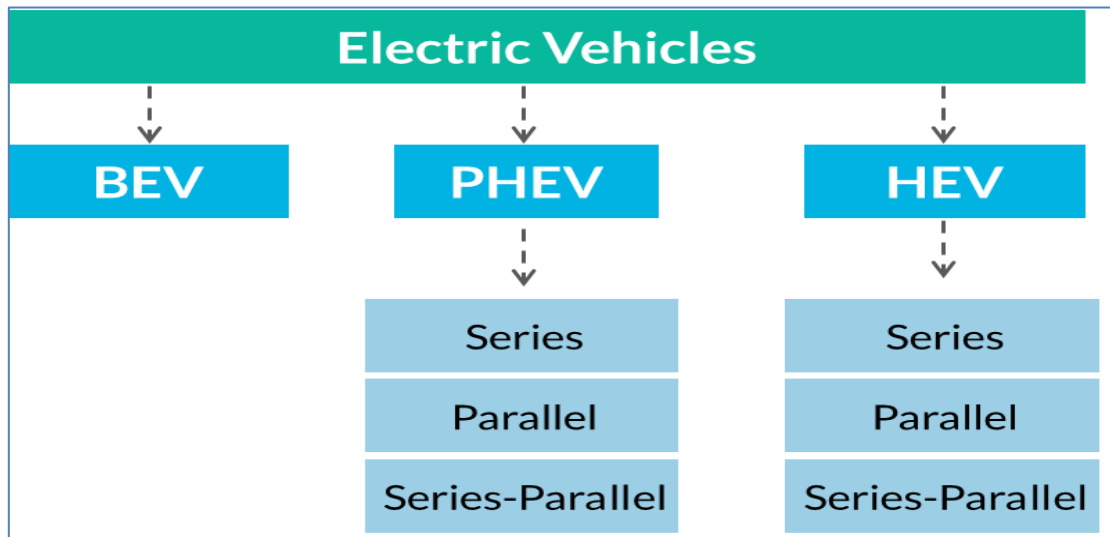

(Environment and Energy Study Institute 2001; MIT Electric Vehicle Team 2008; Wroclaw University of Technology 2011)

A. Hybrid Electric Vehicles

1. Mild Hybrid Electric Vehicles

A mild hybrid is the least electrified type of HEV. A mild HEV contains an ICE with an oversized starter motor, which is also utilized as a generator. This electrical machine is called a 'starter-generator' or a 'belted alternator starter'. It contains a battery pack that is charged by the starter generator. Electric-only propulsion mode is not present in the mild HEV. The motor/generator is utilized when the vehicle is braking or is stopped. The engine can be switched off at this time. However, the engine must be on when the vehicle is accelerating or moving at constant speed. The engine recharges the battery at low load levels on the vehicle. At higher amounts of load, the energy from the battery can be utilized to get better performance. As a mild hybrid has a very small battery as compared with the other hybrid types, its performance enhancement is very small.

2. Series Hybrid Electric Vehicles (s-HEVs)

In HEVs, there are two energy sources – battery with a motor and an ICE. In an s-HEV, these two power sources are connected in a series. The energy created in the ICE is fed to the generator, which converts the mechanical energy to electrical energy. The electrical energy thus charges the battery, which provides the energy to run the traction motor, which pushes the wheels. Therefore, there is a single path of energy flow from the ICE to the wheels of the vehicle, even though two energy sources are used. Figure 2.2 represents the schematic of the power generation and transmission in an s-HEV. The motor/generator is also used to recharge the battery during deceleration and braking. The amount of energy that can be stored is very high as compared with that in mild hybrids and p-HEVs. Therefore, s-HEVs provide better performance enhancement.

Figure 2.2 Schematic of an s-HEV

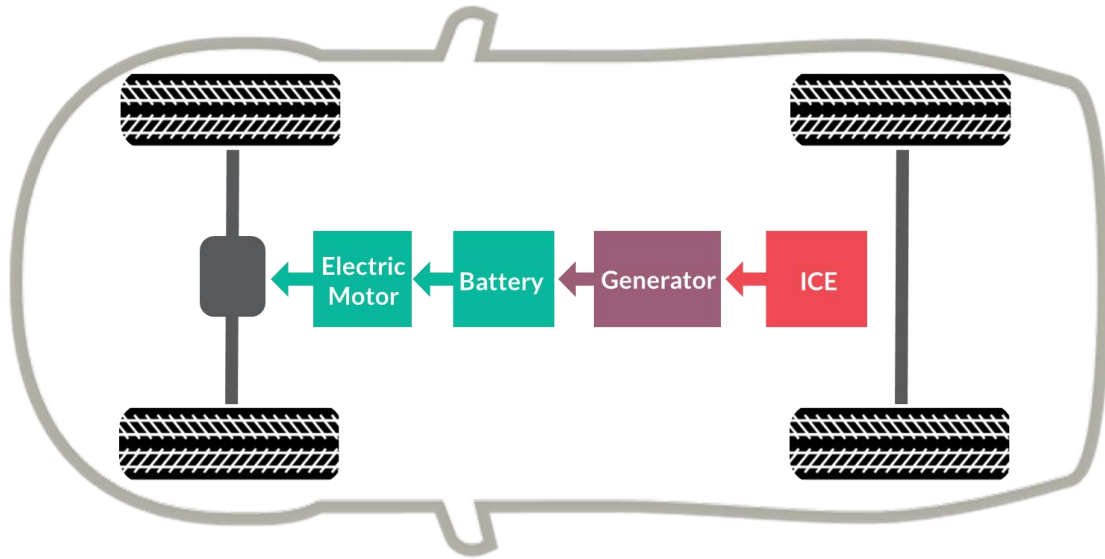

(Environment and Energy Study Institute 2001; MIT Electric Vehicle Team 2008; Wroclaw University of Technology 2011)

Application of s-HEVs: slow traffic, e.g., city-drive conditions (frequent stop-and-go).

In long-range drives (e.g., highway conditions) or at constant-speed drives, the fuel efficiency of an s-HEV decreases due to additional energy conversions. These consist of conversions of mechanical to electric energy in the generator, electric to chemical energy in the battery, and electric to mechanical in the electric motor. However, at slow speeds or in frequent stop-and-go traffic, energy is not wasted due to the regenerative braking mechanism. In the regenerative braking mechanism, the energy wasted in deceleration is stored in the battery. Therefore, an s-HEV has better utility in city-driving conditions.

Table 2.3 Advantages and disadvantages of an s-HEV

Advantages	Disadvantages
Transmission system design is simple	Total weight and costs of vehicle are high
Narrow RPM range for ICE (simple ICE design)	Energy efficiency is low in long-distance drives
Energy efficiency is high in stop-and-go traffic	

(Environment and Energy Study Institute 2001; MIT Electric Vehicle Team 2008; Wroclaw University of Technology 2011)

s-HEVs can have multiple modes of operations, according to their speed and acceleration patterns. It can operate in seven different modes:

1. Engine-only traction
2. Electric-only traction
3. Hybrid traction
4. Engine traction and battery charging
5. Battery charging and no traction
6. Regenerative braking
7. Hybrid battery charging.

The component list includes an ICE propulsion system, an EV propulsion system, battery charging, power accessories, body design and transmission.

The majority of the components of an s-HEV are similar to those in diesel or CNG buses. The additional components include a battery and battery charging-related components such as a motor/generator, a BMS, etc.

3. Parallel Hybrid Electric Vehicles (p-HEVs)

In p-HEVs, the ICE and battery/motor are connected in a parallel configuration. The fuel is burnt in the ICE to create energy, which is directed to the transmission, and in turn reaches the wheels of the vehicle. The stored electric energy from the battery is also fed to the tires using electric motor and transmission. Therefore, there are two paths of power transmission – from ICE to wheels (engine path), and battery to wheels (battery path). The amount of energy needed to be stored in the battery is less as compared with that in an s-HEV. Therefore, the overall energy demands on the motor of a p-HEVs are smaller and they have smaller battery packs. Figure 2.3 shows the schematic of the power generation and transmission in p-HEVs. The motor/generator is also used to recharge the battery during deceleration and braking. In the case of a plug-in type of p-HEV, energy is taken from the grid and stored in the battery. The controls of a p-HEV are much more complex than those of an s-HEV because of the need to efficiently couple the motor/generator and the ICE to manage the driveability and performance of the p-HEV.

Figure 2.3 Schematic of a p-HEV

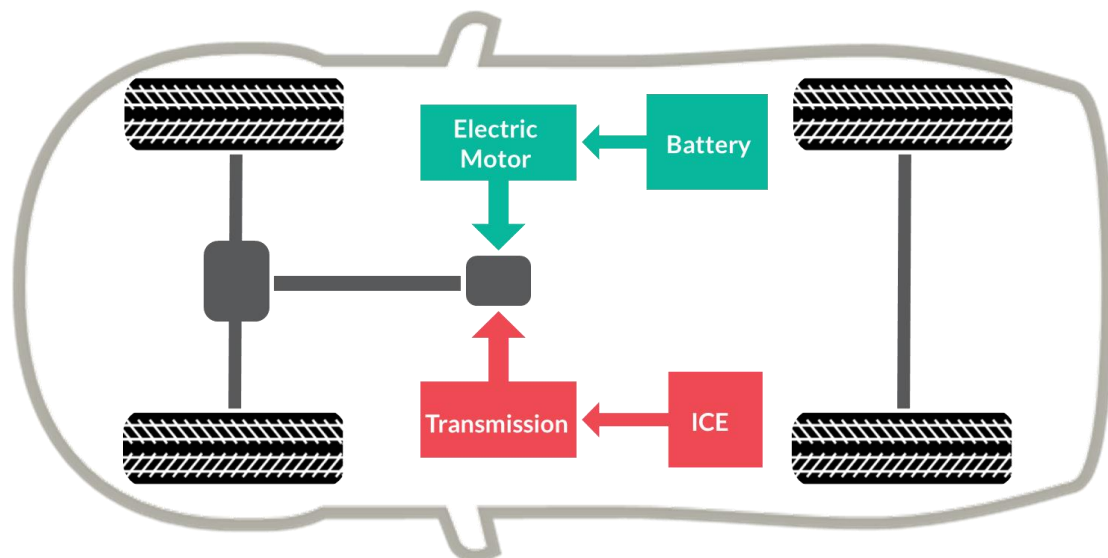

(Environment and Energy Study Institute 2001)(MIT Electric Vehicle Team 2008)(Wroclaw University of Technology 2011)

Application of a p-HEV: fast traffic, intercity or highway drive.

In long-range or constant-speed drives, fuel efficiency does not decrease because all the energy generated in the ICE is directly fed to the wheels of the vehicle. Due to the absence of multiple energy conversions, a p-HEV has good fuel efficiency at high speeds. At slow speeds, i.e., in frequent stop-and-go kind of urban traffic, energy is wasted in direct power transmission from the ICE to wheels. In the regenerative braking mechanism, the energy wasted in deceleration is stored in the battery. This increases the fuel efficiency of the vehicle. Therefore, a p-HEV has better utility under highway driving conditions. The main difference between plug-in type of p-HEV and a normal p-HEV is the battery-size requirement, with a plug-in p-HEV requiring a bigger battery pack.

Table 2.4 Advantages and disadvantages of p-HEVs

Advantages	Disadvantages
Battery and engine are smaller in size, and, therefore, less expensive than s-HEVs	System design is complicated due to two power transmission paths
Energy efficiency is high in long-distance drive	Broad RPM range for ICE (expensive ICE design)
	Energy efficiency is low in stop-and-go traffic

(Environment and Energy Study Institute 2001)(MIT Electric Vehicle Team 2008)(Wroclaw University of Technology 2011)

p-HEVs can have multiple modes of operations, according to speed and acceleration patterns. A p-HEV can operate in five different modes:

1. Engine-only traction
2. Electric-only traction
3. Hybrid traction
4. Regenerative braking
5. Battery charging from the engine.

The component list includes an ICE propulsion system, an EV propulsion system, battery charging, power accessories, body design and transmission.

The majority of the components are the same as those in diesel or CNG buses. Additional components are battery and battery charging-related components such as motor/generator, battery management system, etc.

4. Series–Parallel Hybrid Electric Vehicles

Like all other hybrids, there are two energy sources in series–parallel hybrid vehicles. The energy created in the ICE is directed to the transmission, which propels the vehicle. Additionally, the energy from the battery is also fed to the wheels using the electric motor and transmission. In series–parallel HEVs, the ICE and battery exist in three possible powertrain configurations – parallel, series, and simultaneous series and parallel configuration, which is also called complex configuration. Therefore, there are three paths of power transmission – ICE to wheels (engine path), battery to wheels (battery path), and a third, which is a combination of these two paths. In the case of plug-in series–parallel hybrid vehicles, energy is taken from the grid and stored in the battery. The design of series–parallel hybrids is the most complicated among that of all vehicle types.

The controllers need to be designed such that the system of motors and generators can charge the batteries using the gearing device or the power-split device. It can charge the battery even when the ICE is in propulsion mode.

Figure 2.4 presents the schematic of power generation and transmission in series–parallel HEVs. The motor/generator is also used to recharge the battery during deceleration and braking. The amount of energy that can be stored in the battery is similar to that in s-HEVs. Therefore, series–parallel hybrids have bigger battery packs than p-HEVs. Controllers manage the driveability and performance of the vehicle through efficient coupling of the motor/generator and the ICE. These series–parallel HEVs are also called complex hybrids because the powertrain design is the most complex. They are the most expensive among all the HEVs.

Figure 2.4 Schematic of a series–parallel (complex) hybrid electric vehicle

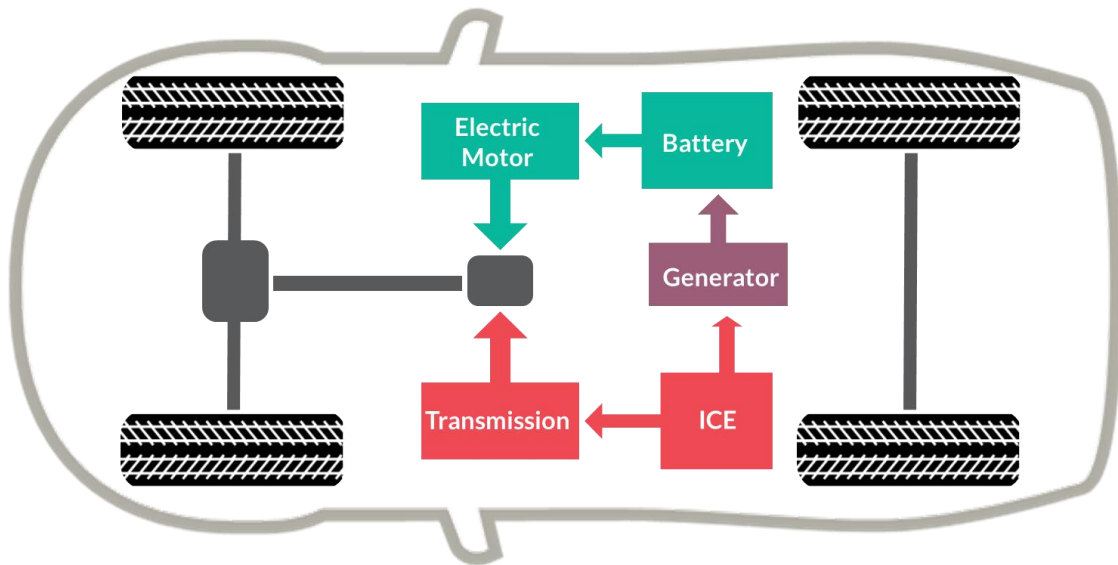

(Environment and Energy Study Institute 2001; MIT Electric Vehicle Team 2008; Wroclaw University of Technology 2011)

Application of series–parallel hybrid buses: both fast and slow traffic (highway and city drive).

In long-range or constant-speed drives, fuel efficiency does not decrease because all the energy from the ICE is directly fed to the wheels of the vehicle. At slow speeds, i.e., in stop-and-go kind of traffic, energy is not wasted because the “electric-only” mode takes over. Therefore, series–parallel HEVs are fuel-efficient in both slow and fast traffic. Series-parallel HEVs can have multiple modes of operations according to speed and acceleration patterns. It can operate in all modes that s-HEVs and p-HEVs operate.

Table 2.5 Advantages and disadvantages of a series–parallel HEV

Advantages	Disadvantages
Smaller, lighter and efficient ICE design	Very complicated design
Maximum flexibility to switch between electric and ICE power	Multiple conversions lead to a lower efficiency at particular driving modes
	More expensive than s-HEVs

(Environment and Energy Study Institute 2001)(MIT Electric Vehicle Team 2008)(Wroclaw University of Technology 2011)

The component list includes an ICE propulsion system, an EV propulsion system, battery charging, power accessories, body design and transmission.

The majority of the components are the same as in diesel or CNG buses. Additional components are battery and battery charging-related components such as motor/generator, battery management system, etc.

5. Plug-in Hybrid Electric Vehicles

A Plug-in Hybrid Electric Vehicle (PHEV) is a type of HEV that can be plugged in and recharged using electricity from the grid. An HEV can be converted into a PHEV by adding additional battery capacity and modifying the vehicle controller and energy management system. PHEVs are fully hybrid. They can run in the electric-only mode as well as the ICE-only mode over long driving distances. The major difference between a normal HEV and PHEVs is that PHEVs have very big battery packs. The biggest benefit that PHEVs provide is that they can

be fuel-independent for shorter daily transport and also for long-distance trips by switching to the ICE mode. PHEVs can be of any hybrid configuration, i.e., series HEV, parallel HEV and complex HEV configurations. Figure 2.5 shows the schematic of the power generation and transmission in parallel PHEVs. Figure 2.6 is the schematic of power generation and transmission in series-parallel PHEVs. The well-to-wheel efficiency and emissions of PHEVs are higher than that of fuel-based vehicles (International Energy Agency 2012). The efficiency also depends on the energy source used to create electricity.

Figure 2.5 Schematic of a parallel PHEV

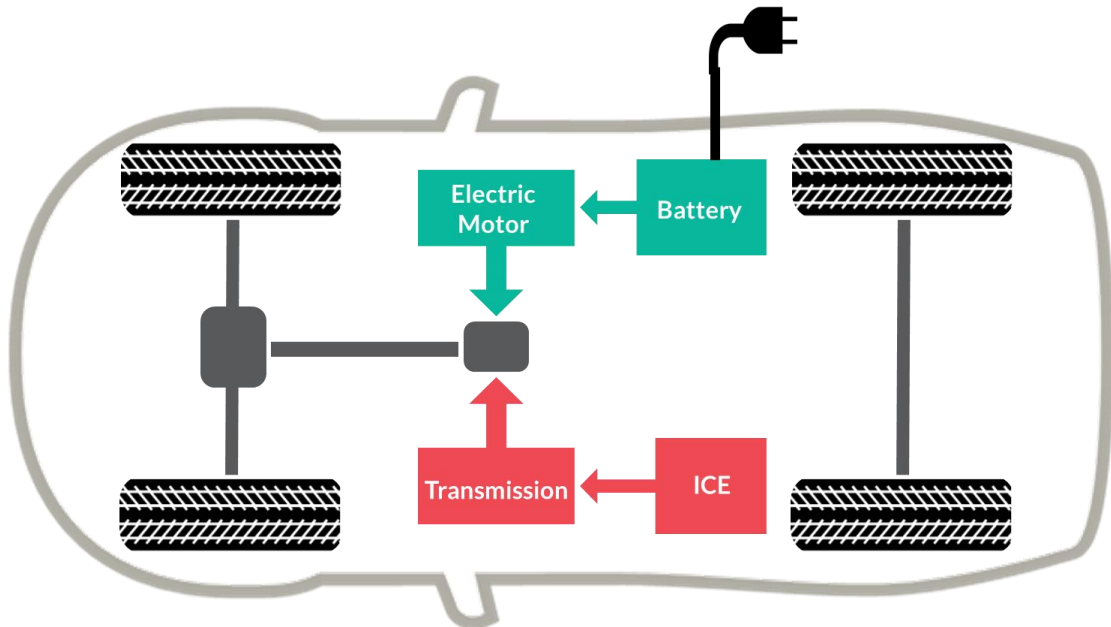

(Environment and Energy Study Institute 2001)(MIT Electric Vehicle Team 2008)(Wroclaw University of Technology 2011)

Figure 2.6 Schematic of a series-parallel (complex) PHEV

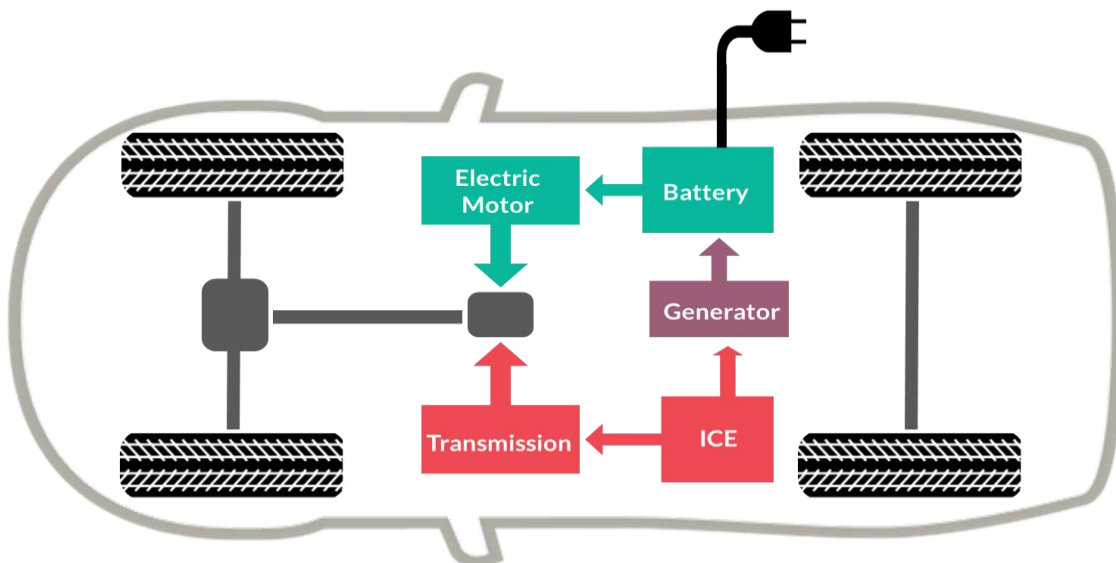

(Environment and Energy Study Institute 2001)(MIT Electric Vehicle Team 2008), (Wroclaw University of Technology 2011)

Table 2.6 Advantages and disadvantages of a PHEV

Advantages	Disadvantages
Small engine size requirement	Big battery pack is required
More reliable than BEVs in terms of range anxiety	Needs charging infrastructure
	More expensive than normal HEVs

(Environment and Energy Study Institute 2001)(MIT Electric Vehicle Team 2008)(Wroclaw University of Technology 2011)

Application of PHEVs: both fast and slow traffic (both intra- and intercity traffic).

In a long-range drive or in constant-speed drive, fuel efficiency does not decrease because the energy from the ICE can be fed directly to the wheels. At slow speeds, i.e., in stop-and-go traffic, energy is not wasted because the “electric-only” mode takes over. Therefore, a PHEV is efficient in both slow and fast traffic. PHEVs can have multiple modes of operations, according to speed and acceleration patterns. It can operate in all modes that normal HEVs operate. Some automobile experts believe that PHEVs will soon become a standard/commercial technology in the automobile industry. PHEVs perform better and store electricity more efficiently using batteries than cars that use hydrogen fuel cells. The traction power efficiency is about 17% in hydrogen fuel cell vehicles and 68% in PHEVs (Wroclaw University of Technology 2011).

The component list includes an ICE propulsion system, an EV propulsion system, battery charging, power accessories, body design and transmission.

The majority of the components are the same as in diesel or CNG buses. Additional components are battery and battery charging-related components such as motor/generator, battery management system, etc.

B. Battery Electric Vehicles (BEVs)

Various types of electric buses have been demonstrated globally. The Trolleybus is a type of electric bus powered by overhead electric lines. The “Gapbus” (another electric bus) is powered by electric lines embedded underground (Wikipedia 2015). This report considers BE buses for analysis. Figure 2.7 provides the schematic of power generation and transmission in BE buses. In a BE bus, the on-board battery provides the entire energy needed for bus operations. Unlike hybrid buses, BE buses have only one energy source in the form of battery and a single energy transmission path. The motor/generator is also used to recharge the battery during deceleration and braking. The battery size and type must be selected to meet the range and power requirements of these buses. BE bus batteries are typically larger than the batteries used in hybrid buses. Therefore, the energy efficiency of the vehicle is very high. With use of clean renewable sources such as solar and wind energy, BE buses would emit minimal quantities of GHGs. Prototypes with on-roof solar Photovoltaic (PV) panels have been attempted; however, the total energy provided by these panels is insufficient to fully charge the battery (Wikipedia 2015).

Figure 2.7 Schematic of BEVs

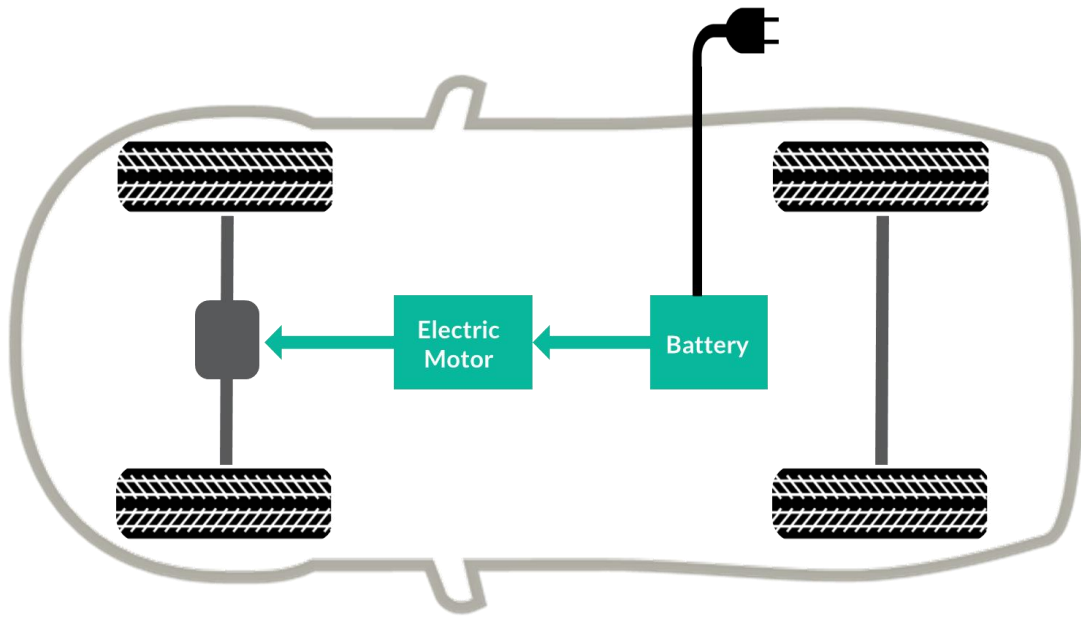

(Delucchi 2001)

Application of BE buses: city-drive conditions.

The current generation of BEVs has a lower range (distance covered in-between charges) due to battery limitations. After the predetermined range is covered, BEVs cannot be refueled in minutes like conventional vehicles; this leads to range anxiety issues. The current charging time is about 5 h for typical BEVs. This limits its long-range transport applications. Therefore, BE buses have better utility in city-drive conditions. State-of-the-art LIBs require significant improvement in relation to energy density to meet the light-weighting aspects of EVs. Moreover, the battery is the biggest component of the total cost of these vehicles.

Table 2.7 Advantages and disadvantages a of BEV

Advantages	Disadvantages
Less expensive than HEVs	Limited range
Zero requirement of fuel	Long charging time
Highest well-to-wheel efficiency	NA

(Delucchi 2001)(International Energy Agency 2010)

Table 2.8 Summarized Comparison of p-HEV, HEV, and BEV

	HEV	pHEV	BEV
Advantages	Battery requirement is small, can be customized for different operational applications, low refueling time	Electricity used from grid, enables higher renewable energy penetration, low refueling time	Electricity used from grid, enables higher renewable energy penetration, highest well-to-wheel efficiency
Disadvantages	No impact on grid dynamics	Large battery is required, high recharging time	Largest battery pack requirement, limited range, high recharging time

According to a study by Aalto University, a diesel bus has more energy distribution losses than an electric bus (Lajunen 2015). Therefore, a BE bus is more efficient in terms of a well-to-wheel efficiency comparison. After considering conversion and transmission losses, electric buses showcase more energy efficiency overall, especially in stop-and-go traffic, where regenerative braking minimizes energy wastes. Table 2.9 represents the quantum of energy losses in diesel and BE buses. The energy consumption of a diesel bus is determined to be 3.64 kWh/km and that of a BE bus to be 1.02 kWh/km (weight of the buses being 14,250 kg) (Lajunen 2015).

Table 2.9 Components and distribution of energy losses in a diesel bus and a BE bus

Category of Losses	Diesel Bus (Wh/km)	BE Bus (Wh/km)
Aerodynamic losses	90	90
Braking losses	370	20
Wheels losses	350	350
Transmission losses	130	270
Ancillary equipment losses	480	270
Engine/battery losses	2,220	20
Total consumption	3,640	1,020

(Lajunen 2015)

BEV also shows much better traction power efficiency than a fuel cell-based EV (Wroclaw University of Technology 2011). Figure 2.8 shows the efficiency losses and the overall efficiency of a Lancer Evolution MIEV, which is a BEV model, and a Mercedes NECAR 3, which is fuel cell-based EV.

Figure 2.8 Efficiency of a BEV (on the left) vs. a fuel cell EV (on the right)

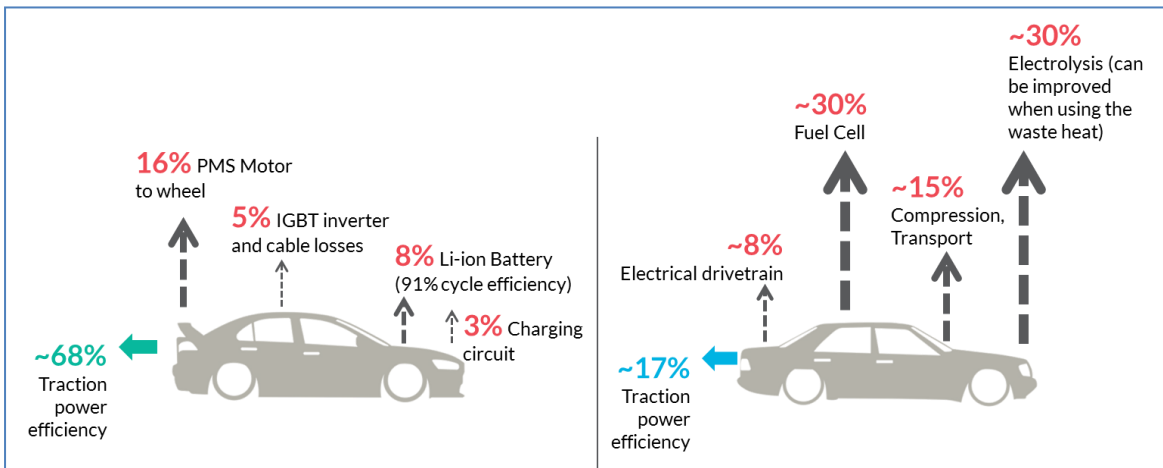

(Wroclaw University of Technology 2011)

BE bus components are divided into four major parts: an EV propulsion system, battery charging, power accessories and body design, which include the following sub-parts:

- Body design – structure, frame, bumpers, suspension
- Electric propulsion system – electronic controller, power converter, motor, transmission, wheels
- Power accessories – brakes, steering, auxiliary supply, temperature control, BMS
- Battery charging – batteries, charger (detailed information is given in further sections).

Figure 2.9 shows the energy flow diagram of a typical BEV. Due to the provision of regenerative braking, the power flow is reversible, i.e., from battery to motor to wheels in the case of acceleration and in the reverse direction in the case of deceleration. The components are represented in various blocks.

Figure 2.9 Schematic of a series-parallel (complex) HEV

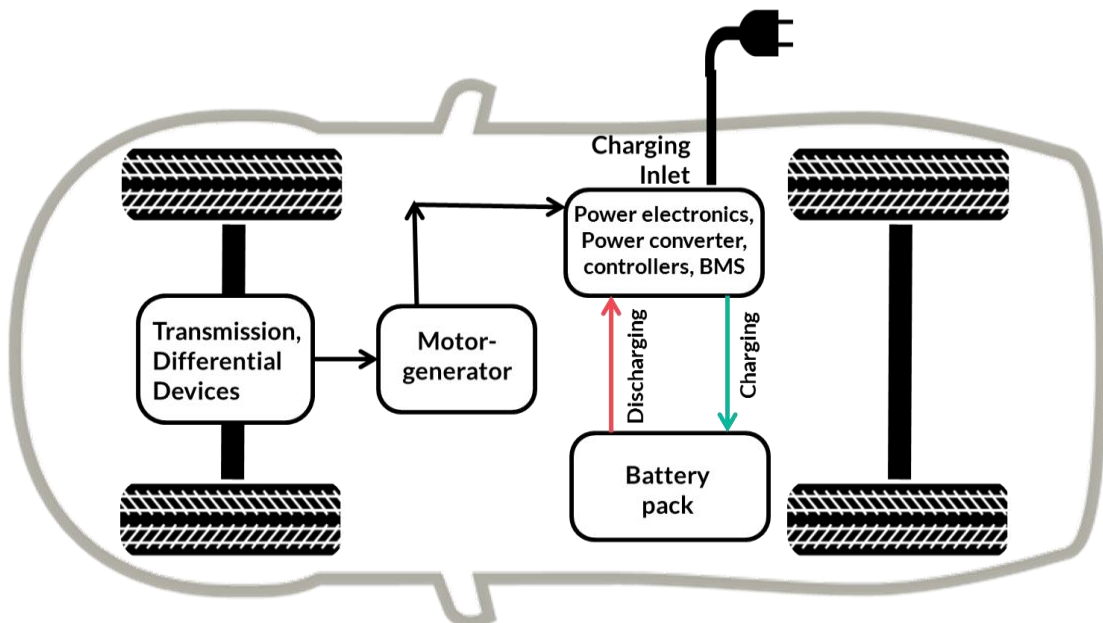

(Chan and Chau 1997a)

Body design – The body design parameters specified by vendors in the specification sheet include length, width, height, wheelbase, turning radius, drag coefficient, rolling coefficient, weight and seating capacity. These concepts are explained in detail in the model-specific comparison in the following section. These parameters are taken into account by the manufacturer to optimize performance and reduce costs. The shape of the bus should be aerodynamic to save energy and attain good speeds. The battery is the heaviest component of the bus and to increase the drive range, heavier battery packs are needed. Therefore, weight savings in other components are achieved through optimized design. Vehicle safety is one of the most important considerations in body design.

Electric propulsion system – Motors are the most important parts of the electric propulsion system. Motors produce mechanical energy from electrical energy to propel the vehicle. The electric motors in the vehicle are also called traction motors. There are two basic types of electric motors – DC induction and Permanent Magnet-based motors (PM-DC).

PM-DC motors do not have windings on the stator. Instead, they use permanent magnets for magnetic field generation. For better performance, high-energy magnets based on rare-earth metals are utilized. Because of the large size requirement of the magnets and the supply vulnerability associated with rare-earth materials, PM-DC motors are becoming unattractive. The most basic type of DC induction motors use brushes to supply electricity to the rotor part of the motor. Brushes are subject to wear and tear, and they need to be replaced periodically. PM brushless-DC motors are being built by inverting the stator and rotor of PM-DC motors to overcome this challenge.

Amongst brush DC motors, brushless DC motors and induction motors, induction motors exhibit the highest efficiencies. Brushless DC and induction motors have longer service lives. The cost of brush DC motors is the least among the three. Further, heat rejection in brush DC motors is the lowest. Therefore, they tend to overheat. In brushless DC motors and induction motors, heat can be controlled with small fans (Dirjish 2012). Both these motors provide constant torque at zero to base speeds. Therefore, they can utilize a single gear ratio. In brush DC motors, torque drops with increasing speed. Therefore, it requires multiple gear ratios for power transmission. As high reliability and maintenance-free operation are prime considerations in EV propulsion, AC induction motors are becoming increasingly attractive. Tesla is using a three-phase AC induction motor in their vehicles (“Roadster Technology,” 2015). DC brushless motors are currently dominating the hybrid market. The induction motors will command high performance from the BEV market. In the future, if HEVs become more electric-intensive, there will be a shift in the market from DC brushless motors to induction motors (Rippel 2007).

According to a report, the total difference in operation costs between a PM-DC motor and a copper rotor induction motor is USD 220–260 (assuming a lifetime of 120,000 miles and 10 years). This cost difference is of little importance in the overall cost of an electric vehicle (Burwell, Goss, and Popescu 2013).

There is a new generation of motors known as the Switched Reluctance Motor (SRM) in which the reluctance torque drives the motor. An SRM has no brushes or permanent magnets. The power is delivered to the stator rather than the rotor. The rotor has no windings or permanent magnets. Therefore, the mechanical design of the motor is less complex than that of an induction motor. The torque is generated from misalignment between the stator and rotor. However, in this type of motor, continuous switching between power receivers makes the electrical design more complex.

Power Accessories: The design of the internal components depends on the o conditions. For example, the design of the traction drive inverter is determined by the application’s specific drive cycle performance needs, which in turn are affected by many variables such as operating temperature, peak and continuous power, size and weight. Performance enhancement in each of the variables increases costs. Thermal management keeps the operating temperature within specified limits for the power electronics, usually by using a liquid coolant and integrated cooling channels (Delucchi 2001)(Chan and Chau 1997a).

The selection of power devices for EV propulsion is generally based on the voltage and current rating requirements, switching frequency, power loss and other battery-related parameters. The voltage rating depends on the battery's nominal voltage, maximum voltage in charging and maximum voltage during regenerative braking. The current rating depends on the motor's peak power rating and the number of electrical devices connected in parallel. The switching frequency depends on parameters like drive cycle and noise level. However, higher switching frequencies increase the switching losses (Chan and Chau 1997a).

Many auxiliary systems are dependent on the main battery pack to supply the necessary power. An auxiliary power converter unit is used to convert the battery power into regulated power for all vehicle accessories, such as power seats, power windows, power locks, brake, vacuum pumps, media systems, windshield, headlamps, interiors lights, air bags, display, etc. Power converters include an insulated-gate bipolar transistor, a static-induction transistor, a static-induction thyristor, etc.(Chan and Chau 1997b). In order to implement modern control strategies, powerful microelectronic devices such as microprocessors, microcontrollers and Digital Signal Processors (DSPs) are necessary. These electronic controllers are part of the power accessories.

Battery: Concepts related to the battery and battery charging infrastructure is explained in detail in Section 2.3.

Model-specific Data

Manufacturer – manufacturers of electric buses can be domestic or foreign. Foreign bus models might cost more than domestic models because of import duties and lack of incentives. Table 2.10 provides a detailed list of important parameters to enable the selection of a particular electric bus model over other models. The parameters are shown in comparison with a standard diesel bus.

Table 2.10 Example of a populated table for a framework of analysis

Segment	Diesel Buses	CNG	Hybrid Electric Bus	Pure Electric Bus	
Model	Volvo 8400 ¹⁶ (AC)	Tata STARBUS SLF 44 ¹⁷ (AC/non-AC)	Tata STARBUS LE CNG 18 ¹⁸ (AC/non-AC)	Tata Starbus Hybrid ¹⁹ (AC/non-AC)	BYD K9 ²⁰ (AC)
Seats	32	44	18	32	31
Length	12.3 m	12 m	12 m	12 m	12 m
Width	2.5 m	2.5 m	2.55 m	2.55 m	2.55 m
Height	3.2 m	3.2 m	3.35 m	3.35 m	3.49 m
Gross weight	16,200 kg	16,200 kg	16,000 kg	16,200 kg	18,500 kg
Costs (INR)	88 lakhs	33 lakhs	30 lakhs	1.2–1.4 crores	2–3 crores
Fuel efficiency	2.2 km/L	3.5 km/L	2–3 km/kg	2.2–4km/kg	1.5 kWh/km
Fuel cost	INR 23/km	INR 15/km	INR 13–19/km	INR 10–17/km	INR 10/km
Range (km)	484	560	260–390	286–520	249
Fuel tank size	220 L	160 L	720 L	720 L	-
Charging time	–	–	–	–	3–6 h
Max power	290 BHP	177 BHP	230 BHP	230 BHP engine 44 kW battery	180 kW
Max torque	1,200 Nm	685 Nm	687 Nm	678 Nm	700 Nm
Battery type	–	–	–	Li-ion batteries	Li-ion Iron (300 kWh)
Emission standard	EURO III	BS III	BS IV	EURO III	Zero tail pipe emission

Assessment Framework Parameters

An assessment framework needs to be built, incorporating these parameters, to evaluate and prioritize the most feasible bus model. These parameters impact the outputs of this framework, which include “total cost of ownership (TCO)” and “operating costs”. Assessing these costs against the primary benefits will give the maximum Return on Investment (ROI). Primary benefits are in the form of revenues. Furthermore, such a framework can be utilized to compare diesel buses with electric buses. Additional returns need to be estimated from secondary benefits. Secondary benefits consist of emission and noise reductions, energy security, etc. For the calculation of secondary benefits, parameters related to noise, emissions and energy security will be needed. Additionally, the framework should have a sensitivity analysis component embedded in its overall structure.

It is to be noted that this compilation does not include emission-related parameters, since an electric bus is a zero-(local)-emission vehicle. The emissions that are associated with an electric bus come from the fuel burnt to produce electricity for charging. In power plants, fuel is burnt more efficiently than in ICs, and, therefore, the overall fuel efficiency is more in an electric bus than a diesel bus(Nils-Olof Nylund, n.d.)

All these parameters are listed in Table 2.11.

¹⁶(“Volvo 8400 LF, ₹ 71,84,000” 2015).

¹⁷(“Tata Starbus SLF 44” 2015).

¹⁸(“Tata Starbus LE CNG 18, ₹ 30,17,000” 2015).

¹⁹(“Tata Starbus CNG Electric Hybrid (LF/32),” n.d.).

²⁰(“BYDAuto” 2015).

Output parameters

Total Cost of Ownership (TCO) – this value is the Present Value of all future expenditure. TCO is equal to the Present Value of capital cost plus the Present Value of operating costs. The major cost components of TCO are fuel/electricity cost, maintenance cost, depreciation, interest cost, salvage value, etc.

Operating Costs (OCs) – the major cost components of OCs are fuel/electricity cost, maintenance cost, labor costs, etc.

Manufacturer – manufacturers of electric buses can be domestic or foreign. Foreign bus models might cost more than domestic models because of import duties and lack of incentives.

Body design parameters

Length – the length of a bus determines its turning radius. For instance, in mountainous regions, long vehicles might not be feasible due to the smaller turning radii of the roads. This parameter is dependent on the terrain data of the bus route and should be considered in the assessment framework.

Width – wide vehicles might not be feasible in areas that have narrow roads. Width value relates to the terrain data of the route in the assessment framework.

Height – low clearance especially in mountain roads due to trees and rocks might hamper the movement of tall vehicles. Height value relates to the terrain data of the route in the assessment framework.

Wheelbase – wheelbase is the distance between the centers of the front and rear wheels. It is correlated with the length of a bus and other design factors. The wheelbase of a bus determines its turning radius. Wheelbase value relates to the terrain data of the route in the assessment framework.

Turning Radius – in hilly terrains, vehicles with greater turning radii might not be feasible due to the sharp turning angles of the roads. The turning radius value relates to the terrain data of the route in the assessment framework.

Drag Coefficient – the drag coefficient is the aerodynamic property of the bus and is dependent on the body design. It affects the movement and stability of the vehicle at higher speeds, typically above 50 kmph.

Rolling Coefficient – rolling coefficient is related to the friction of the tires. At high altitudes, better friction is required on the roads during snowfall. However, in urban areas, for a bus with the same rolling coefficient, good roads and the absence of snowfall will lead to better performance.

Maximum Gradeability – this specification is calculated based on engine power, maximum output, and maximum torque of engine and kerb weight. Maximum gradeability is the maximum angle of slope the vehicle is able to climb.

Weight – gross vehicle weight is equal to the carrying capacity (freight and passengers) plus the empty vehicle's weight. The gross vehicle weight will determine the energy requirement and operating costs, while the gross axle weight rating will indicate the maximum weight that is supported by the axle.

Seating Capacity – higher seating capacity translates into higher revenues. This quantity is important to determine the demand-and-supply equilibrium for traveling.

Engine Parameters

Maximum Power – maximum power refers to the quantum of power that can be drawn from the diesel engine or battery in the case of electric buses. However, the battery is never operated at maximum power because of safety requirements and the life of the battery. Limits on power rating are usually set by the manufacturers to protect the battery system and optimize the design of systems.

Rated Power – rated power is the maximum power at which a battery can be operated. It is less than the maximum power rating of the battery. Manufacturers provide a level of operating power under which the equipment will not be damaged while allowing a certain safety margin. This terminology is usually not used in diesel buses. The Rated Power value relates to the terrain and drive cycle of the route.

Maximum Torque – maximum torque is a measure of the work done by the energy used in rotating the output shaft. This value relates to the terrain and drive cycle of the route in the assessment framework. If the terrain has lot of slopes, a higher torque will be required.

Top Speed – it is the maximum speed a vehicle can attain. However, very high speed lowers the battery efficiency (km/kWh), which reduces the ROI. High power is withdrawn from a battery to achieve higher speeds, which causes capacity fading in the battery, especially in the context of highway-driving conditions.

Bus Mileage – for diesel buses, mileage is measured in kilometers per liter. For electric buses, mileage is measured in kilometers per kWh. It is also called battery efficiency. A higher mileage improves the ROIs.

Diesel Tank Capacity and Battery Storage Capacity – these capacities will determine the range of the vehicle. The product of capacity and mileage is called range. In the case of electric buses, a higher battery capacity will increase the capital cost of the vehicle. However, fewer charging cycles due to higher battery capacity might improve the economy of the bus. The battery pack design should be optimized over the cycle life of a battery, drive cycle, charging time and depth of discharge.

Operating and cost parameters

Bus Life – the service-life policies for diesel and electric buses are different. The service life of electric buses is longer because of less moving components as compared with those in diesel buses. A higher service life will increase the ROI and decrease the TCO.

Price – the price of the bus has a direct correlation with TCO and returns. Currently, the price (and therefore the depreciation component) is the biggest factor of the TCO. In diesel buses, fuel costs are the biggest cost components in the TCO.

Maintenance Rate – maintenance cost is one of the major components in the operating costs. It depends on the maintenance requirements of the moving parts, cleaning of the bus, replacement of components, labor and garage space. This is expressed in “INR/ km”.

Annual Maintenance Cost – annual maintenance cost is a product of maintenance rate and annual distance traveled.

Additional Cost to Refuel (for diesel bus) and Additional Cost to Recharge (for electric bus) – additional costs associated with gas/charging stations include space, infrastructure and labor. This will increase the TCO. It is one of the cost components.

Distance Traveled Per Day – this represents the distance traveled by the bus per day in the drive cycle data. Longer distances traveled might require the battery to be charged more often. Also, more distance will contribute to more operating costs. Therefore, this value has to be optimal with regard to battery capacity to maximize returns.

Working Days per Year – it is the number of days the bus is in operation. For a few days every year, conditions will be too extreme to operate the bus, e.g., heavy rainfall, heavy snowfall, extreme temperatures, etc. Lower working days per year reduces revenue.

Annual Distance Traveled – annual distance traveled is the product of distance traveled per day and working days per year. It impacts the operating cost and return calculations. The total fuel or electricity requirement is also calculated from this value.

Range – range will determine the distance covered by the vehicle before refueling or recharging. In the case of diesel buses, the refueling time is small compared with the running time. Recharging time is very high in electric buses. A long-range vehicle costs more (due to higher battery capacity); therefore, the range should be optimized according to drive cycle and other relevant parameters.

Refueling Time and Recharging Time – in an electric bus, the recharging time is very high. In the case of diesel buses, however, the refueling time is small compared with the running time. For diesel buses, time optimization is, therefore, not important.

Diesel Price and Electricity Price (for Electric Buses) – there is a direct relationship between operating cost and price of diesel or electricity. The fuel cost is more than 50% of the TCO of a diesel bus. Similarly, electricity cost is about 10%–15% of the TCO in the case of electric buses.

Annual Diesel Demand and Annual Electricity Demand – the annual diesel demand is obtained by dividing the distance traveled per year by the mileage of the bus.

Annual Cost of Diesel Fuel and Annual Cost of Electricity – this value will determine the TCO and operating costs. It can be calculated from the distance traveled per year and the diesel cost or electricity tariff.

Diesel Inflation Rate and Electricity Inflation Rate – inflation rates are different for diesel and electricity. Electricity is seen as a stable-growth commodity and diesel is seen as a volatile commodity; i.e., diesel shows more price fluctuations. Inflation rates will have a direct impact on the TCO and operating costs. Historically, the price of diesel has grown faster than the price of electricity. Over a longer service life period, the TCOs for electric buses can be lower than those of diesel buses. Inflation is one of the most important factors in sensitivity analysis.

Discount Rate – this value can be taken as the general discount rate considered in vehicle industry investments or it can be taken as the interest rate on vehicle loan. It is the most important financial parameter to calculate the TCO and returns, and to perform a sensitivity analysis.

Table 2.11 Diesel and electric bus key parameter comparison

Bus	Diesel	Bus	Electric
Manufacturer	TATA ²¹	Manufacturer	BYD ²²
Model	LPO 1512	Model	2013 BYD 40ft
Body Design Parameters		Body Design Parameters	
Length	10,772 mm	Length	12,267 m
Width	2,600 mm	Width	2,550 m
Height	3,250 mm	Height	3,486 m
Wheelbase	5,545 mm	Wheelbase	6,250 m
Turning Radius	-	Turning Radius	12,781 m
Drag Coefficient	-	Drag Coefficient	-
Rolling Coefficient	-	Rolling Coefficient	-
Maximum Gradeability	-	Maximum Gradeability	28%
Gross Weight	16,200 kg	Gross Weight	18,500 kg
Seating Capacity	59	Seating Capacity	40
Performance Parameters		Performance Parameters	
Maximum Power	99 kW	Maximum Power	360 kW
Rated Power	-NA-	Rated Power	300 kW
Maximum Torque	490 Nm	Maximum Torque	3,000 Nm
Top Speed	90 km/h	Top Speed	101 km/h
Acceleration	-	Acceleration	0–50 km/h in 20s
Bus Mileage	3 km/L	Bus Mileage	0.67 km/kWh
Diesel Tank Capacity	250 L	Diesel Tank Capacity	324 kWh
Operating and Cost Parameters		Operating and Cost Parameters	
Service Life Of Bus	10 years	Service Life Of Bus	NA
Price	INR 20 lakhs	Price	NA
Maintenance Rate	NA	Maintenance Rate	NA
Annual Maintenance Cost	-	Annual Maintenance Cost	-
Labor Cost to Refuel	-	Cost to Recharge	-
Distance Traveled per Day	-	Distance Traveled per Day	TBD
Working Days per Year	-	Working Days per Year	TBD
Annual Distance Traveled	-	Annual Distance Traveled	TBD
Range	750 km	Range (between Charges)	249 km
Refueling Time	15 min	Recharging Time	5 h (at 480 V)
Diesel Price	INR 60/L	Electricity Tariff	INR 6.95/kWh
Annual Diesel Demand	-	Annual Electricity Demand	TBD
Annual Cost of Diesel Fuel	-	Annual Cost of Electricity	TBD
Diesel Inflation Rate	9%	Electricity Inflation Rate	3%
Discount Rate	10.25%	Discount Rate	10.25%
		Life of Battery type	3 years

²¹(TATA Motors, n.d.).

²²(BYD Auto 2015).

2.3 Battery and Charging Infrastructure

Storage for Electric Transportation: Battery

The batteries used in EVs need to have high energy density due to automotive light-weighting requirements. This means they should be able to store more energy per unit volume or weight of the battery. This is crucial for attaining higher range (mileage) per charge without having to bear enormous battery weights. Hence, the EV battery type and design differ from those used in grid applications (because they are stationary); the battery pack does not have to be light-weight. Other important parameters for a battery technology to qualify for EV applications include reliability, long cycle life, low cost and safety. Since it is difficult to find all these features in a single battery system, the typical practice is to optimize the performance mix as per the EV variant.

Description of battery parameters and concepts

This section briefly discusses the performance parameters of various battery systems in the context of EVs (Linden and Reddy 2002). The choice of battery materials depends greatly on the EV segment that is being targeted. For instance, in an “all-electric” vehicle, the challenge is to increase the driving range between two battery charges. This applies to PHEVs as well since the aim is to always have a higher range in the “battery mode” of operations. This mandates the use of electrode materials that have high charge-storing capability. A higher cell voltage is desired for achieving greater specific energy or energy per unit mass of the battery. Open-Circuit voltage (OCV) is the voltage when there is no net current flow (in the absence of load). The voltage of a battery under load (when drawing current) is lower than the OCV. Hence, there has always been an effort to keep innovating and improving the existing electrode materials’ chemistries to achieve higher operating voltages. This helps in meeting the stringent EV performance targets and regulatory specifications.

Further, it is not enough for an electrode material to just display higher energy density or higher charge storage capability; it is equally important to maintain this parameter consistently over a significant number of charge–discharge cycles, which translates into higher battery life. This is critical due to cost implications as well since the battery component cost is the maximum among all EV components. Hence, the materials used in the electrode fabrication are required to have high stability, and should retain their structure and properties over a prolonged period. These should also be resistant to the chemicals and materials used in fabricating electrolytes and battery pack casing, container, etc. All this needs to be achieved keeping the material cost in mind for a successful deployment roadmap.

Battery safety is yet another important battery parameter. Automotive vehicle and passenger safety standards are quite stringent and any failure to meet these results in massive vehicle recalls. For instance, in the case of LIBs, the state-of-the-art electrolytes used in various LIB variants can at best withstand a voltage window of about 5 V. If at any given time the voltage exceeds this tolerance limit, the battery runs the risk of catching fire or exploding since the LIB electrolytes are highly flammable. Thus, having a higher voltage tolerance is one of the many requirements that an electrolyte must fulfil to be commercially successful. In this context, there have been continuous attempts to find novel electrolyte materials that are best optimized solutions for handling high-voltage electrode materials in emerging battery variants.

In addition, the electrolyte should be chemically stable with respect to the electrodes. It is crucial for the electrolyte to be able to form a passivating Solid–Electrolyte Interface (SEI) protective layer, which provides chemical stability at high discharge rates, which prevents unwanted side reactions. Besides these, low cost and low toxicity are other desired features.

Battery Technologies for EV

Keeping all these desired parameters in mind, the following two rechargeable battery classes have so far been successful for EV applications:

- I. Nickel (Ni)-based aqueous batteries
- II. Lithium-ion batteries.

Although lead-acid batteries have been most successful in conventional fuel vehicles due to their low cost and safe operations, their main drawback is the low energy density. As mentioned above, the battery weight has to be less to maximize mileage between consecutive charges. In other words, a heavier lead-acid battery pack will be required to store the same amount of charge as compared with a Ni-based or LIB system, which display significantly higher energy density. Hence, although lead-acid batteries are feasible for the starting–lighting–ignition needs of petrol/diesel based vehicles, they do not qualify for applications in the EV segment.

I. Ni-based aqueous battery system

These batteries are mainly made up of nickel cadmium (Ni–Cd), nickel zinc (Ni–Zn) and nickel–metal hydride (Ni–MH). The cathode in all these variants is nickel hydroxide and these have potassium hydroxide as the electrolyte. The anode is different in the above systems and is Cd, Zn and a complex metal alloy (a mix of rare earths, nickel, zirconium, aluminum, etc.), respectively. Ni–Cd provided an improvement over lead acid, but due to the toxicity of Cd, these are being phased out globally. The Ni–MH battery shows improvement over Ni–Cd in terms of higher specific energy, longer cycle life and higher discharge rate features besides being environment-friendly, but shows poor performance below 0°C operating conditions. In addition, the shelf life of the battery is low due to high self-discharge when not in service. A Ni–Zn system displays good performance in terms of cell voltage, charge storage capacity and high rate discharge capability, but suffers from growth of dendrites on the Zn anode during cycling. This causes internal short-circuits and material loss (and, hence, storage capacity) over time. These were the main motivating factors for the innovation and emergence of LIB, which overcomes most of these disadvantages.

2. Lithium-ion battery (LIB)

LIBs are currently the most widely used battery system in EVs (Nazri and Pistoia 2004). These batteries display high voltage, reliable discharge at a high rate and a good cycle life. It has a cathode, which is a compound of Li and transition metal oxides (or phosphates) (Eliis and et al 2010), an anode, which is mostly carbon-based, and electrolyte made up of organic solvents with Li salts.

Discovery of high-voltage-compatible electrolyte materials is crucial for safer application and better performance of batteries at high voltage windows. There are newer high-voltage candidates for cathode materials, but due to electrolyte stability issues beyond 4.8 V, the favorable chemistry of these cathodes remains under-exploited. Discovery of high-voltage-compatible electrolyte materials is hence crucial as explained earlier in this section. In addition, new safer cathode chemistries have to be optimized as the high inherent oxygen partial pressure in the popular oxide-based cathodes can result in explosions. This issue was highlighted in recent battery-related fire incidents in a Chevy Volt electric car and a Dreamliner aircraft. At present, phosphate-based cathode chemistries (e.g., lithium iron phosphate cathode) are preferred over their oxide-based variants due to the higher safety features despite having lower operating voltage. The cathodes cost high due to the presence of lithium. In many battery technologies, anode is the less expensive component. The electrolytes are a mixture of organic solvents like ethylene carbonate/dimethyl carbonate, etc., and contain dissolved salts of lithium (e.g., LiPF₆). The major challenges in the LIB system are the lower safety and high costs. Table 2.12 provides a summary of various battery systems.

Table 2.12 Summary of various battery systems with composition and performance characteristics

System	Cathode	Anode	Electrolyte	Energy Density Wh/kg	Cycle Life	2014 Price per kWh (in USD)	Prominent Manufacturers
LIB (3.2V)	Lithium iron phosphate	Graphite	EC, DMC	85–105	200–2,000	550–850	A123 Systems, BYD, Amperex, Lishen
LIB	Lithium manganese spinel	Graphite	EC, DMC	140–180	800–2,000	450–700	LG Chem, AESC, Samsung SDI
LIB	Lithium iron phosphate	LTO	EC, DMC	80–95	2,000–25,000	900–2,200	ATL, Toshiba, Leclanché, Microvast
LIB	Lithium cobalt oxide	Graphite	Lithium polymer	140–200	300–800	250–500	Samsung SDI, BYD, LG Chem, Panasonic, ATL, Lishen
LIB	Lithium nickel cobalt aluminum	Graphite	EC, DMC	120–160	800–5,000	240–380	Panasonic, Samsung SDI
LIB (3.6V)	Lithium nickel manganese cobalt	Graphite, silicon	EC, DMC	120–140	800–2,000	550–750	Johnson Controls, Saft
Ni–MH (1.2 V)	Nickel hydroxide	Metal hydride	Potassium hydroxide	70–80	500–2,000	500–550 (2013 cost)	Ovonic Battery, GS Yuasa
Ni–Cd (1.2 V)	Nickel hydroxide	Cadmium	Potassium hydroxide	40–60	Up to 2,000	NA	AMCO SAFT
Advanced Pb-acid (2 V)	Lead oxide	Lead	Sulphuric acid	33–42	500–800	250	Exide, AMCO, YUASA

EC: Ethylene Carbonate, DMC: Dimethyl Carbonate

(IRENA 2015); LIB data based on (Jaffe and Adamson 2014); Ni-MH, Ni-Cd and Lead acid battery data based on (Linden and Reddy 2002)

Battery Management System (BMS)

A battery functions optimally within certain operating windows of temperature, voltage, structural changes (during charge–discharge) and few other parameters. These operating windows are specific to each battery system.

In the case of electric vehicles, LIB has been the frontrunner in recent years and will continue to be so in the foreseeable future. However, due to inherent features, it is also prone to safety and performance failures if at any time the operating windows are violated. The operating temperature windows for the majority of automotive-grade LIB variants, e.g., with LMO, LFP cathodes, are (1) discharging between -20°C and 55°C , and (2) charging between 0°C and 45°C . The operating voltage is within 1.5–4.5 V. In fact, the most common LIB variant for EVs is LFP, which operates between 2 and 3.7 V. At higher temperatures, the battery runs the risk of decomposition of electrolyte and electrode materials. Decomposition of cathode materials produces oxygen gas and that of electrolytes produces combustible gases, which react with oxygen to cause fire or explosion. This is called the *thermal runaway of the battery*. Moreover, if the temperature falls below the operating window, the diffusivity of Li ions decrease and it results in the underperformance of the battery. Another cause of underperformance is the structural change that happens in case the battery is over-discharged beyond its tolerance limit. In this scenario, the material undergoes a phase change and, hence, displays a voltage that is different (much lower) from what is claimed by the manufacturer and, hence, is not acceptable for the target application. These conditions cause safety hazards and have resulted in several vehicle recall episodes in the past. Hence, battery researchers and developers are always trying to invent safer and better-performing battery systems to satisfy the stringent automotive performance and safety regulations. This is one approach to address the challenges mentioned above. A parallel approach is to install a BMS (Andrea 2010; Enhua 2011; UNECE, n.d.) That ensures that each cell in the LIB pack or module (cluster of several LIB cells) functions within the various operating windows. The BMS enables real-time monitoring and control of LIB cells within a battery pack. A BMS is crucial for the safety and long operational life of the battery component of a vehicle, especially in the case of all-electric buses as they need large battery capacity.

Components of BMS: Among the various components of a BMS, the sensors, actuators and controllers play important roles. The sensors detect and control the main current and voltage in the circuit to help manage the cells within the optimum windows. This in turn assists in managing the depth of discharge. As described above, this is important to prevent the voltage from falling below the tolerance limit. Similarly, the voltage sensors also keep the cell from overcharging, which can lead to a fire episode or explosion. The temperature sensors measure temperature at various locations within the cell and also outside each cell and module, and thus prevent the decomposition of electrodes and electrolyte. In addition, the BMS includes an embedded software network that estimates and manages the battery's State of Charge (SoC), On-Board Diagnosis (OBD), battery safety control/alarm, battery operating parameters, battery equalization (to maintain consistency between all cells within a module), information storage and thermal management. The BMS has to be fully adaptable to the complex electromagnetic environment of the electric vehicle. This is essential for vehicle safety and reliability.

Charging Infrastructure: Technology Landscape

This section presents an overview of the concepts and infrastructure related to battery charging that are needed for an EV fleet. Plug-in EVs like PHEVs and BEVs require physical connections with Electric Vehicle Supply Equipment (EVSE) at the charging station. On the other hand, HEVs are charged using regenerative braking and an ICE. As explained in a previous section of this chapter, the regenerative braking system converts a vehicle's kinetic energy into electric energy, which charges the battery. In conventional vehicles, this energy gets wasted as heat. HEVs do not require external charging equipment like EVSE.

It is important to set up a robust charging infrastructure to enable large-scale penetration of plug-in EVs of all types keeping in mind the huge NEMM targets. The EV market is expanding globally due to governments

promoting/boosting clean transportation as a policy (incentivizing EV manufacture and purchase). According to a research report (“Electric Vehicle Market Forecasts: Global Forecasts for Light Duty Hybrid, Plug-In Hybrid, and Battery Electric Vehicle Sales and Vehicles in Use: 2014-2023” 2014), plug-in EVs will constitute 2.4% of the global light-weight vehicle fleet by 2023.. The electric bus market is forecast to grow at a CAGR of 28% and reach approximately 34,000 units by 2020 (“Global Market Study on Electric Bus: Asia Pacific to Witness Highest Growth by 2020” 2015). As a consequence, the share of EV-Charging (EVC) stations is expected to grow from more than 1 million units in 2014 to more than 12.7 million units in 2020 (Business Wire 2015).

Charging Technologies

Batteries provide power to EVs through electrical energy as a result of chemical reactions. Charging involves the conversion of electrical energy into chemical energy and is a way to store electrical energy in the batteries.

There are two types of charging technologies:

Conductive charging

Conductive charging requires a physical connection between the EV and EVSE at the charging station. This technology has been historically the most popular option for accessing grid electricity for various charging applications. The automotive standard voltage plugs and sockets interface between the distribution lines and the on-board sockets. All battery systems currently use the conductive charging technology (Figure 2.10).

Figure 2.10 Schematic of an electric bus showing battery and electrical layout

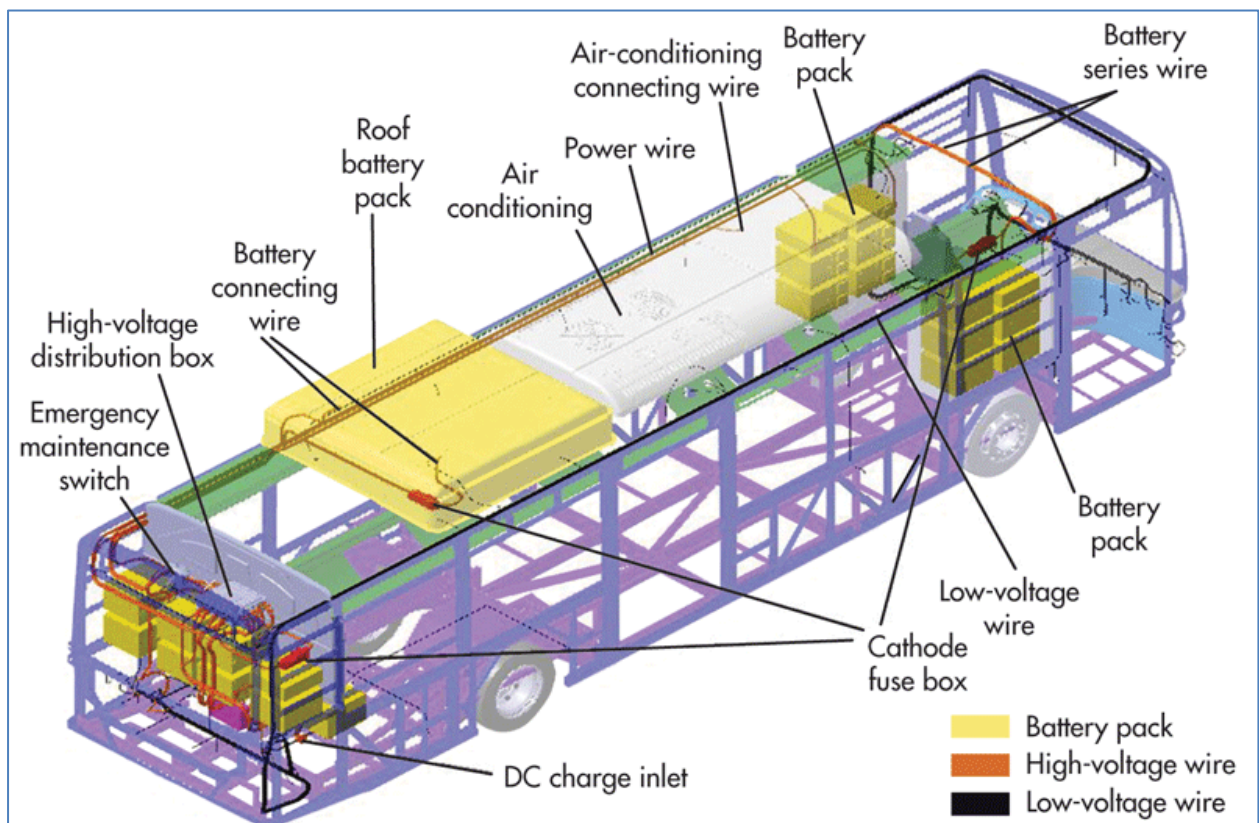

(Austin 2013)

Inductive or Contactless charging

This is a relatively new technology that has emerged in recent years (Nizam 2013). Inductive charging uses an electromagnetic field to enable the exchange of energy between the EV and the charging station. In this method, no physical contact is needed between the energy source and the vehicle. Inductive charging works by using an induction coil placed within a charging station to create an electromagnetic field. A second induction coil, placed on the EV, takes power from the electromagnetic field and converts it into an electrical current that is used to charge the on-board battery.

The advantages of such wireless charging systems include safety (no exposed conducting surfaces, hence no electric shock), no cable needs, high reliability, low maintenance (automatic, minimum intervention required), reduced risk of theft and long product life due to less wear and tear. Figure 2.11 shows an induction charging schematic of a prototype all-electric bus introduced in London in 2015.

Figure 2.11 Inductive charging in an electric bus

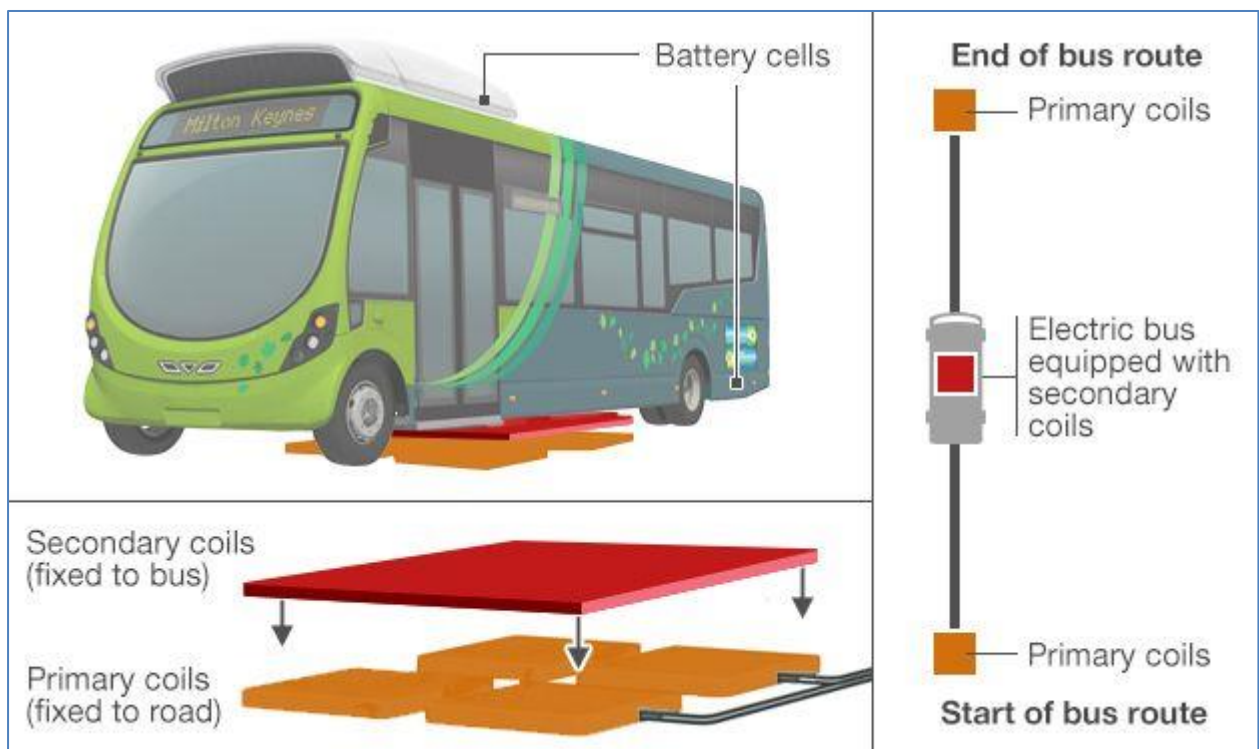

(Science, Reporter, and News 2015)

Table 2.13 lists the pro and cons of both these technologies.

Table 2.13 Comparison of conductive and inductive charging technologies

Parameters	Conductive Charging	Inductive Charging
Installation cost	Low	High*
Maintenance cost	High	Low**
Safety	Low	High***
Lifetime	Low	High**

Parameters	Conductive Charging	Inductive Charging
Efficiency	Very high (above 95%)	80%–90%
Reliability	Low	High**

*Installation cost—high due to power electronics components.

** No exposed conductors, no contacts between the surfaces of the EV and the charging point, and, hence, no wear and tear.

*** No exposed conductors, hence a lower risk of electrical shock.

In January 2015, eight electric buses were introduced in England utilizing inductive charging as per the method shown above. Inductive charging has several advantages over conductive charging. It is easy to operate due to heavy automation. The driver does not have to exit the vehicle to start the charging as there are no connectors or cables involved. Inductive charging safeguards the vehicle from thefts, abuse and severe environments as all charging components are encapsulated in the vehicle or under the ground. However, the cost is significantly higher than that of conductive charging (Science, Reporter, and News 2015).

Types of Charging and Battery Swapping

The time taken to charge a battery is an important issue for the larger adoption of EVs and is a crucial factor in making decisions regarding charging methods as well as EV route selection. The charging time depends on the charging methodology and also on the battery type, storage capacity and size. Opting for a reduced charging time increases costs due to several associated factors like usage of more expensive battery variants that are made up of materials having higher charge storing capacity, and more efficient and sophisticated charging techniques. Hence, the method of charging should be decided by considering the application needs after doing a thorough techno-economic feasibility analysis.

Types of charging: EVC stations can be either an AC- or DC-based system. An AC charging station supplies electricity to the on-board vehicle charger, which transforms the AC from the electric grid into DC, which is used for charging the vehicle battery pack. Since India does not have a significant EV fleet and the standards are still evolving, this section will discuss this aspect keeping the US market and the Society for Automotive Engineers (SAE) guidelines as the points of reference. An AC (much lower voltage and currents than that in DC charging; maximum continuous input power <8 kW) charging station provides 8–25 km of electric range per 30-min charge, whereas a DC (very high voltage and current; maximum continuous input power 240 kW) charging station supplies current directly to the vehicle battery and typically provides about 125 km of electric range per 30-min charge (Business Wire 2015).

Battery Swapping: Battery swapping refers to the replacement of a discharged battery with a charged battery. The stand-by charged batteries at the swapping centers are not owned by the vehicle owners; these are leased or rented out. This practice is gaining popularity due to quick turnaround. However, swapping is expensive due to the requirement of an increased number of stand-by batteries and a huge space for their storage, and the need for sophisticated equipment such as robots at the service stations for handling a high volume of swapping operations.

A short description of the types of charging, advantages and disadvantages is given in Table 2.14.

Table 2.14 Comparison among types of charging and battery swapping

Type of Charging	Charging* Time	Advantages	Disadvantages	Segment
Slow (220 V, 13 A)	24 h	Easy to implement	Slow	Private cars, two-wheeler

Type of Charging	Charging* Time	Advantages	Disadvantages	Segment
Fast (220 V, 32 A)	12 h	Moderate, flexibility of a single phase or three phases	More investment	Public cars, public buses
Rapid (50 kW+)	90 min	Fast	Restricted to three phases, high cost, loading issue, low efficiency	Public buses, public cars
Battery swapping	2–5 min	Very fast	Cost of battery, space requirement at EVCPs, robotics	Public buses

*Charging time is the time taken to fully charge the completely discharged battery and it is calculated for a battery capacity of 70 kWh.

Charging time (h) = Battery capacity (kWh)/Power (kW) * η ,

where power = voltage (v) x current (i);

η is charging efficiency.

The assumed efficiencies are 96% and 81%, respectively, for slow and fast charging.

Components of a charging point system

Power is delivered to a vehicle's battery through an on-board charger. The EVSE (or the charging station) draws electric power from the grid and through the EV inlet, and supplies power to the charger. The charger and EV inlet are hence an integral part of the EV energy pathway.

Components of conductive charging: Conductive charging components consist of connector, an electrical connection cable, and power supply from the utilities or grid in addition to the GPRS to locate charging stations. A connector is a device that establishes a connection between the electrical circuits and the EV for the purpose of charging the battery. One of the international standard connectors is shown in Figure 2.12.

Figure 2.12 SAE J1772 2009 EV connector



(“SAE J1772 - Wikiwand” 2015)

The electrical connection cable for EVs is fitted with plugs at either end to be inserted into the EV inlet and get plugged into the charging point (Figure 2.13). This is normally supplied at the charging station as per the type of EV to be serviced. The EVSE operators follow the international standard power circuit wiring color code to comply with the safety norms. These cables are designed to withstand extreme temperature, weather and wet conditions, and are chemical-, oil- and impact-resistant.

Figure 2.13 EV connection cables



(“Guidance for Implementation of Electric Vehicle Charging Infrastructure” 2010)

Components of inductive or contactless charging: Since this technology needs no physical connections between EVs and charging points, there is no requirement of connectors and connection cables. The components needed in this case, besides the induction coils, include a local electricity distribution network connection, GPRS to locate charging stations, a charging point display to monitor the state of charge of the battery or the energy consumed, and an access tag in case of a restricted-access consumer model. In this method, smart controllers take care of the charging process with minimum human intervention.

EV charging: Impact on Grid

How the Grid works: An electricity grid consists of a mix of different types of power plants along with the transmission and distribution network. The power plants are the generating elements of the grid and operate to meet the base load and peak demand of a region. The base-load power plants, like coal plants, operate continuously to meet the minimum load and are cost-effective. The peaking plants, like hydro and gas-based plants, on the other hand, are operated during peak-demand hours and, hence, are costly. Unlike the base-load power plants, the peaking plants have the advantage of having a quick response time and can be turned

on and off at short notice. The peak-load profile of a region determines the total installed capacity required to serve that area, whereas the hourly load is met with the most optimal mix of power plants; it could be just the base-load plants or these along with a few peaking generators.

Impact of EV charging on Grid infrastructure: The number of EV buses within a bus fleet would to a significant extent determine the charging requirements, which in turn would determine the energy requirement and additional power plants (if necessary). An analysis of load profile can show whether some plants that are not being used during off-peak hours can fuel the EV fleet. Some loads like consumer (residential and office) electricity demands are instantaneous and need to be catered to in real-time. However, an EVC schedule can be controlled since the vehicle travel time is temporally separate from the time of battery charging. Typically, electric vehicles are charged most economically during off-peak hours and preferably using base-load plant supplies. This will keep the electricity cost low (Hadley and Alexandra 2008).

The other scenario could be if a large EV fleet is to be charged during peak-load hours. This will require the addition of new generators and will involve considerable infrastructure investment. A thorough grid supply-and-demand analysis will need to be carried out along with EV fleet economics to arrive at the optimum plant mix for a particular region. Typically, the practice is to match the EV recharge demand with base plants.

To summarize, before an EV fleet is added to an area, a detailed sub-station- and feeder-level study should be done to assess the local distribution network capacity and congestion probability due to recharging needs and patterns. The benefits provided by the EV adoption need to be determined keeping in mind the overall regional grid profile and electric transport policy landscape.

3. Impacts and Benefits

3.1 Air Quality

India is the fourth largest GHG emitter in the world (International Energy Agency 2015). The transport sector is one of the largest emitters of GHG and contributes 7.5% of the total national CO₂e emissions (2007) (Indian Network for Climate Change Assessment 2010). It contributed about 142 Mt of CO₂e emissions in 2007 as against 80 Mt in 1994. Road-based transport contributes about 87% of the total transport emissions. According to a report prepared by the Task Force on National Greenhouse Gas Inventories of the Intergovernmental Panel on Climate Change (IPCC), GHG emissions (from the transport sector) due to fuel combustion include carbon dioxide (CO₂), methane (CH₄) and nitrous oxide (N₂O), and pollutants such as carbon monoxide (CO), Non-Methane Volatile Organic Compounds (NMVOCs), sulfur dioxide (SO₂), PM and oxides of nitrate (NO_x) (Inter Governmental Panel for Climate Change 2006).

The Central Pollution Control Board (CPCB) classifies PM_{2.5} to be composed mainly of carbonaceous materials (organic and elemental), inorganic compounds (sulfate, nitrate and ammonium) and trace metal compounds (iron, aluminum, nickel, copper, zinc and lead). Exposure to high levels of air pollutants can have adverse health impacts. Of all the other ambient air pollutants, the health impacts of PM_{2.5} (particles of size less than 2.5 μm) are more significant. It is considered the primary cause of respiratory and cardiovascular diseases leading to premature death. The Global Burden of Disease, 2010, report estimated that ambient air pollution was responsible for approximately 3.2 million deaths globally and 0.627 million deaths in India (Sustainable Development Department, World Bank 2013a).

A recent research provides estimates of PM_{2.5} concentrations at district and urban agglomeration levels in India (Figure 3.1). It can be observed that the PM_{2.5} concentrations in North Indian districts are much higher than the prescribed ambient air quality standards. It estimates that approximately 660 million people in India are exposed to ambient-air particulate pollution. The study highlights the relation between PM_{2.5} emissions and life expectancy. It concludes that if ambient-air quality standards are achieved, life expectancy is anticipated to increase by 3.2 years per person (Greenstone et al. 2015).

Figure 3.1 Estimates of PM_{2.5} concentrations across India

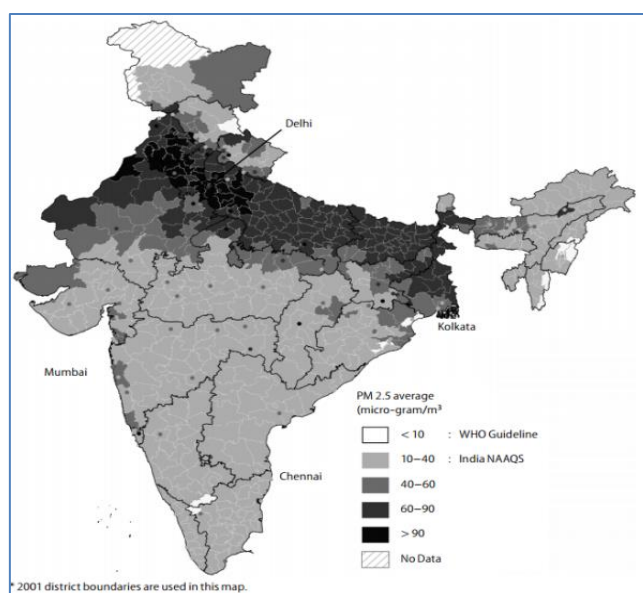

(Greenstone et al. 2015)

PM pollution standards as per the National Ambient Air Quality Standards and the World Health Organization (WHO) are given in Table 3.1 below. As illustrated, PM pollution standards in India are far higher than WHO-recommended levels.

Table 3.1 PM pollution standards in India

PM Pollution Standards		India NAAQS	WHO
		2009	2005
PM ₁₀	Annual average	60 µg/m ³	20 µg/m ³
	Daily average	100 µg/m ³	50 µg/m ³
PM _{2.5}	Annual average	40 µg/m ³	10 µg/m ³
	Daily average	60 µg/m ³	25 µg/m ³

(Greenstone et al. 2015)

A World Bank study estimated that the annual cost of environmental degradation is about INR 3.75 trillion, which is equivalent to 5.7% of India’s GDP. Outdoor air pollution accounts for about 30% of the total environmental degradation cost (Sustainable Development Department, World Bank 2013a). The annual environmental health costs per person due to indoor and outdoor air pollution are shown in Figure 3.2.

Figure 3.2 Annual environmental health losses per person of the exposed population

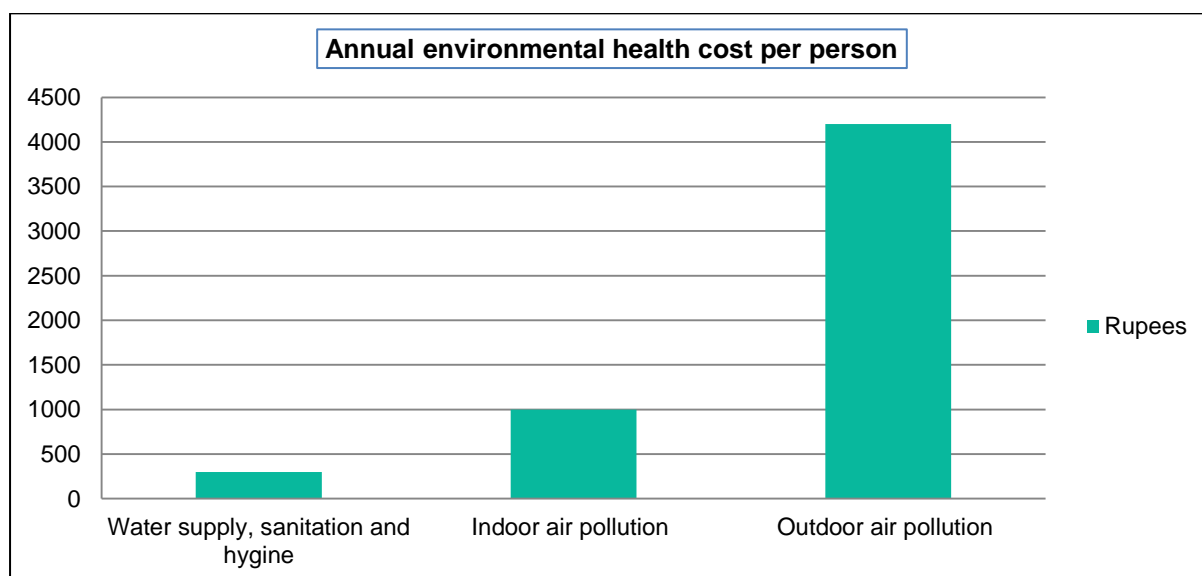

(Sustainable Development Department, World Bank 2013b)

Sulfur content in automotive fuels has a direct impact on the ambient-air quality and health. High-sulfur fuels lead to increased PM emissions in diesel-operated vehicles. In an attempt to mitigate the effects of high sulfur, low-sulfur fuel standards such as BS IV and BS V are recommended by the Auto Fuel Vision & Policy 2025 Committee (Government of India 2014). A shift from BS III to BS IV fuel standards would result in a corresponding reduction in sulfur content from 350 ppm to 50 ppm. A similar shift to BS V fuel standards would lead to a further reduction in sulfur content (10 ppm).

However, there is a cost constraint for adopting BS V fuel standards. A few news reports indicate that the estimated investment (cost for upgradation of fuel quality) ranges from INR 25,000 crores to INR 80,000 crores (Government of India 2014). In this context, the Auto Fuel Vision & Policy 2025 Committee recommended that a “High-Sulfur Cess” of 75 paise per liter on BS III automotive fuels be imposed. It also recommended a “Special

Fuel Upgradation Cess” of 75 paise per liter on automotive fuels. The total income from these taxes, which is estimated to be around INR 74,000 crores, will fund the expenses necessary for fuel quality upgradation.

This fuel upgradation constraint, along with the reduced PM_{2.5} reduction potential (BS IV to BS V fuel standards) sets the stage for India to leapfrog to EV adoption in the urban context.

Benefits from Electric Buses

Air-quality benefits from electric buses can be attributed to a reduction in local air pollution compared with conventional diesel and CNG buses. Electric buses contribute to zero tail-pipe emissions, which are a major source of air pollution in urban areas. The introduction of electric buses will be beneficial in urban areas, where local air pollution is a concern. Introduction of electric buses becomes favorable in regions where the grid has a major share from renewable energy. When the electric buses are charged using electricity generated by renewable energy, the benefits are way beyond the local air quality. Electric buses combined with renewable electricity will ensure the future reduction in fossil fuel demand and a way forward for cleaner technologies and fuels.

3.2 Noise

Noise pollution is linked to a number of health issues, including stroke, hypertension, dementia and coronary heart disease. In addition to these concerns are the less serious but more prevalent issues of annoyance and sleep disturbance. Further still, one can also consider the effects of excess noise pollution on economic productivity; it not only causes health problems, but also decreases economic efficiency.

Diesel vs. Electric Buses: Comparison of Noise Levels

Generally, electric buses are quieter than diesel buses by 17 decibels (dB). Diesel buses can produce noise that is as loud as 70 dB, whereas electric buses tend to operate at about 60 db. Since dB is on a logarithmic scale, this means that electric buses are half as loud as diesel buses. Such a significant reduction in noise “at the source” has the potential to have a significant impact on well-being.

It is important to note, however, that at high speeds, all types of buses generate roughly the same amount of noise, as the main source of noise is the tires on the pavement and not the engine. According to a study, the difference between the noise levels generated by diesel and electric buses is most significant at speeds up to 25 mph (40 kmph) (Rose and Staiano 2007) as shown in Figure 3.3. However, mobility indicators for buses in Indian urban driving conditions show that traffic rarely exceeds these speeds. Thus, the reduction in noise from electric buses will be quite tangible in the context of urban India.

Figure 3.3 Bus categories, travel speed and associated noise levels

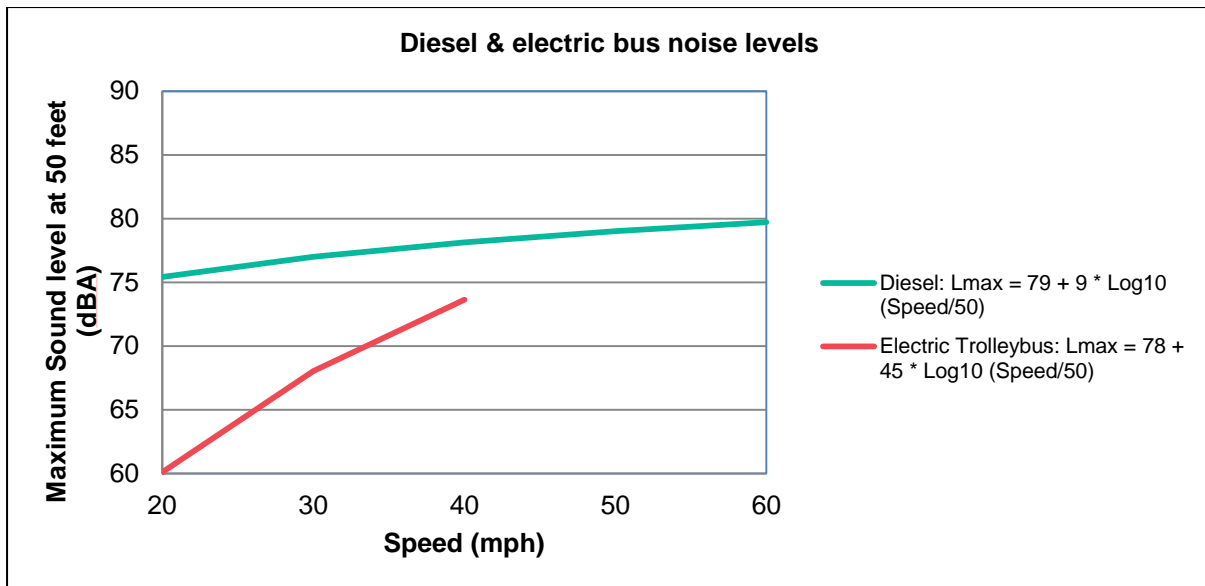

(Rose and Staiano 2007)

For those who live or work within earshot of a bus route, the benefits of replacing diesel buses with electric ones are a bit more complicated to determine. The same study estimates that the noise from a diesel bus travels three times as far as the noise from an electric bus. Thus, the switch to electric buses would reduce the noise-affected area by 66%. While further research is needed to determine the exact benefit afforded to those who live close enough to a bus route to still hear the noise from electric buses, one can at least be sure that their state of well-being will not decline.

Effects of Noise Level on Health

High noise levels can have direct impacts on human health, be it through sleep disturbance, hypertension or dementia.

A study by the WHO estimated that being severely sleep-deprived due to environmental noise reduces a healthy individual's well-being by about 7% (World Health Organization & European Centre for Environment and Health, 2004). The cost, in terms of sleep deprivation due to a single-dB increase in the sound level, can be significant. In addition, there is a well-documented relationship between noise disturbance and hypertension. While the causal mechanisms are not certain, one hypothesis is that prolonged exposure to noise causes the body to keep releasing stress hormones, which leads to an increase in blood pressure. A hypertensive individual faces a higher risk of suffering a stroke and dementia.

Table 3.2 shows the estimated cost of dB increase in average noise levels. While one cannot completely take this information at face value, since there are a number of factors that contribute to the overall noise level (e.g., airports, other vehicles, noisy neighbors), one can see that the costs of even a slight increase in noise level can be very high. However, once noise levels exceed 60 dB (noise generated by an electric bus at a moderate speed), the link to acute myocardial infarction (AMI), strokes, dementia and sleep disturbance begins. For example, a 1-dB increase from 67 to 68 dB is estimated to cost a household more than GBP 117 per year. Of this, GBP 14 is attributed to an increased risk of AMI, approximately GBP 3 to increased risk of stroke and GBP 55.94 is the estimated cost of sleep disturbance. These figures may be different in the Indian context, but they are quite significant, nonetheless (Department for Environment, Food & Rural Affairs - GOV.UK 2014).

Table 3.2 Effects of noise on health – monetary values

Road traffic noise marginal values in £ per household per dB change, 2014 prices						
Change in Noise Metric by Decibel (dB)	Health			Amenity		Total
	Direct AMI	Stroke	Dementia	Sleep Disturbance	Annoyance	
54.0...55.0	£0.00	£2.64	£3.99	£25.71	£15.45	£47.78
57.0 58.0	£0.00	£2.66	£4.01	£32.69	£19.13	£58.49
61.0 62.0	£5.67	£2.68	£4.05	£41.99	£25.82	£80.21
64.0 65.0	£9.86	£2.70	£4.07	£48.96	£32.17	£97.78
67.0 68.0	£14.41	£2.72	£4.10	£55.94	£39.67	£116.85
70.0 71.0	£19.32	£2.74	£4.13	£62.92	£48.31	£137.42
73.0 74.0	£24.58	£2.77	£4.15	£69.89	£58.10	£159.49

(Department for Environment, Food & Rural Affairs - GOV.UK 2014)

Effect on Productivity

The complete nature of the effects of noise exposure on productivity is not yet known, though there is enough evidence, both scientific and anecdotal, to be certain that it is significant.

For example, sleep disturbance, as discussed above, is unpleasant, which in itself can have an added cost in the workplace or classroom the next day. Studies have shown that noise exposure can negatively affect reading comprehension. Here the effects apply to not only those who work or go to school near a noisy bus route, but also to those whose cognitive performance is affected by noise exposure at home.

3.3 Energy Security

Crude Oil Prices in India

India has been an importer of crude oil, and the increasing and fluctuating crude oil prices have had a direct impact on the balance of the payment situation. As shown in Figure 3.4, the average crude oil price followed an increasing trend till 2011–2012. However, there was a significant reduction in prices in 2014–2015. For the period 2001–2015, the price of crude oil increased three times from USD 27 to USD 84 per barrel (Ministry of Petroleum & Natural Gas, Gol 2015). From these observations, it can be concluded that the price of crude oil has fluctuated widely from a 400% increase (2001–2012) to a 25% decrease (2011–2012 to 2013–2014).

Figure 3.4 Crude oil prices in India, 2001–2015

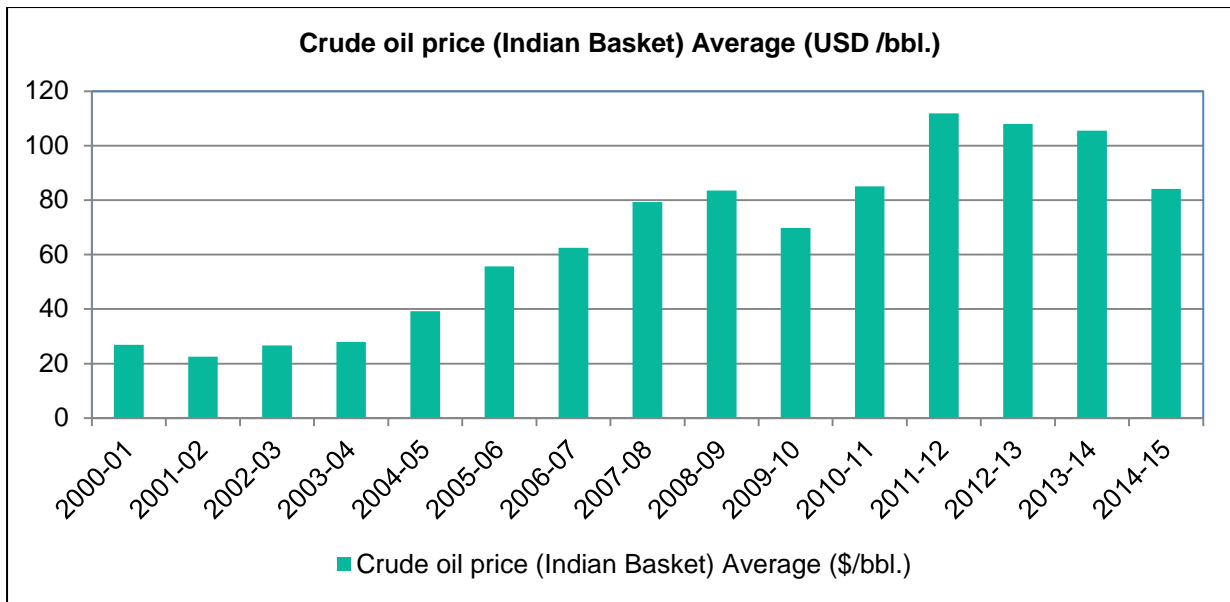

(Ministry of Petroleum & Natural Gas, GoI 2015)

As India is heavily dependent on crude oil imports for transport fuels on an average of 74% (Ministry of Petroleum & Natural Gas, GoI 2015), this price volatility poses a severe threat to India’s energy security (if this trend of wide fluctuations continues).

Figure 3.5 Domestic crude oil consumption vs. domestic crude oil production

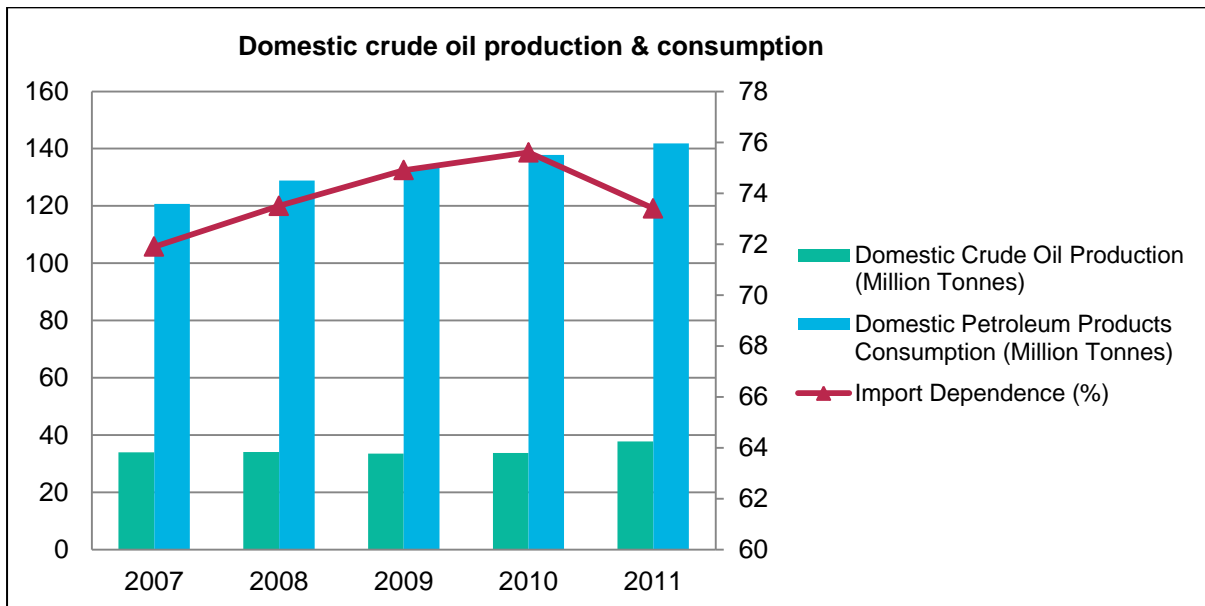

(Ernst and Young, n.d.)

India’s crude oil import bill during April–August 2014–2015 was approximately USD 67,805.81 million. Out of the total imports, crude oil imports constituted 35% of the total imports for the period April–August 2014–2015 as against a share of 25% for the period April–August 2015–2016 (Ministry of Commerce and Industry 2015). There is a 10% reduction in the total import bill for the consecutive years; however, there is no significant reduction in the trade deficit (1.2%). Based on the estimates of the Ministry of Commerce and Industry, there is a reduction of 39% in crude oil import for the periods 2014–2015 and 2015–2016.

3.4 Jobs

A growth in the EV sector will produce direct and indirect jobs. The development of certain sectors such as vehicle manufacturing, batteries, chargers and other EV-related accessories would result in direct job creation.

The potential for job creation can be gauged from the instance of EV manufacturing in China. Evidence from that country suggests that the manufacture of EVs can constitute 15% of the total automobile production. The Chinese government has an official program that aims to produce 1.67 million new EVs and create of 1.2 million jobs annually from 2010–2020 (Pan, MA, and Zhang 2011).

Indian Context

The Indian automobile industry is one of the fastest growing globally. Both volume and exports have been consistently rising over the past 10 years. According to the National Electric Mobility Mission Plan 2020 (NEMMP 2020), by 2020 the annual demand for passenger vehicles, commercial vehicles and two-wheelers in India will be 10 million, 2.7 million and 34 million units, respectively, making India the third largest vehicle market in the world. While the NEMMP aims to make India a global manufacturer of EVs, the domestic market for EVs appears to be promising.

While growth in the EV sector has at times resulted in a net loss of jobs in more developed countries, India is uniquely placed as it has one of the lowest levels of vehicle penetration in the world. For India, adoption of EVs would not be a transition from fuel-powered vehicles to EVs; instead, India has the potential to have consumers who will purchase an EV as their first vehicle.

4. Policy Landscape

4.1 National Electric Mobility Mission Plan (NEMMP) 2020

As India continues its rapid economic development, the demand for automobiles is expected to grow. These automobiles are set to increase CO₂ emissions and crude oil demand for the nation as a whole (elaborated in the section Transport Scenario Projections for India). NEMMP2020 is an initiative taken by the Department of Heavy Industries (DHI) that aims to accelerate the growth of the electric and hybrid components of the automotive sector. It focuses primarily on fast-tracking the manufacturing and introduction of EVs in India. The benefits of this Plan are numerous. Most notably, such an initiative has the potential to reduce CO₂ emissions and the dependence on crude oil. In addition, growth in this industry will make India a significant player in the global EV market.

The vision statement of the NEMMP states that the aim of the policy is to encourage reliable, affordable and efficient adoption of EV technology through government and industry collaboration. The Plan makes an assessment regarding the uptake of EVs in India. It proposes that about 6–7 million EVs can be sold in India by 2020 (Table 4.1).

Table 4.1 Potential adoption of EVs in India by 2020

Vehicle/Technology Segment	Potential for EVs (2020) (Million Units)
BEVs (battery-electric vehicles) (2 wheelers)	3.5–5
HEVs (hybrid-electric vehicles) (4 wheelers, bus, LCVs)	1.3–1.4
Other BEVs (3 wheelers, 4 wheelers, bus, LCVs)	0.2–0.4
Total	5–7

(Department of Heavy Industries, GoI 2012)

Implementation of Battery Electric Vehicles

Each vehicle segment has different levels of implementation difficulties and poses distinct challenges for the introduction of EVs. The ease of implementation of BEVs as assessed by the NEMMP states that the introduction of BEVs in the two-wheeler segment is the highest, followed by buses and the three-wheeler segment. According to NEMMP estimates, the future demand for BEVs will be about 3.7–5.4 million units.

Barriers to adoption of BEVs

The NEMMP identifies the following potential barriers to the adoption of BEVs:

- High acquisition costs
- Challenges related to batteries (related to price, range, performance, etc.)
- Consumer acceptability (low consumer awareness, current price, performance gap, etc.)
- Technology development (low level of R&D in this area, limited current capabilities)
- Manufacturing investments (limited domestic manufacturing capabilities, non-existent supply chain)
- Performance standards of BEVs in comparison with traditional ICE-based vehicles (range, speed, acceleration, etc.)
- Lack of charging infrastructure.

Policy Tools

The NEMMP identifies critical areas where interventions would be required. These include the following:

Demand incentives: The Plan estimates that for BEVs the investment requirement would be about INR 13,500–INR 13,850 crores, whereas for buses that investment would be about INR 500–INR 550 crores.

- **Supply-side incentives:** The Plan draws up a four-phase approach for building India’s EV manufacturing capabilities. These include initially developing R&D capacities, strengthening domestic capabilities and initiating localization. The latter phases focus on creating high capabilities across the value chain, developing indigenized products, sourcing components locally, creating an EV component ecosystem, targeting the export market, and investments to enhance capabilities and production plan for exports.
- **Power and charging infrastructure:** It is estimated that by 2020, 2–4 MW of extra power generation capacity and an investment of INR 10–INR 20 crores may be required to build 300–400 charging terminals for buses and for building the overall EV charging infrastructure. Owing to their capacity and lifespan, LIBs are the preferred choice for EVs. However, these batteries have a high cost. Factors such as technology innovation and scale of production can impact almost 90% of the LIB cost. In the case of technology, identifying cheaper raw materials and safe chemistries could reduce the cost of batteries.
- Other critical factors that have been identified include imposition of stringent fuel efficiency norms and R&D incentives.

4.2 Faster Adoption and Manufacturing of Electric Vehicles (FAME)

The FAME scheme is intended to provide financial incentives to support the NEMMP, which promotes the development and uptake of EVs in India. Phase-1 of the scheme will be implemented over a 2-year period, i.e., FY 2015–2016 and FY 2016–2017, commencing from April 1, 2015. An overall allocation of INR 795 crores will primarily be used for implementing demand incentives.

Coverage

The cities covered under FAME include those covered under the “Smart Cities” initiatives, major metro agglomerations (Delhi NCR, Greater Mumbai, Kolkata, Chennai, Bengaluru, Hyderabad and Ahmedabad), all cities with populations greater than 1 million and cities of the North-Eastern states. The scheme will target all vehicle sizes and types (from hybrid to fully electric).

Demand Incentives

Previous incentives came in the form of assistance for vehicle purchase and reductions in taxes, and they were sometimes provided by the state government. In the FAME India Scheme, the demand incentive will be disbursed through an e-enabled framework and mechanism set up under the DHI. The scheme envisages the setting up of adequate public charging infrastructure to install confidence among EV users, through active participation and involvement of various stakeholders including government and non-government agencies. Interlinking of renewable energy sources with charging infrastructure, smart grid, use of Information and Communication technology, etc., will be encouraged. Demand incentives will be based on a combination of vehicle size, fuel efficiency and battery type. Details of demand incentives are provided in Table 4.2.

Table 4.2 EVs – incentives in INR

Vehicle Segment	Minimum Incentive (INR)	Maximum Incentive (INR)
Two-wheeler, scooter	1,800	22,000
Motorcycle	3,500	29,000
Three-wheeler	3,300	61,000
Four-wheeler, cars	11,000	1,38,000
LCVs	17,000	1,87,000
Bus	30,00,000	66,00,000
Retro Fitment Category	15% or 30,000 if reduction in fuel consumption is 10%–30%	30% of Kit price or 90,000 if reduction in fuel consumption is more than 30%

(Department of Heavy Industries, GoI 2015)

4.3 National Green Tribunal (NGT)

The National Green Tribunal (NGT) was established as a specialized body to address challenges related to environmental protection, and conservation of forests and natural resources from a multidisciplinary approach. It has the power to intervene on substantial questions related to environment and is also responsible for the enforcement of legal rights. It comprises experts from legal, scientific and technical backgrounds, and considers principles of sustainable development, precautionary principle and polluter pays principle in decision-making. The tribunal has the powers of a civil court in executing a decision. It deals with issues related to environment, and disputes arising from questions related to environmental and pollution laws.

The NGT interventions with respect to vehicle air pollution cases, including restriction of old vehicles and restriction on the number of vehicles. In the eco-sensitive area of Rohtang Pass, Himachal Pradesh, in an attempt to reduce the impact of air pollution, the NGT has ordered the banning of diesel vehicles and has also restricted the number of vehicles to 1,000 per day for a period of 3 months. It has also ordered an environment tax of INR 1,000 for petrol vehicles and INR 2,500 for diesel vehicles entering the tourist area. As a pollution mitigation measure, the Tribunal suggested the state government to explore CNG vehicles. In NCR, Delhi, the NGT ordered heavy diesel vehicles more than 10 years old off the road. In an attempt to mitigate air pollution, the Tribunal also ordered the regional transport authorities to not register diesel vehicles that were older than 10 years old and petrol vehicles older than 15 years old.

4.4 Bureau of Energy Efficiency (BEE)/Star Ratings

The Bureau of Energy Efficiency (BEE) under the Ministry of Power has been the nodal agency known for the implementation of the energy labeling program for most consumer durables in India. The program since initiation in 2006 has invoked 19 equipment/appliances in the residential, industrial, commercial and agricultural sectors. The labeling programs are intended to reduce the energy consumption of appliances without diminishing the services they provide to consumers. It is also ensured, periodically, that standards are made more stringent where least-efficient products are removed from the market and more efficient products are introduced.

In early 2014, the BEE notified fuel economy standards, i.e., Corporate Average Fuel Consumption Standards (CAFC), for passenger cars (Ministry of Power, GoI 2015). The nature of the design was based on

kilometers/liter and cohered with the US CAFE Standards. The BEE has plans to implement this in a phase-wise manner. The scheme would direct all car manufacturers to attain a fleet average of 54.5 miles per gallon (23 km/L) by 2025 progressively (Gordon-Bloomfield 2015).

However, currently, convergence with existing process preferences are toward fuel quality and emission upgrades. The provision of testing will be consequently introduced for enforcement purposes. In order to accelerate the reduction in the average fuel consumption of new cars introduced in the Indian market, a two-pronged approach is proposed by the BEE:

1. New cars in the market would have medium- and long-term fuel consumption standards, providing regulatory indicators for manufacturers to continuously reduce the average fuel consumption of cars sold in the next 10-year period.
2. All new cars sold in the market would have a fuel efficiency label providing consumers with information on the fuel consumption of a car model, and of the relative fuel consumption of the model compared with that of other models in the same weight class.

With the broad two approaches, it is anticipated to develop a market for low-fuel-consumption models and at the same time envisage a market transformation in the automobile market toward highly efficient car models by decreasing fuel consumption levels

4.5 National Auto Fuel Policy, 2003, Auto Fuel Vision & Policy, 2025

The National Auto Fuel Policy 2003 specifies the fuel standards to be implemented in the country. Currently, the fuel standards implemented adhere to BS III standards and there has been talk of implementing BS V fuel standards. A move from BS III to BS V would lead to a reduction in sulfur content and PM_{2.5} emissions.

The sulfur content in automotive fuels has a direct impact on the ambient-air quality and health. India's shift toward low sulfur for its automotive fuels has resulted in the reduction of sulfur content from 2,000 ppm in 1999 to 150 ppm in 2010. The implementation of BS V standards in India will further lower the sulfur content to 10 ppm. In 2005, BS III fuel was mandated in 13 cities, with the rest of India having access to BS II fuel. Similarly in 2010, BS IV fuel was made available in 13 cities, whereas the rest of India used BS III fuel. The Ministry of Petroleum and Natural Gas aims to implement BS IV fuel in 50 additional cities by 2015. In major cities, with the implementation of BS IV standards, the sulfur content of diesel has reduced from 350 ppm to 50 ppm and petrol from 150 ppm to 50 ppm. The Auto Fuel Vision & Policy 2025 Committee has recommended an increase in the penetration of BS IV fuel standards from 2015 onwards and 100% coverage by 2017 (Government of India 2014).

The constraint for adopting low-sulfur fuel is the cost of fuel quality upgradation to produce BS V fuel (10 ppm sulfur). In this context, the Auto Fuel Vision & Policy 2025 committee recommended imposing a "High-Sulfur Cess" of 75 paise per liter on BS III automotive fuels. It also recommended a "Special Fuel Up-gradation Cess" of 75 paise per liter on automotive fuels. A total cess to a tune of INR 74,000 crores was proposed to fund the cost estimates required for fuel quality upgradation.

4.6 National Urban Transport Policy (NUTP)/Jawaharlal Nehru National Urban Renewal Mission (JNNURM)

The National Urban Transport Policy (NUTP) and the Jawaharlal Nehru National Urban Renewal Mission (JNNURM), which can be considered as precursors to the Atal Mission for Rejuvenation and Urban Transformation (AMRUT) and Faster Adoption & Manufacturing of Electric Vehicles (FAME) schemes, set the trend for sustainable urban transport planning in India. The NUTP encouraged greater use of public transport and non-motorized transport. It also called for the establishment of quality-focused integrated multimodal public transport systems in urban areas. The fiscal incentives from the central government through the JNNURM focused on the provision of inventory in terms of buses to urban areas to meet the public transport demand. Although the JNNURM provided funding for fleet augmentation, it did not provide for operating

costs, something that FAME/AMRUT might want to incorporate. Similarly, any initiative regarding urban transport must address issues of sustainability (e.g., the ASI framework). This would require a sustained policy intervention toward promoting public transport projects – and, specifically, non-polluting technologies such as pure EV technology.

4.7 Atal Mission for Rejuvenation and Urban Transformation (AMRUT)/ National Heritage City Development and Augmentation Yojana (HRIDAY)/Smart City Mission (SCM)

Atal Mission for Rejuvenation and Urban Transformation – AMRUT

Yet another policy that can be a finance vehicle in the transition toward public transport through adoption of EVs is the AMRUT scheme. Under this scheme, the central government proposes to spend INR 1 lakh crores during its tenure (2014–2019). Projects selected under the scheme would have special focus on urban infrastructure development.

AMRUT adopts a project approach to ensure basic infrastructure services related to water supply, sewerage, transport and development parks, to name a few sectors under the initiative. The mission will be implemented in 500 cities and towns each with a population of 1 lakh and above. Under this mission, states get the flexibility of designing schemes based on the needs of identified cities, and in their execution and monitoring. States will only submit the State Annual Action Plans to the center for a broad concurrence, based on which funds will be released.

Special-Purpose Vehicles (SPVs) will be created for each selected city and the respective states will be responsible to ensure that adequate resources are made available to the SPVs. The center will extend funding to the extent of 50% for cities with a population of up to 10 lakhs and a third of the project cost for cities with a population of above 10 lakhs. Given the fact that each city and town is unique, and has its own priorities for development, the center proposes an “area-based” approach to development that will cover retrofitting or redeveloping as per the local plan. Therefore, all state planning committees could plan projects on a need basis across the transportation, sanitation, housing and other sectors.

Like its predecessor – the National Urban Renewal Mission – which financed the purchase of buses by city transport corporations, which led to a rejuvenation of public transport in Indian cities – AMRUT presents itself as an ideal platform for city bus transport corporations to leapfrog technologies and contribute positively toward air quality, energy security and job creation through the adoption of EV technology.

National Heritage City Development and Augmentation Yojana – HRIDAY

Yet another scheme that has been launched in tandem with the initiatives mentioned above is HRIDAY. The duration of the HRIDAY scheme would be 4 years starting December 2014. The objective of this scheme is to preserve the rich and diverse natural heritage areas. This scheme will be implemented by the center with 100% funding by the central government. Cities will be required to prepare a Heritage Management Plan for identified projects for availing assistance under this scheme.

These schemes present a different approach to bringing about holistic development of states and have a component of timely project reviews by the center, which will ensure that projects are implemented efficiently.

Smart City Mission (SCM)

The intention of building smart cities in India has been pursued by previous governments at the center and the states, although through seemingly disjointed initiatives such as smart townships along the Delhi–Mumbai Industrial Corridor and the GIFT city in Gujarat. In early 2014, a budgetary allocation of INR 7,060 crores for the development of “100 Smart Cities” in India was introduced. Over the past one year, various city governments signed a Memorandum of Understanding with various external and foreign agencies to secure both technical and financial assistance in making their cities smart.

The Smart Cities Mission Statement and Guidelines released by the Ministry of Urban Development (MoUD) identifies 10 core infrastructure elements, where “sustainable development” and “public transport” are also listed²³. Thus, adoption and deployment of EVs can become a significant strategy in potential smart cities.

The guidelines also seek to ensure convergence between SCM, AMRUT and HRIDAY. Adhering to a common reference framework becomes particularly significant in drawing this convergence, which has remained one of the major challenges in attaining India’s urban goals. For example, the goals of AMRUT and SCM cannot be treated as mutually exclusive and the habitations under AMRUT shall need as much “smart solutions” as cities under the SCM.

²³ Ten core infrastructure elements are: (i)adequate water supply, (ii)assured electricity supply, (iii)sanitation, including solid-waste management, (iv)efficient urban mobility and public transport, (v)affordable housing, especially for poor, (vi)robust IT connectivity and digitization, (vii)good governance, especially e-governance and citizen participation, (viii)sustainable development, (ix)safety, security of citizens, particularly women, children and elderly, and (ix)health and education.

5. Electric Vehicles – Technology Trends and Challenges

While Chapter 2 describes the concepts related to EV technologies, this chapter discusses technology trends and challenges. The first section of this chapter discusses the costs of BE buses and the effect of Depth of Discharge (DoD) on the cost of the battery. Further, the chapter demonstrates how an increase in the number of charging stations [Electric Vehicle Supply Equipment (EVSE)] can facilitate EV adoption, innovations in smart grid technology, vehicle-to-grid systems (V2G), etc., and their impact on the charging infrastructure. The final section of the chapter analyzes the current challenges related to the EV sector.

5.1. Hype Cycle Analysis for Electric Vehicles Technology

Gartner’s Hype Cycle provides insights into how technology progresses with time. It can help in making strategic business decisions to improve the market penetration of the concerned technology. According to the Gartner Hype Cycle theory, a new invention or new technology goes through five phases of a technology life cycle: technology trigger, peak of inflated expectations, trough of disillusionment, slope of enlightenment and plateau of productivity (Gartner Inc. 2015). According to Urban Foresight’s report, the EV technology is also going through a similar Gartner hype cycle (Urban Foresight et al. 2014).

Figure 5.1 Gartner’s hype cycle for EV technology

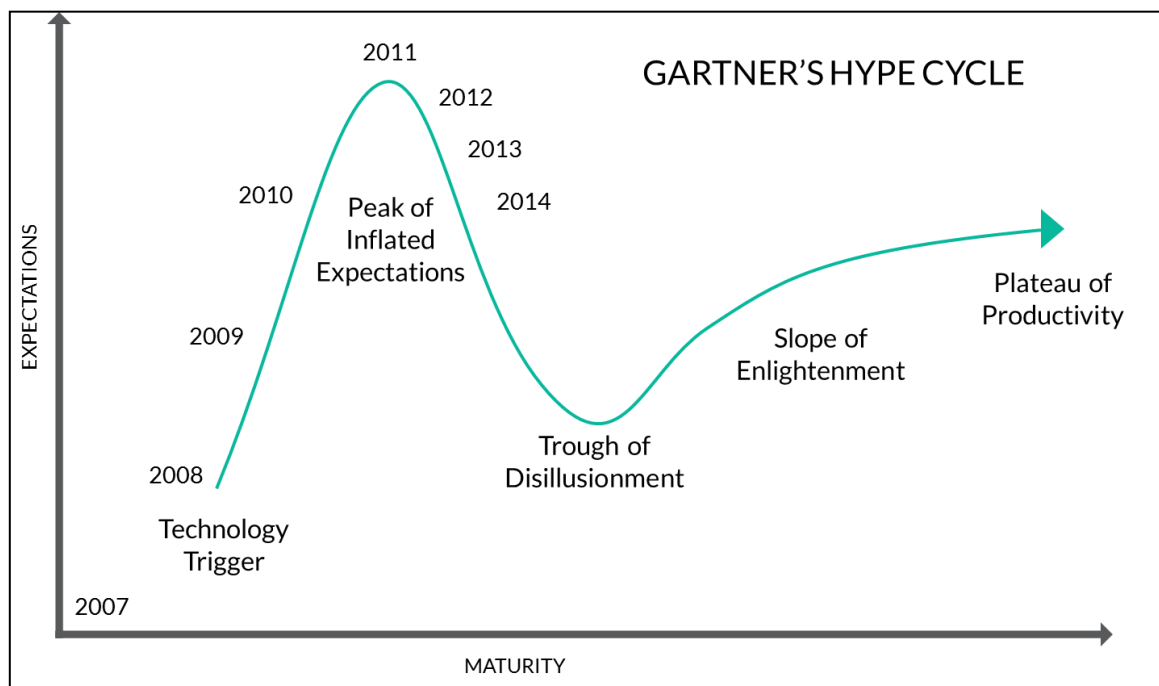

(Urban Foresight et al. 2014)

In Figure 5.1, technology maturity, which is time-dependent, is shown on the abscissa, whereas the expectation levels from the society and the industry are shown on the other coordinate of the graph. As can be seen in Figure 5.1, the EV technology went through this “technology trigger” phase in 2008. The trigger was economic recession, which sparked the need to revamp the vehicle industry. EVs were seen as a promising option to bolster the vehicle industry. Many deployments and demonstrations of EV technology were spurred through government and private partnerships. This caused the expectation that EV technology maturity would be reached by 2011. A readjustment in the expectation level was seen after 2011, because EV technology is

not yet mature due to challenges in battery technology. The expectation has continued to reduce and it will reach the Trough of Disillusionment phase. However, the expectation and maturity of the EV technology will stabilize and mass adoption of EVs is anticipated in the coming years (Urban Foresight et al. 2014). Keeping this in mind, the next section focuses on global deployments of hybrid and BE buses.

5.2. Hybrid Bus Deployment

Presently, hybrid buses have seen wider deployments as compared with BE buses. Since BE buses require a huge battery pack, the hybrid bus segment has taken precedence in initial deployments. Three case studies of hybrid buses have been chosen. The first case study is related to London, UK, where more than 1,300 hybrid buses are running in the passenger segment (Greater London Authority 2015). The second case is that of New York, USA, where city transit has more than 1,600 vehicles in their fleet (Young 2015). The third case study is related to HEV deployment in China.

United Kingdom

In London, more than 1,300 hybrid buses are in operation in the passenger segment (Greater London Authority 2015). The first hybrid bus was introduced in March 2006, and by July 2012, more than 300 hybrid buses were operating in London. The first electric bus fleet had six single-deck hybrid buses, which were manufactured by Wright Electrocitiy. These buses were launched in early 2006. The first electric double-deck bus was introduced in October 2006. This bus was manufactured by Wrightbus and started operations in February 2007. The authority for transport for Greater London, Transport for London (TfL), has planned to have total of 1,700 hybrid buses in operation by 2016. This will constitute about 20% of the total bus fleet. This deployment is projected to reduce NO_x emissions in the city by 88%. Moreover, they have projected a decrease of CO₂ emissions of 27,500 tons per year. The single-deck electric bus models, which are in operations under "Transport for London", are Alexander Dennis Enviro200H, Wright Electrocitiy, Optare Tempo and BYD electric, and the double-deck buses are Volvo B5LH, Wright Gemini 2, Alexander Dennis Enviro400H, Volvo B5L Hybrid and New Routemaster. This deployment of hybrid buses in London is considered a big success.

United States of America

New York City Transit (NYCT) is the biggest public transit company in the United States. They have deployed more than 1,600 hybrid buses. In the first phase, NYCT ordered a fleet of 10 hybrid buses in 1998 – Orion VI diesel hybrid electric buses (U.S. Department of Energy 2001). In the same plan, 125 more buses were ordered, which have been in operation since 2002. In the evaluation report of the first plan (in 2006), the fuel economy of hybrid buses was reported to be 26%–52% higher than that of diesel buses from the NYCT fleet. Additionally, the maintenance costs for the hybrid buses were reported to be less as compared with those of the diesel buses (U.S. Department of Energy, n.d.). After the evaluation, the NYCT announced an additional order of 500 "Orion/BAE Systems" next-generation (Gen II) hybrid buses at a cost of USD 385,000 each (Barnitt and Chandler 2006). In the next evaluation report by the National Renewable Energy Laboratory (NREL) in 2008, the additional 200 buses were evaluated. According to the report, the new buses (Gen II) were more expensive than the old hybrid buses (Gen I) due to addition of an Exhaust Gas Recirculation (EGR) system with the engine. Moreover, the fuel economy of the new buses was also less because of the EGR systems. However, Gen II buses had zero battery failures as compared with Gen I buses, which had 3%–4% battery failures per year. The Gen II fleet also reduced NO_x pollutions from 4 g/bhp-h to 2.5 g/bhp-h (Barnitt 2008). Although hybrid buses had many benefits in terms of reduced pollution and operating costs, the NYCT has decided to replace the existing hybrid buses in the fleet with diesel-engine buses. The main reason is that the warranties on the old hybrid engines are about to expire shortly and the NYCT has to bear the added cost of maintaining the hybrid systems. Therefore, 15 years after the first hybrid bus was run, in July 2013, the NYCT decided to gradually take out the hybrid buses from the fleet. In the first withdrawal plan, the number of hybrids buses will be cut down to 1,288 from the current fleet size of 1,677 by 2016 (Young 2015).

China

Rapid urbanization and the resulting increase in demand for public transport systems seem to have made China the largest market for passenger buses in the world. The country sold 3,374 units of electric buses by 2011 and is anticipated to reach more than 12,000 units, making the share of electric buses more than 14% by 2018. According to the “Strategic Analysis of the Chinese Hybrid and Electric Transit Bus Market” report, total bus sales will be more than 80,000 by 2018 and it will further strengthen China’s domination in the global transportation market (PR Newswire 2012). According to “China Bus Industry Report, 2015–2018”, hybrid buses are no longer part of the national subsidy scheme. Therefore, hybrid buses lost the sales and market share in 2014. Hybrid buses constituted only 5.5% of the total new-energy (non-diesel) bus sales and BE buses had the biggest share of 47.5% in the same segment in 2014. The rise in the market share of BE buses is attributed to technology maturity and enabling policies (Business wire 2015).

5.3. Battery Electric Bus Deployment

In order to reduce local emission and noise pollution, governments are providing more incentives to BE buses. China has demonstrated major deployments in the BE bus segment. In many other countries, the number of BE buses deployed per city is usually less than 10 vehicles. Build Your Dreams (BYD) Auto, Proterra, Optare and Alexander Dennis Limited (ADL) are some of the few companies that manufacture BE buses. Since the emergence of BYD, BE buses are being deployed rapidly in various cities across the world.

Build Your Dreams (BYD) Auto

In April 2015, the Chinese company BYD Auto announced that they had delivered more than 3,400 BE buses since the launch of their first BE bus in May 2010. A significant number of those buses are operational in the Chinese cities of Shenzhen, Nanjing, Hangzhou and Dalian, as public transport buses. BYD has also deployed their BE buses in 100 cities across the world, including Los Angeles, Stanford University, London, Amsterdam and Tokyo (Chen 2015). BYD has a current production capacity of more than 1,000 buses per year (Business wire 2014). This number is considerably large for a new technology like BEV. The remainder of the BE bus makers are managing to sell only about 100 units every year (Loveday 2015). These numbers suggest that BYD is the market leader and has virtually no competition in this segment.

According to BYD estimates, at the most optimum running conditions, every BYD BE bus has the ability to save 2.77 trees every day (PV magazine 2014).

BYD in China

In August 2011, BYD delivered 200 BE buses to the Shenzhen Public Transit system for a university event. These buses are now operating in the city’s public transportation fleet. By the year 2012, BYD BE buses were operating in another four Chinese cities, which included 200 buses in Shenzhen, 100 buses in Changsha, 5 buses in Shaoguan and 50 buses in Xi’an. Shenzhen had the world’s largest BE bus fleet of BYD K9 and the fleet had operated over 9,216,000 km by the end of August 2012 (BYD Auto 2015). The Chinese metropolis of Dalian currently has the biggest fleet of 600 BE buses (from BYD), which is expected to reach 1,200 by the end of 2015 (Business wire 2014).

BYD in Israel

The Dan Bus Company, in Tel Aviv, is the local public transport company for the city. They have taken up BE bus deployment to reduce emissions and noise in the city, and have signed a contract with BYD to purchase 700 full-size BE buses. The first batch of these buses was deployed at the end of 2012. Dan Bus Company has planned to replace about half of its current fleet, which is about 1,300 buses, with the BE bus models (Shamah 2012).

BYD in the United States of America

The Los Angeles County Metropolitan Transportation Authority (Metro) has announced a USD 30 million deal with BYD for 25 BE buses. According to the contract, BYD needs to generate local jobs through the BE-bus-manufacturing sector. Therefore, BYD has agreed to do the final assembly of buses in their new plant in Lancaster, California. The company expects to produce 50 buses a year by 2015 and 1,000 buses annually in Lancaster over the next two decades. BYD has manufactured the 60-foot Lancaster eBus, the largest BE bus in the world, capable of carrying 120 passengers. These buses are powered by BYD's lithium iron-phosphate batteries. These batteries will also be manufactured locally in the United States of America (He 2013).

Proterra – BE bus company

Proterra is yet another leading BE bus manufacturer. Proterra has provided over 100 BE buses to 14 transit companies across North America. It constitutes about 70% of USA's BE bus market. In 2014, Proterra announced a national expansion plan to double the production of BE buses. In August 2015, Proterra had 433 units on order, which includes current confirmed orders of 110 BE bus units along with 323 future orders under contract (Proterra 2015).

In 2009, California came up with a mandate that said that the new bus fleet must have at least 15% zero-emission vehicles, i.e., BE buses. Afterwards, Proterra started the "California Clean Bus Tour" using their BE bus model, B35, in San Jose. This bus has a battery system from "TerraVolt Energy Storage System" that can be charged in 10 min. Also, regenerative braking could capture 90% of the bus's kinetic energy. Therefore, charging using grid electricity and energy conservation during regenerative braking gave the bus a driving range of 30–40 miles. The capital cost of the bus was very high as compared with that of a diesel bus. However, the high overall cost of a BE bus breaks even with respect to that of a diesel bus in 12 years (payback period) due to the low operating and maintenance costs (Yoney 2009). Their current bus model "Proterra Catalyst" has a seating capacity of 40. It has a fuel economy of 1.76kWh/mile, with top speed of 65 mph. It has been demonstrated that the bus can travel at over 1,100 km in 24 h. This is a major boost for customers who need these buses for long-range transportation.

ADL and BYD partnership

In July 2015, TfL (the public transport of London) ordered 51 BE buses to operate on two bus routes. These buses will be procured jointly from BYD and ADL. This contract is worth USD 30 million, including a full on-site repair and maintenance program for the term of the contract. This is the largest single order for BE buses in Europe (Kane 2015). Delivery is anticipated by August 2016. This is the first time BYD and ADL will be technology partners (PR Newswire 2015).

Other deployments

The Seoul Metropolitan Government (SMG) in South Korea deployed 14 BE buses in 2011. These buses are known as "peanut buses" due to their shape. This bus is manufactured with the help of Hyundai Heavy Industries and HankukFiber. The SMG has also planned to increase the number of BE buses in Gangnam and Yeouido to 377 by 2014–2015. These are mostly for shorter range travels of about 20 km. They also have ambitious plans of operating 1,20,000 electric cars and taxis, and install 1,10,000 battery-charging stations by 2020 (Kim 2011).

Several European cities such as Vienna, Amsterdam and Bremen have deployed BE buses. Vienna has introduced a fleet of 12 BE minibuses. These buses have a traveling range of 150 km, top speed of 62 kmph and a carrying capacity of 30 passengers. In July 2014, Amsterdam's Schiphol airport deployed 35 BE buses. This is the largest BE bus fleet currently in operation in Europe. In 2013, Bremen's public transport company, BSAG, started the testing of an 8m BE bus manufactured by Siemens-Rampini (Evans et al. 2014).

5.4. Costs of BE Buses

Despite several benefits of BE buses such as environmental friendliness and low fuel expenses compared with diesel buses, the high initial cost of BE buses has emerged as one of the major barriers in their mass adoption. For example, BE bus models such as BYD e6, Cobus 2500EL, and the 'Proterra Catalyst' bus cost approximately USD 300,000–USD 500,000, USD 560,000, and USD 700,000–USD 800,000, respectively (Evans et al. 2014)(Leung and Yan 2010)(Chernova 2015). On the other hand, the price of a Gen II hybrid bus in the NYCT fleet was USD 385,000 and the price of a diesel bus about USD 300,000 (Barnitt 2008). Currently, similar buses are priced between USD 400,000 and USD 500,000. The main reason for the higher cost of BE buses is the battery, which is a major cost component of these buses. In the case of BE buses, the size of the battery pack depends on the drive range of the vehicle, and the battery size influences the cost of the battery. Also, the big battery size (weight and volume) complicates the body and chassis design of BE buses. Therefore, BE buses are considerably more expensive as compared with their diesel bus counterparts.

Currently, LIBs are widely used as battery systems for BE bus application. Figure 5.2 shows the evolution of battery prices and the expected time to reach the benchmark price of USD 150/kWh. According to the figure, the price of LIBs has decreased from USD 1,000 per kWh to USD 410 per kWh for the period 2007–2014, i.e., prices are dropping at an average annual rate of 14% (Nykvist and Nilsson 2015). The study has also predicted that the prices will continue to decrease in the future at 6%–9% per year.

According to another study, the benchmark price of USD 230/kWh of LIBs will be attained in the next 5–7 years. At this price, the power from solar–battery hybrid generators will be cheaper than power generated conventionally (coal-based). This event will improve the pace of battery research and applications, resulting in a reduction in battery price of up to USD 150/kWh (Parkinson 2014a). A report by UBS, which is based on consultations with Navigant Research, estimates that the USD 230/kWh mark will be reached in the next 2–3 years. This decline has potential to further reduce battery prices to USD 100/kWh in due course (Parkinson 2014b). This decrement can be attributed to the technological advancement in battery materials and a well-established supply chain for the raw materials of the battery.

Figure 5.2 Trend of LIB prices and future price predictions till 2030

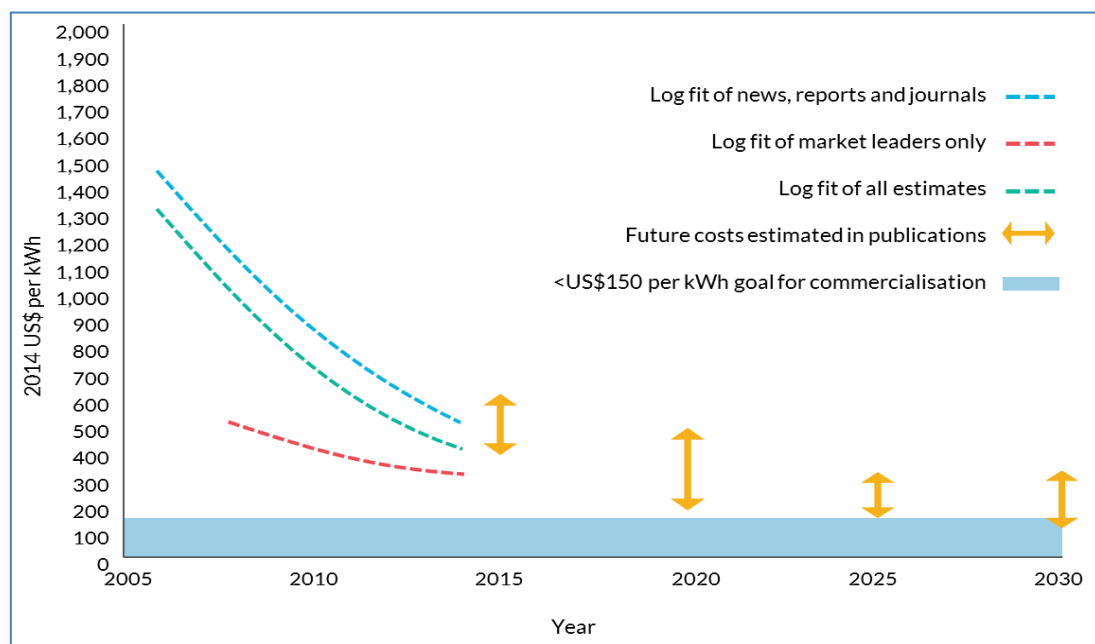

(Nykvist and Nilsson 2015)

Battery replacement cost is the second most important financial parameter after the capital cost of a bus in determining the TCO. The service life of a battery is much lesser than that of a BE bus. Therefore, the battery needs to be replaced at least once or twice in the entire operating life of the bus depending upon the operating conditions. Battery life depends on parameters like distance traveled per day, annual distance traveled, DoD of the battery, operating temperature, charging level, charging rate, etc. For example, DoD determines how deeply the battery is discharged during the discharging cycle. If a battery is allowed to deliver 25% energy in each discharge cycle, the battery will have a DoD of 25%; the battery still retains 75% of the initially stored energy at the end of each cycle.

Figure 5.3 shows the different DoDs for a lead-acid battery and their impact on its cycle life. According to Figure 5.3, a battery has a cycle life of about 350 cycles at 100% DoD, 600 cycles at 75% DoD and about 1,500 cycles at 30% DoD (Nykvist and Nilsson 2015). Evidently, the life of a battery is not linearly proportional to DoD values.

Figure 5.3 Cycle life of a lead-acid battery at different Depths-of-Discharge (DoDs)

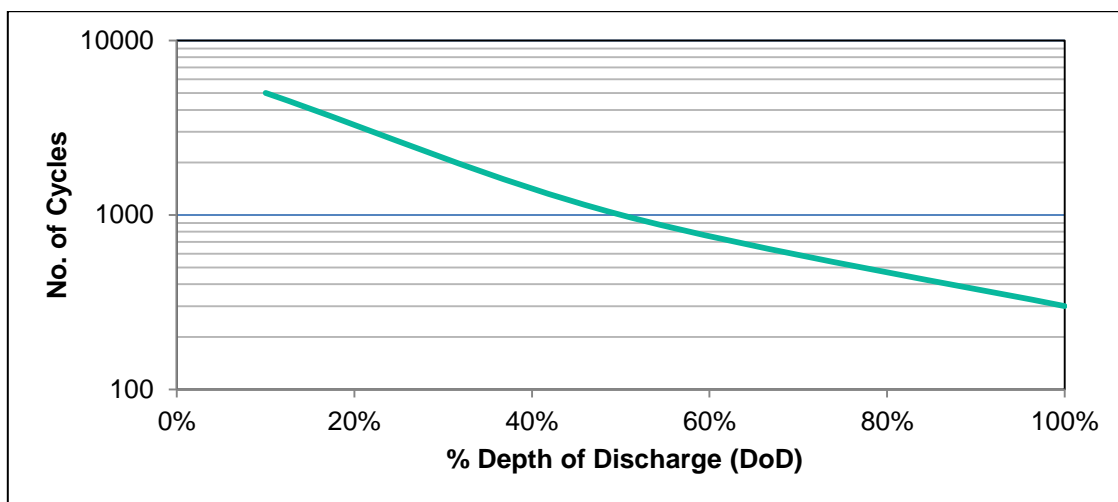

(CSTEP research)

Table 5.1 shows the relationship between DoD and the cost of a lead-acid battery. If DoD decreases from 100% to 50% in each cycle, the size and weight of the battery would need to be doubled to get the same energy capacity. However, this will increase the battery's life three times. Similarly, at 25% DoD, the life of the battery will be 5–6 times the original life, but the battery size requirement will increase four-fold. If a battery is discharged to 10% DoD, a 10 times bigger battery, which would achieve 10 times more cycle life, will be required.

Table 5.1 Trade-off between DoD and the life of the battery

Depth of Discharge	Battery Size (for Same Range)	Cycle Life	Battery Life	Battery Cost, Weight and Volume Multiple
100%	1 unit	300–500	1 year	1x
50%	2 units	1,200–1,500	3–4 year	2x
25%	4 units	2,000–2,500	5–6 year	4x
10%	10 units	3,750–4,700	10 year	10x

(Battery University 2015b)(CSTEP research)

Figure 5.4 shows change in cycle life as a function of DoD for an LIB at 25°C (Saft 2014). It shows that the cycle life of an LIB decreases with increasing DoD at a given temperature, charging level and charging rate. Analysis suggests that the cycle life *directly* translates to cost savings in the form of battery replacement costs. However, a lower DoD increases costs due to higher initial battery costs and lower energy efficiency (km/kWh)

due to additional weight. Moreover, the gain in cycle life of a battery follows a diminishing-returns pattern with respect to DoD. Hence, the optimum battery size and DoD should be determined with respect to drive cycle parameters to get the lowest TCO.

Figure 5.4 Cycle life of a typical LIB as a function of DoD at 25°C

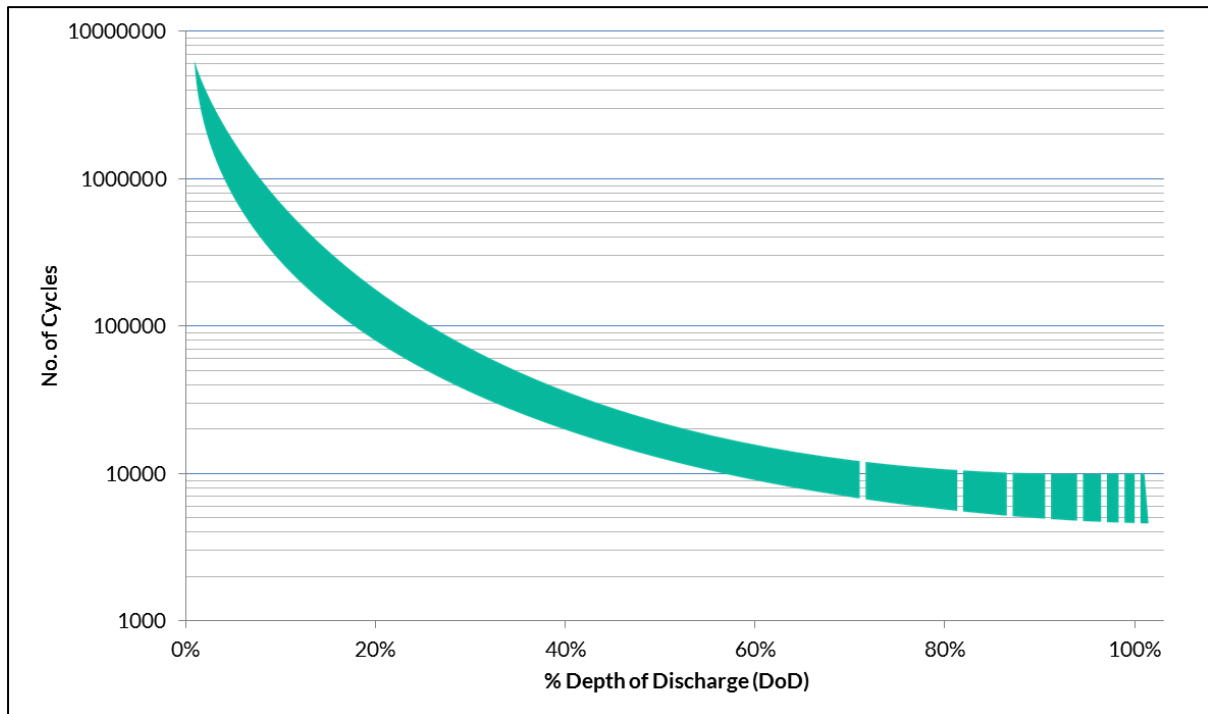

(Saft 2014)

In the Indian case, there is no local electric bus manufacturer, and, hence, such buses have to be imported. Table 5.2 shows the list of current BE bus vendors in the Indian market. The approximate market prices of BE bus models are also given in the table. The cost of BE buses can also be tuned by customizing the bus models according to the drive cycle and application requirements.

Table 5.2 List of models and vendors available in India

Vendor	Model	Price (INR)
BYD	K9	2.7 crores
Optare	Versa	2–3 crores

5.5. Charging Infrastructure for BE Buses

Presently, the BE bus penetration of the market can be improved by increasing the drive range of the vehicles and the availability of sufficient charging stations. In order to successfully deploy a BEV fleet and the corresponding charging infrastructure, a transport company must take into account various factors such as peak electricity demand of the local region, duty cycles, drive cycles, terrain structure, garaging locations, and availability of on-site and off-site public charging stations. These factors can influence the decisions on the number, location and type of charging units. City planners, bus fleet managers and utilities need to collaborate to identify the strategic placement of the charging points. In recent years, charging infrastructure has grown in the Electric Vehicles Initiative (EVI) member countries. Norway, a leader in EV infrastructure development,

with a small population of 5 million, installed 4,500 charging stations, driving consumers to purchase over 18,000 plug-in cars in 2014 (DeMorro 2014). This shows that the availability of charging station boosts the acceptance of EV among consumers. The recent growth in EV-charging stations in the major cities of the world is shown in Table 5.3.

Table 5.3 Total number of charging stations (EVSE) in various cities

Cities	Year 2011	Recent Years (2013–2015)
Amsterdam	350	1,250
Barcelona	248	4,420
Berlin	220	1,400
Brabantstad	500	3,000
Hamburg	100	600
North east	400	1,000
Rotterdam	100	1,000
Shanghai	687	5,000

(Clean Energy Ministerial et al. 2012)

United States of America

California currently has about 6,000 charging stations. The majority of the current charging stations are owned by Tesla Motors in California, while Pacific Gas and Electric is planning to develop 25,000 EV-charging stations. The total capital expenditure is estimated to be USD 635.8 million. This utility company has designed this project to help the state achieve its mandate to reduce its emissions by 80% below the 1990s levels by 2050 (Wang 2015).

The Netherlands

Electricity grid operators in the Netherlands have come together to install the charging infrastructure for BEVs. They have formed a consortium called “E-laad Foundation”, which has planned to install 10,000 charging points in the public domain. The total cost of implementation of this charging infrastructure is estimated to be USD 28 million. These charging points will be installed in two ways: 2,000 charging points will be installed according to the municipal government’s application and 8,000 charging spots will be installed for common BEV consumers. E-laad uses the Dutch mobility plan as a guideline to support local BEV mobility (IA-HEV 2010).

Germany

Germany has high potential for EV adoption. In 2014, Germany had a population of 80 million and recorded about 10,000 EVs running on roads. However, the country has only about 100 quick-service charging points for electric cars, allowing drivers to recharge batteries in less than an hour, and about 4,800 charging stations with normal charging capacity. Utility companies in Germany are collaborating with automobile manufacturers to develop more charging infrastructure at strategic locations (IA-HEV 2011). According to a report by the German Transport Ministry, the motorway operating firm Tank & Rast GmbH is planning to install quick-service charging stations at 400 selected sites by 2017 (Reuters 2014).

Standardization of EVSE

Standardization of charging infrastructure is another important step for integrating the entire BEV ecosystem. EVSE components will have a good supply chain in the market if a certain level of standardization of equipment is achieved. For instance, a standardized plug will ensure compatibility at charging stations for various models of BEVs. It will also reduce the overall cost of the charging infrastructure. The general nomenclature for a standard EVSE in European charging stations is given in Table 5.4.

Table 5.4 Charging standards for EVSE in Europe

	Plug Voltage	Range	Comments
AC Level 1	120 V plug	2–5 miles of range per hour of charging	One end of the cord is a NEMA 5-15 connector (3 pin). The other end of the plug is a J1772 standard connector
AC Level 2	240 V plug	10–20 miles of range per hour of charging	This charging option can operate at up to 80 A. This is a typical installation-at-home charging station. This can also be installed in public charging stations. The standard (SAE J3068) is under development for higher, faster charging at larger currents
DC Fast Charging:	208/480 V plug	50–70 miles of range per 20 min of charging	CHAdeMO or SAE DC fast-charge connectors: DC fast charging allows better application along heavy-traffic transits
Inductive Charging:	240 V plug	10–20 miles of range per hour of charging	Presently, this technology is used using AC Level-2 parameters

(Alternative Fuels Data Center: 2015)

5.6. Challenges for BE Buses

This section discusses the challenges in the implementation of BEV technology in India. These are mainly related to the supply chain, charging infrastructure, battery safety and cost of BE buses.

Supply chain: BE Bus and Components

The acceptance of any new product in the market depends upon the ease of availability of the product along with auxiliary components. Therefore, the development of a robust supply chain to sustain continuous production and consumption of the product is critical for its success. One of the major challenges for any new automotive technology manufacturer is to evolve a sustainable supply chain strategy keeping in mind the impact of this decision on the vehicle performance in a global operating environment. To develop and maintain a good supply chain, auto companies adopt such steps as setting up clear sales targets for the BEV before strategizing the supply chain, systematic flow of information between various departments of the company, robust supplier integration, continuous assessment of the product and the supply chain, updating the supply chain strategy according to the feedback from the market assessment (Puotunen 2013), etc.

The sales numbers of BEVs are very small compared with those of conventional fuel-based vehicles. Globally, very few manufacturers supply BEVs, which are limited to select few cities. Except BYD, all other BE bus manufacturers have comparatively small production numbers. Therefore, there is a lack of a well-established supply chain for vehicles and their components. This increases costs and also creates apprehension among customers about the standardization and availability of support equipment.

The Ministry of New and Renewable Energy (MNRE) had launched an incentive program in 2010 to promote EVs. It led to a remarkable increase in the sales of two-wheeler BEVs. But over the past two years, many two-wheeler BEV manufactures in India have shut down their businesses because of the receding demand (Mukherjee 2014). Current owners of these electric two-wheelers will have to find alternate sources to get replacement parts for their vehicles. In the four-wheeler BEV segment, the only manufacturer in India, Mahindra & Mahindra, is also facing the problem of low demand (Mukherjee 2014). In the case of the BE bus segment, only a few buses have been sold in India and none of them are produced domestically. The low-demand scenario is creating a negative impact on maintaining a good supply chain.

One of the proposed solutions for the supply chain issue of BE buses is to have long-term contracts with the suppliers to provide multiple vehicle units. This will ensure suppliers are available to service the vehicle in operation. In addition, warranty claims and parts for replacement can be seamlessly obtained from the manufacturers. For instance, municipal and state transport agencies can have long-term contracts with BE bus manufacturers that can demonstrate the feasibility of BE buses to private companies. Moreover, consumer organizations can consider procuring vehicles from well-established vendors with proven track records. This might incur some additional costs initially, but might save future expenses by reducing the failure rates of batteries and vehicles, and defaults on warranty claims and services.

Charging Infrastructure

Lack of charging infrastructure is a major impediment to India's BEV adoption. Lack of a continuous supply of good-quality power for charging is also a challenge for higher BEV penetration in the market. According to the NEMMP, the additional demand for electricity to charge all BEVs in India is expected to be about 1 GW by 2020 (Department of Heavy Industries, GoI 2012). India already has a peak electricity shortage of 3.7% (Press Trust of India 2014), with regular power outage a concern in many cities. Therefore, consumers are skeptical about buying BEVs. The government should now step in to cover the current deficit by establishing appropriate power management and additional generation infrastructure for BEV charging.

Important issues regarding the development of charging infrastructure to deploy BE buses in India are:

- Development of a continuous-power-supply roadmap by utilities and transport agencies
- Connections for normal and fast charging at bus depots and in public locations.

Currently, a few government public transit agencies like the Bengaluru Metropolitan Transport Corporation (BMTC) and the Himachal Pradesh Public Transport undertaking are trying to deploy BE buses. The advantage of government deployment is that they can have strategic tie-ups with utility companies to charge BE buses; e.g., the BMTC and the Bengaluru Electricity Supply Company Ltd. (BESCOM) can collaborate to have a continuous supply of power for BE bus charging at bus depots. It will not only ensure smooth operation of BE buses by the BMTC, but also the smooth functioning of load management at BESCOM. The second issue is the electricity connections. The rated capacity of the current electricity connection and load line, installed at bus depots, might not be compatible to set up EVSE. For example, simultaneous operation of multiple fast chargers will require a three-phase connection and high-tension-line installation. Therefore, the solution again is collaboration between the electricity supply (utility) companies and transit companies to establish EVSE in the depots and a strategic network of EVSE across the city.

Battery Issues: Safety

The batteries in BE vehicles are required to handle high power and to have high energy capacity under different operating conditions. The safety and performance of the battery should be given the highest priority in BE vehicles. The performance of the battery depends upon its operating conditions such as temperature, charging /discharging current, State of Charge (SoC), etc. On the other hand, factors that can affect the safety of a battery include mechanical abuse of the battery, overcharging and battery failures at extreme temperatures (Casey 2015). It is crucial to maintain a balance between the performance and safety of the batteries. The next subsection discusses some of the concerns regarding the safety of LIBs.

Battery Safety: Mechanical abuse

The vibrations and shocks sustained during the shipping of batteries or in the daily operation of BE buses may cause mechanical defects in the battery. These defects might also lead to short-circuits in the cells. Failures resulting from mechanical abuse are generally similar to high-temperature failures, which are explained later in this section under "Battery Safety: Effect of extreme temperatures". A strong chassis to hold the batteries and shock-absorbing materials around the battery packs can ensure vehicle safety.

Battery Safety: Overcharging

Overcharging means charging beyond the point of full SOC (100%), imparting a higher voltage to the cathode and, hence, the cell. The voltage values for various battery types are mentioned in Table 4.11. When an LIB is charged beyond the designated safe voltage window, it can lead to the plating of metallic lithium on the anode (graphite) and also to the generation of CO₂ at the cathode. The excess build-up of gas pressure eventually causes an explosion in the battery. Further, the extra energy supplied to the battery gets absorbed by the battery materials. After a certain safety level is crossed, the battery materials might decompose causing massive battery failure. The decomposition reaction releases energy that can cause a sudden rise in temperatures. LIBs use non-aqueous flammable electrolytes, which could burn due to high temperature, causing a fire hazard (Casey 2015). A BMS can control the overcharging issues by sending signals to the battery charger to start or stop the charging. It can open the safety valves and vents in case of an emergency. It should be noted that LIB is not the only battery that is prone to safety hazards during overcharging. Lead-acid and Ni-based batteries can also experience meltdown when overcharged above the designated voltage window and catch fire. The key is to manage the battery operations efficiently and with appropriate BMS protocol.

Battery Safety: Effect of extreme temperatures

The typical operating range for LIBs is -20°C to 60°C (McDowall, n.d.). However, the operating range for a charging cycle is 0°C – 45°C . It is advised by the manufacturers that the battery operate at 10°C – 30°C to attain a longer service life. In winters, challenges in battery function arise in places like Shimla where temperatures fall below 0°C (lowest -10°C) (Battery University 2015a). At low temperatures, the ionic conductivity of the electrolyte decreases, which limits the battery performance. In warmer places, where temperature rises above 40°C – 50°C , there is again a risk of battery failure. Charging of the battery at high temperatures is not advised as the charging operation increases the battery temperature further due to ohmic resistances. It can lead to damages to the battery and a reduction in the operating life. Therefore, the battery compartment should be well insulated in winters, and the temperature of the battery compartment should be maintained at moderate levels through active cooling–heating systems.

Battery Safety: Thermal runaway

Mechanical abuse, short-circuit and overcharging can increase the local temperatures inside the battery. At a high temperature (above 130°C), the SEI in the battery dissolves and lithium ions react with the electrolyte (Casey 2015). This reaction is exothermic and increases the temperature of the battery further. The higher temperature accelerates the reaction, which results in even higher temperatures, leading to the thermal degradation of the battery materials. This is called thermal runaway of the battery and can lead to a fire hazard; the process is presented in Figure 5.5. In 2006, Sony recalled about 535,000 laptops, which were under overheating and potential fire hazard (Golubkov et al. 2014). In 2013, a similar thermal runaway problem was observed in Boeing 787 Dreamliner flights, which resulted in the temporary disruption of the carrier operations (Paul 2010).

Figure 5.5 Process of thermal runaway in LIBs

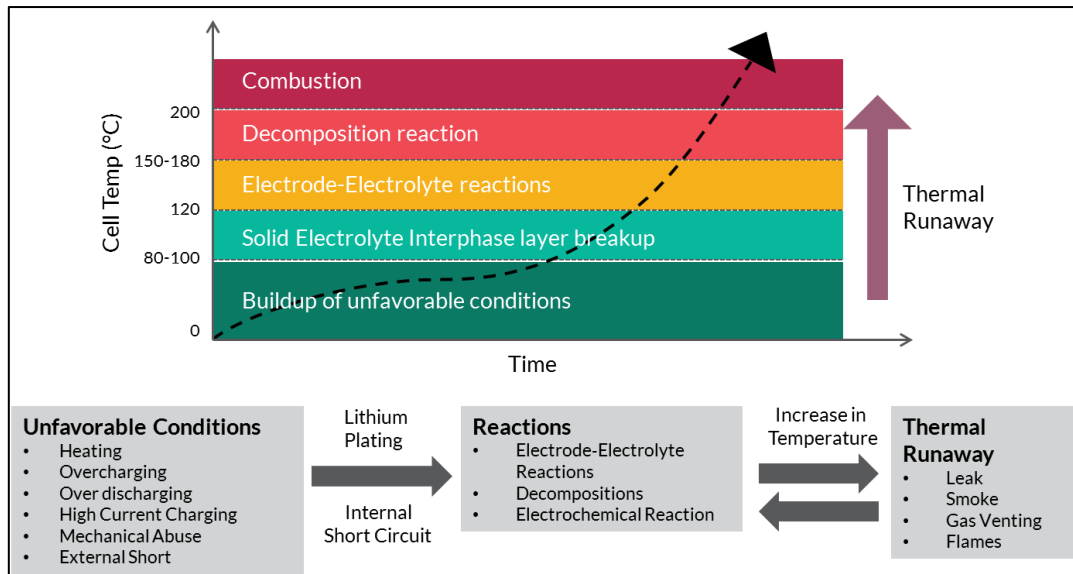

(Topham 2013)

In BE buses, the temperature of the battery compartment should be maintained to within the recommended temperatures levels (10°C–30°C). The BMS monitors the temperature levels in the battery, and it can control the operation of the battery according to the environment. In conclusion, the BMS reduces the chance of a battery failure and fire hazard considerably. Researchers are looking for alternative electrode materials and electrolytes that can provide a wider operating temperature range for the battery by broadening the tolerance window.

Cost of BE buses

High capital costs of BE buses are one of the major barriers in their mass adoption. BE buses can break even with respect to the diesel buses in 10–14 years given their low running costs (INR/km)(World Weather Online 2015). The reason for the high costs of BE buses is the battery cost, which is still higher than the target benchmark cost that has been determined in several studies of the battery industry. At the benchmark cost of the battery, the mass production and adoption of BEVs will be economically feasible. The prices of LIBs and the overall EV technology are slowly reducing. Another reason for the high costs of BE buses is that India does not have an indigenous manufacturing facility for BE buses. In future, domestic companies might be able to reduce costs by manufacturing buses locally. Intelligent planning and strategic implementation of buses and EVSE will reduce the costs further. Cheaper financing options by the government can also make the BEV market attractive.

6. References

- Advanced Vehicle Testing Activity. n.d. "How Do Gasoline & Electric Vehicles Compare?" Idaho National Laboratory. <http://avt.inel.gov/pdf/fsev/compare.pdf>.
- Albright, Greg, Jake Edie, and Said Al-Hallaj. 2012. "A Comparison of Lead Acid to Lithium-Ion in Stationary Storage Application." AllCell Technologies LLC. <http://www.batterypoweronline.com/main/wp-content/uploads/2012/07/Lead-acid-white-paper.pdf>.
- Alternative Fuels Data Center: 2015. "Developing Infrastructure to Charge Plug-In Electric Vehicles." *U.S. Department of Energy*. http://www.afdc.energy.gov/fuels/electricity_infrastructure.html.
- Andrea, David. 2010. *Battery Management Systems for Large Lithium Ion Battery Packs*. Artech House.
- Austin, Michael. 2013. "Consumer Perception Inhibits Electric Vehicle Adoption." *Electronic Design*, October 7. <http://electronicdesign.com/power/consumer-perception-inhibits-electric-vehicle-adoption>.
- Barnitt, R. 2008. "BAE/Orion Hybrid Electric Buses at New York City Transit." Technical Report NREL/TP-540-42217. National Renewable Energy Laboratory. <http://www.nrel.gov/docs/fy08osti/42217.pdf>.
- Barnitt, R., and K. Chandler. 2006. "New York City Transit (NYCT) Hybrid (125 Order) and CNG Transit Buses." Technical Report NREL/TP-540-4012. National Renewable Energy Laboratory. <http://www.nrel.gov/docs/fy07osti/40125.pdf>.
- Battery University. 2015a. "Charging at High and Low Temperatures." *Battery University*. Accessed September 14. http://batteryuniversity.com/learn/article/charging_at_high_and_low_temperatures.
- . 2015b. "How to Prolong Lithium-Based Batteries." *Battery University*. Accessed September 14. http://batteryuniversity.com/learn/article/how_to_prolong_lithium_based_batteries.
- Burwell, Melcolm, James Goss, and Mircea Popescu. 2013. "Performance/cost Comparison of Induction-Motor & Permanent-Magnet-Motor in a Hybrid Electric Car." International Copper Association. <http://www.coppermotor.com/wp-content/uploads/2013/08/Techno-Frontier-2013-MBurwell-ICA-EV-Traction-Motor-Comparison-v1.8-Eng1.pdf>.
- Business wire. 2014. "City of Dalian Places Order for 1,200 BYD Electric Buses." *Business Wire*. <http://www.businesswire.com/news/home/20140307005664/en/City-Dalian-Places-Order-1200-BYD-Electric#.VfaKI5dKa4>.
- . 2015. "Research and Markets: China Bus Industry Report, 2015-2018." *Business Wire*. August 17. <http://www.businesswire.com/news/home/20150817006352/en/Research-Markets-China-Bus-Industry-Report-2015-2018#.VfZu05dKa4>.
- Business Wire. 2015. "Global EV Charging Stations to Skyrocket by 2020, IHS Report Says | Business Wire." Accessed August 23. http://www.businesswire.com/news/home/20150528005122/en/Global-EV-Charging-Stations-Skyrocket-2020-IHS#.Vdnnj7Ud_6B.
- BYD Auto. 2015. "BYD Electric Bus Specification." *Electric Bus | BYD Auto*. August 24. <http://www.byd.com/na/auto/electricbus.html>.
- . 2015. "BYD Auto, Build Your Dreams!" Accessed September 14. <http://byd-auto.net/vehicles/k9/index.php>.
- "BYDAuto." 2015. Accessed November 28. <http://www.bydauto.com.cn/car-param-K9.html>.
- Casey, Tina. 2015. "Proterra Diesel-Killing Electric Bus Is Ready For Prime Time (CT Exclusive Interview)." *CleanTechnica*. <http://cleantechnica.com/2015/04/08/proterra-diesel-killing-electric-bus-ready-prime-time-ct-exclusive-interview/>.
- Chan, C.C., and K.T. Chau. 1997a. "An Overview of Power Electronics in Electric Vehicles." *IEEE Transactions On Industrial Electronics* 44 (1): 3–13.

- . 1997b. "An Overview of Power Electronics in Electric Vehicles." *IEEE Transactions On Industrial Electronics* 44 (1): 3–13.
- Chen, Jennifer. 2015. "Shenzhen Wuzhoulong Electric Bus Gets Burned due to Battery Explosion." *China Automotive Review*.
<http://www.chinaautoreview.com/pub/CARArticle.aspx?ID=12154>.
- Chernova, Yuliya. 2015. "Electric Bus Maker Proterra Rides On With \$55 Million." *WSJ D Tech*.
<http://blogs.wsj.com/venturecapital/2015/06/30/electric-bus-maker-proterra-rides-on-with-55-million/>.
- Clean Energy Ministerial, Electric Vehicles Initiative, and International Energy Agency. 2013. "Global EV Outlook - Understanding the Electric Vehicle Landscape to 2020."
https://www.iea.org/publications/freepublications/publication/GlobalEVOutlook_2013.pdf.
- Clean Energy Ministerial, Project get Readt, Electric Vehicle Initiative, Rocky Mountain Institute, Hybrid and Electric Vehicles, and c 40 cities. 2012. "EV City Casebook - Alook at the Global Electric Vehicle." AMSTERDAM BARCELONA BERLIN BRABANTSTAD GOTO ISLANDS, NAGASAKI HAMBURG HELSINKI KANAGAWA LOS ANGELES NEW YORK CITY NORTH EAST ENGLAND PORTLAND RESEARCH TRIANGLE, NC ROTTERDAM SHANGHAI STOCKHOLM.
http://www.cleanenergyministerial.org/Portals/2/pdfs/EV_City_Casebook_LR.pdf.
- Delucchi, Mark A. 2001. "An Analysis of the Retail and Lifecycle Cost of Battery-Powered Electric Vehicles." *ELSEVIER, Transportation Research Part D: Transport and Environment*, 6 (6): 371–404.
- DeMorro, Christopher. 2014. "More EV Charging Stations Coming To Germany." *Gas 2*.
<http://gas2.org/2014/12/30/ev-charging-stations-coming-germany/>.
- Department for Environment, Food & Rural Affairs - GOV.UK. 2014. "Environmental Noise: Valuing Impacts on Sleep Disturbance, Hypertension, Productivity and Quiet." PB 14227. United kingdom: United Kingdom Government.
https://www.gov.uk/government/uploads/system/uploads/attachment_data/file/380852/environmental-noise-valuing-impacts-PB14227.pdf.
- Department of Heavy Industries, Gol. 2012. "National Electric Mobility Mission Plan 2020." Policy document. India: Ministry of Heavy Industries and Public Enterprise.
<http://dhi.nic.in/writereaddata/Content/NEMMP2020.pdf>.
- . 2015. "Faster Adoption and Manufacturing of (Hybrid &) Electric Vehicles Scheme." Policy document. India: Ministry of Heavy Industries and Public Enterprise.
<http://dhi.nic.in/UserView/index?mid=2418>.
- Dirjish, Mat. 2012. "What's The Difference Between Brush DC And Brushless DC Motors?" *Electronic Design*. <http://electronicdesign.com/electromechanical/what-s-difference-between-brush-dc-and-brushless-dc-motors>.
- "Electric Vehicle Market Forecasts: Global Forecasts for Light Duty Hybrid, Plug-In Hybrid, and Battery Electric Vehicle Sales and Vehicles in Use: 2014-2023." 2014. Navigant Research.
<https://www.navigantresearch.com/research/electric-vehicle-market-forecasts>.
- Electric Vehicles Initiative, and International Energy Agency. 2015. "Global EV Outlook 2015."
http://www.iea.org/evi/Global-EV-Outlook-2015-Update_2page.pdf.
- Electricity Supply Company Ltd. 2014. "Electricity Tariff - 2015." Annexure. Bangalore: Karnataka Electricity Regulatory Commission. <http://bescom.org/wp-content/uploads/2015/04/TO-BESCOM-2014.205-2442.pdf>.
- Eliis, Brian, and et al. 2010. "Positive Electrode Materials for Li-Ion and Li-Batteries." *Chemistry of Materials* 22 (3).
- Enhua, Liao. 2011. "Neural Network Based SOC Estimation Algorithm of LiFePO4 Battery in EV." University of Electronic Science and Technology of China.
- Environment and Energy Study Institute. 2001. "Hybrid Buses Costs and Benefits."
http://www.eesi.org/files/eesi_hybrid_bus_032007.pdf.

- Ernst and Young. n.d. "India's Energy Security: Key Issues Impacting the Indian Oil and Gas Sector." India: FICCI.
[http://www.ey.com/Publication/vwLUAssets/Indias_energy_security/\\$FILE/Indias_energy_security.pdf](http://www.ey.com/Publication/vwLUAssets/Indias_energy_security/$FILE/Indias_energy_security.pdf).
- Evans, Natalie, Simon Clement, Franzis Wimmer, and Venn Chesterton. 2014. "Clean Buses – Experiences with Fuel and Technology Options." Clean Fleet. http://www.clean-fleets.eu/fileadmin/files/Clean_Buses_-_Experiences_with_Fuel_and_Technology_Options_2.1.pdf.
- Gartner Inc. 2015. "Hype Cycle Research Methodology." *Gartner Inc.*
<http://www.gartner.com/technology/research/methodologies/hype-cycle.jsp>.
- Global Green Growth Institute. 2014. "Green Growth Strategy for Karnataka." Case Studies.
http://gggi.org/wp-content/uploads/2014/12/Karnataka-GG-Case-Studies_FINAL_Web-Version.pdf.
- "Global Market Study on Electric Bus: Asia Pacific to Witness Highest Growth by 2020." 2015. Persistence Market Research.
- Golubkov, Andrey W., David Fuchs, Julian Wagner, Helmar Wiltsche, Christoph Stangl, Gisela Fauler, Gernot Voitic, Alexander Thaler, and Viktor Hacker. 2014. "Thermal-Runaway Experiments on Consumer Li-Ion Batteries with Metal-Oxide and Olivin-Type Cathodes." *RSC Adv.* 4 (7): 3633–42. doi:10.1039/C3RA45748F.
- Gordon-Bloomfield, Nikki. 2015. "U.S. EPA Sets Gas Mileage Standards: 54.5 MPG By 2025." *Green Car Reports*. Accessed August 18. http://www.greencarreports.com/news/1078795_u-s-epa-gives-final-ruling-on-gas-mileage-standards54-5mpg-by-2025.
- Government of India. 2014. "Auto Fuel Vision and Policy 2025." Report of the Expert Committee. India. <http://petroleum.nic.in/docs/autopol.pdf>.
- Greater London Authority. 2015. "Pure Electric Double-Decker London Bus Trial Announced at World-First Clean Bus Summit." *London.gov.uk*. Accessed September 14.
<https://www.london.gov.uk/media/mayor-press-releases/2015/06/pure-electric-double-decker-london-bus-trial-announced-at-world>.
- Greenstone, Michael, Janhavi Nilekani, Rohini Pande, Nicholas Ryan, Anant Sudarshan, and Anish Sugathan. 2015. "Lower Pollution, Longer Lives, Life Expectancy Gains If India Reduced Particulate Matter Pollution." *Economic & Political Weekly*.
- "Guidance for Implementation of Electric Vehicle Charging Infrastructure." 2010. Transport for London. [http://app.thco.co.uk/WLA/wt.nsf/Files/WTA-3/\\$FILE/EVCP-guidance-version-1-Apr10%5B1%5D.pdf](http://app.thco.co.uk/WLA/wt.nsf/Files/WTA-3/$FILE/EVCP-guidance-version-1-Apr10%5B1%5D.pdf).
- Hadley, Stanton, and Tsvetkova Alexandra. 2008. "Potential Impacts of Plug-in Hybrid Electric Vehicles on Regional Power Generation." Oak Ridge, Tennessee 37831: OAK RIDGE NATIONAL LABORATORY. <http://aprs.ornl.gov/sci/ees/etsd/pes/pubs/Pub7922.pdf>.
- He, Amy. 2013. "BYD's Electric Bus on Big Apple's Streets." *ChinaDaily U.S.A.*
http://usa.chinadaily.com.cn/epaper/2013-09/18/content_16978814.htm.
- IA-HEV. 2010. "The Netherlands - Charging Infrastructure - The Netherlands." *Hybrid & Electric Vehicles*. <http://www.ieahev.org/by-country/the-netherlands-charging-infrastructure/>.
- . 2011. "Germany - Charging Infrastructure - Germany | IA-HEV." *Hybrid & Electric Vehicles*. <http://www.ieahev.org/by-country/germany-charging-infrastructure/>.
- IEA. 2012. "Energy Technology Perspectives 2012."
https://www.iea.org/publications/freepublications/publication/ETP2012_free.pdf.
- Indian Network for Climate Change Assessment. 2010. "India: Greenhouse Gas Emissions 2007." Ministry of Environment and Forest, Gol. http://www.moef.nic.in/downloads/public-information/Report_INCCA.pdf.
- Inter Governmental Panel for Climate Change. 2006. "2006 IPCC Guidelines for National Greenhouse Gas Inventories: Chapter3 - Mobile Combustion." Volume 2: Energy. http://www.ipcc-nggip.iges.or.jp/public/2006gl/pdf/2_Volume2/V2_3_Ch3_Mobile_Combustion.pdf.

- International Energy Agency. 2010. "Energy Technology Perspective - Scenarios and Strategies to 2050." <https://www.iea.org/publications/freepublications/publication/etp2010.pdf>.
- . 2012. "Energy Technology Perspective 2012; Pathways to a Clean Energy System." https://www.iea.org/publications/freepublications/publication/ETP2012_free.pdf.
- . 2015. "Energy and Climate Change." <https://www.iea.org/publications/freepublications/publication/WEO2015SpecialReportonEnergyandClimateChange.pdf>.
- IRENA. 2015. "Battery Storage for Renewables." IRENA.
- IUT, and CSTEP. 2014. "Review of Urban Transport in India." Bangalore. <http://cstep.in/uploads/default/files/publications/stuff/0038b8f5daffde935c12f955c6ea994e.pdf>.
- Jaffe, S, and K.A. Adamson. 2014. *Beyond Lithium Ion, Next- Generation Battery Technologies*. Beyond Lithium Ion, Next- Generation Battery Technologies.
- Kane, Mark. 2015. "BYD Scores Europe's Largest Electric Bus Fleet Order." *Inside Evs*. <http://insideevs.com/byd-scores-europes-largest-electric-bus-fleet-order/>.
- Kim, Lindsey. 2011. "Namsan Electric Bus Cruises into International Limelight." *CNN Travel*. <http://travel.cnn.com/seoul/life/namsan-electric-bus-cruises-limelight-262862>.
- Lajunen, Antti. 2015. "Evaluation of Electric Buses." Alto University. http://www.ecv.fi/@Bin/211333/ECV-seminariesitys_10-3-2015_Evaluation-of-EBuses_Antti-Lajunen.pdf.
- Leung, Alison, and Fang Yan. 2010. "BYD Sees Sizeable New Energy Car Profit from 2015." *Reuters*. <http://mobile.reuters.com/article/idUSTRE6BJ1SW20101220?irpc=932>.
- Linden, David, and Thomas Reddy. 2002. *Handbook of Batteries*. McGraw-Hill.
- Loveday, Eric. 2015. "BYD Electric Bus Sales - 4,000 Per Year In China." *Inside Evs*. <http://insideevs.com/byd-electric-bus-sales-4000-per-year-china/>.
- McDowall, Jim. n.d. "A Guide to Lithium - Ion Battery Safety." Jacksonville: Saft America Inc.
- Ministry of Commerce and Industry, Department of Commerce- Economic Division. 2015. "India's Foreign Trade (Merchandise): August 2015." Press Release. <http://commerce.nic.in/tradestats/filedisplay.aspx?id=1>.
- Ministry of Petroleum & Natural Gas, GoI. 2015. "Price." *Petroleum Planning & Analysis Cell*. Accessed August 19. http://www.ppac.org.in/content/149_1_PricesPetroleum.aspx.
- Ministry of Power, GoI. 2015. "Energy Efficiency." Ministry website. Accessed August 18. <http://powermin.nic.in/Energy-Efficiency>.
- Ministry of Road Transport and Highways. 2012a. "Road Accidents in India."
- . 2012b. "Road Transport Year Book, 2012."
- MIT Electric Vehicle Team. 2008. "Electric Powertrains." MIT. http://web.mit.edu/evt/summary_powertrains.pdf.
- M.J. Bradley & Associates LLC. n.d. "Comparison of Modern CNG, Diesel and Diesel Hybrid-Electric Transit Buses: Efficiency & Environmental Performance." <http://mjbradley.com/sites/default/files/CNG%20Diesel%20Hybrid%20Comparison%20FINAL%2005nov13.pdf>.
- Mukherjee, Sharmistha. 2014. "How India's E-Vehicle Dream Crashed into the Subsidy Wall." *Business Standard*. http://www.business-standard.com/article/companies/how-india-s-e-vehicle-dream-crashed-into-the-subsidy-wall-114082600021_1.html.
- MyPetrolPrice.com. 2015. "Bengaluru Diesel Prices." August 23. <http://www.mypetrolprice.com/6/Diesel-price-in-Bengaluru>.
- Nazri, G, and G Pistoia. 2004. *Lithium Batteries: Science and Technology*. Kluwer Academic Publishers.
- Nils-Olof Nylund. n.d. "Vehicle Energy Efficiencies." http://www.iea.org/media/workshops/2013/egrdrmobility/nylund_vehicle_energy_efficiencies.pdf.

- Nizam, Basharat. 2013. "Inductive Charging Technique." *International Journal of Engineering Trends and Technology* 4 (4). <http://www.ijettjournal.org/volume-4/issue-4/IJETT-V4I4P311.pdf>.
- Noel, Lance, and Regina McCormack. 2014. "A Cost Benefit Analysis of a V2G-Capable Electric School Bus Compared to a Traditional Diesel School Bus." *Applied Energy*. <http://www.udel.edu/V2G/resources/V2G-Cost-Benefit-Analysis-Noel-McCormack-Applied-Energy-As-Accepted.pdf>.
- Nykvist, Björn, and Mans Nilsson. 2015. "Rapidly Falling Costs of Battery Packs for Electric Vehicles." *Nature Climate Change* 5 (4): 329–32. doi:10.1038/nclimate2564.
- Pan, Jiahua, Haibing MA, and Ying Zhang. 2011. "Green Economy and Green Jobs in China: Current Status and Potential for 2920." Report 185. China: World watch Institute. [www.worldwatch.org/system/files/185 Green China.pdf](http://www.worldwatch.org/system/files/185%20Green%20China.pdf).
- Parkinson, Giles. 2014a. "How Battery Costs May Drop Below \$100/kWh." *CleanTechnica*. <http://cleantechnica.com/2014/10/13/battery-costs-may-drop-100kwh/>.
- . 2014b. "How Battery Storage Costs Could Plunge below \$100/kWh." *Renew Economy*. <http://reneweconomy.com.au/2014/battery-storage-costs-plunge-below100kwh-19365>.
- Paul, Ian. 2010. "Sony Vaio Laptop Recall: Everything You Need To Know." *TechHive*. http://www.techhive.com/article/200256/Sony_Vaio_Laptop_Recall_Everything_You_Need_To_Know.html.
- PR Newswire. 2012. "China to Emerge as the World's Largest Market for Green Energy Transit Buses, Projects Frost & Sullivan." *PR Newswire*. <http://www.prnewswire.com/news-releases/china-to-emerge-as-the-worlds-largest-market-for-green-energy-transit-buses-projects-frost--sullivan-181477141.html>.
- . 2015. "BYD and ADL Partner to Supply Go-Ahead London with Capital's First, Large-Scale Pure Electric Bus Fleet." *PR Newswire*. <http://www.prnewswire.com/news-releases/byd-and-adl-partner-to-supply-go-ahead-london-with-capitals-first-large-scale-pure-electric-bus-fleet-300121070.html>.
- Press Trust of India. 2014. "Peak Power Deficit Declined to 3.7% in November: CEA." *Business Standard*. http://www.business-standard.com/article/pti-stories/peak-power-deficit-lowers-slightly-to-3-7-in-nov-cea-114122500571_1.html.
- Proterra. 2015. "Press Releases." <http://www.proterra.com/category/press-releases/>.
- Puotunen, Emma. 2013. "IMPACT OF NEW PRODUCT DEVELOPMENT DECISIONS ON SUPPLY CHAIN." Master of Science Thesis. Tampere University of Technology. <https://dspace.cc.tut.fi/dpub/bitstream/handle/123456789/21413/Puotunen.pdf?sequence=3>.
- PV magazine. 2014. "BYD Unveils Two Electric Buses with Vast Battery Capacity." *PV Magazine*. http://www.pv-magazine.com/news/details/beitrag/byd-unveils-two-electric-buses-with-vast-battery-capacity_100016811/.
- Reuters. 2014. "Germany Plans Electric Car Motorway Charging Stations - Document." *Reuters*. <http://www.reuters.com/article/2014/12/27/germany-electric-cars-idUSL6NOUB0AJ20141227>.
- Rippel, Wally. 2007. "Induction Versus DC Brushless Motors." *Tesla Blog*. <http://www.teslamotors.com/blog/induction-versus-dc-brushless-motors>.
- "Roadster Technology." 2015. *Motor | Tesla Motors*. <http://my.teslamotors.com/roadster/technology/motor>.
- Rose, Jason C, and Michael A Staiano. 2007. "A Comparison of Green and Conventional Diesel Bus Noise Levels." In . Reno, Nevada. http://staianoengineering.com/images/NC07_Ross_Staiano_-_A_comparison_of_green_and_conv.pdf.
- "SAE J1772 - Wikiwand." 2015. Accessed August 23. http://www.wikiwand.com/en/SAE_J1772.

- Saft. 2014. "Lithium Battery Life; Solar Photovoltaic (PV) - Energy Storage Systems (Ess)." Saft. http://www.saftbatteries.com/force_download/li_ion_battery_life__TechnicalSheet_en_0514_Protected.pdf.
- Science, Neil Bowdler, Technology Reporter, and B. B. C. News. 2015. "Wirelessly Charged Electric Buses Set for Milton Keynes." *BBC News*. August 23. <http://www.bbc.com/news/technology-25621426>.
- . 2015. "Wirelessly Charged Electric Buses Set for Milton Keynes." *BBC News*. Accessed August 23. <http://www.bbc.com/news/technology-25621426>.
- Shamah, David. 2012. "Electric Bus Fleet Heads to Tel Aviv." *The Times of Israel*. <http://www.timesofisrael.com/tel-aviv-to-get-electric-bus-fleet/>.
- Sustainable Development Department, World Bank. 2013a. "India Diagnostic Assessment of Select Environmental Challenges." 70004-IN. India. http://www-wds.worldbank.org/external/default/WDSContentServer/WDSP/IB/2013/07/16/000442464_20130716091943/Rendered/PDF/700040v10ESW0P0box0374379B00PUBLIC0.pdf.
- . 2013b. "India Diagnostic Assessment of Select Environmental Challenges." 70004-IN. India. http://www-wds.worldbank.org/external/default/WDSContentServer/WDSP/IB/2013/07/16/000442464_20130716091943/Rendered/PDF/700040v10ESW0P0box0374379B00PUBLIC0.pdf.
- Sustainable Urban Transport Project. n.d. "Avoid-Shift-Improve (A-S-I)." GIZ. : www.transport2020.org/file/asi-factsheet-eng.pdf.
- "Tata LPO 1613 CNG (Bus/CHS), ₹ 16,09,000." 2015. Accessed August 24. <http://www.truckaurbus.com/new-cv/tata/1613/tata-lpo-1613-cng-bus-chs-8377-16-09-000-1074.html>.
- TATA Motors. n.d. "Tata LPO 1512 Specification Sheet." <http://www.buses.tatamotors.com/download/images/Tata-TN-1512.pdf>.
- "Tata Starbus LE CNG 18, ₹ 30,17,000." 2015. Accessed November 28. <http://www.truckaurbus.com/new-cv/tata/le-slf/tata-starbus-le-cng-18-8377-30-17-000-558.html>.
- "Tata Starbus SLF 44." 2015. Accessed November 28. <http://www.truckaurbus.com/new-cv/tata/le-slf/tata-starbus-slf-44-8377-28-40-000-557.html>.
- Topham, Gwyn. 2013. "Heathrow Fire on Boeing Dreamliner 'Started in Battery Component.'" *The Guardian*, sec. World news. <http://www.theguardian.com/world/2013/jul/18/heathrow-fire-boeing-dreamliner-battery>.
- Truckaurbus.com. 2015. "Tata Starbus 32 AC (BS4), ₹ 20,19,000." August 23. <http://www.truckaurbus.com/new-cv/tata/starbus/tata-starbus-32-ac-bs4-8377-20-19-000-11232.html>.
- UNECE. n.d. "Technical Specification of Battery Management System for Electric Vehicles, QC/T 897-2011." <http://www.unece.org/fileadmin/DAM/trans/doc/2012/wp29grsp/EVS-1-08.pdf>.
- Urban Foresight, International Energy Agency, Electric Vehicle Initiative, and Clean Energy Ministerial. 2014. "EV City Casebook - 50 Big Ideas Shaping the Future of Electric Mobility." http://www.cleanenergyministerial.org/Portals/2/pdfs/EVI_2014_EV-City-Casebook.pdf.
- U.S. Department of Energy. 2001. "Diesel Hybrid Electric Buses." http://www.afdc.energy.gov/pdfs/diesel_hybrid.pdf.
- . n.d. "New York City Transit Diesel Hybrid-Electric Buses: Final Results." New York. <http://www.nrel.gov/docs/fy02osti/32427.pdf>.
- Verheijen, Edwin, and Jan Jabben. 2010. "Effect of Electric Cars on Traffic Noise and Safety." RIVM letter report 680300009. Netherlands: National Institute for Public Health and the Environment. <http://www.rivm.nl/bibliotheek/rapporten/680300009.pdf>.
- "Volvo 8400 LF, ₹ 71,84,000." 2015. Accessed November 28. <http://www.truckaurbus.com/new-cv/volvo-trucks-buses/8400/volvo-8400-lf-8377-71-84-000-613.html>.

- Wang, Uclia. 2015. "California Utility Aims To Quadruple The State's EV Charging Stations." *Forbes*. <http://www.forbes.com/sites/uciliawang/2015/02/09/california-utility-aims-to-quadruple-the-states-ev-charging-stations/>.
- Wikipedia. 2015. "Electric Bus." *Wikipedia, the Free Encyclopaedia*. https://en.wikipedia.org/w/index.php?title=Electric_bus&oldid=676916880.
- World Bank. 2013. "India: Diagnostic Assessment of Select Environmental Challenges. An Analysis of Physical and Monetary Losses of Environmental Health and Natural Resources." 70004-IN. The World Bank. http://www-wds.worldbank.org/external/default/WDSContentServer/WDSP/IB/2013/07/16/000442464_20130716091943/Rendered/PDF/700040v10ESW0P0box0374379B00PUBLIC0.pdf.
- World Health Organisation, and European Centre for Environment and Health. 2004. "WHO Technical Meeting on Sleep and Health." Bonn, Germany. http://www.euro.who.int/__data/assets/pdf_file/0008/114101/E84683.pdf.
- World Weather Online. 2015. "Bangalore, India Weather Averages | Monthly Average High and Low Temperature | Average Precipitation and Rainfall Days | World Weather Online." *World Weather Online*. <http://www.worldweatheronline.com/Bangalore-weather-averages/Karnataka/IN.aspx>.
- Wroclaw University of Technology. 2011. "Hybrid Electrical Vehicles."
- Yoney, Domenick. 2009. "Proterra Touring California with Fast-Charging Electric Bus." *Auto blog*. <http://www.autoblog.com/2009/02/08/proterra-touring-california-with-fast-charging-electric-bus/>.
- Young, Angelo. 2015. "New York City Scrapping Nearly A Fourth Of Its Hybrid Bus Engines For 100% Diesel Bus Engines." *International Business Times*. <http://www.ibtimes.com/new-york-city-scrapping-nearly-fourth-its-hybrid-bus-engines-100-diesel-bus-engines-1329977>.

